



Standard Test Method for Grease Particle Capture Efficiency of Commercial Kitchen Filters and Extractors¹

This standard is issued under the fixed designation F2519; the number immediately following the designation indicates the year of original adoption or, in the case of revision, the year of last revision. A number in parentheses indicates the year of last reapproval. A superscript epsilon (ϵ) indicates an editorial change since the last revision or reapproval.

1. Scope

1.1 This test method can be used to determine the grease particle capture efficiency of components and systems used in commercial kitchens to capture grease effluent prior to entering the exhaust duct. The results can be used to select a filter system best suited to a particular application.

1.2 This test method is applicable to filter components and systems. The performance information is obtained for new or clean filters and does not include the performance of used or loaded filters.

1.3 The filter can be evaluated with respect to the following (where applicable):

1.3.1 Pressure drop as a function of airflow through the filter (10.3), and

1.3.2 Particulate capture efficiency by particle size (10.4).

1.4 The values stated in inch-pound units are to be regarded as standard. The values given in parentheses are for information only.

1.5 *This test method may involve hazardous materials, operations, and equipment. This standard does not purport to address all of the safety concerns, if any, associated with its use. It is the responsibility of the user of this standard to establish appropriate safety, health, and environmental practices and determine the applicability of regulatory limitations prior to use.*

1.6 *This international standard was developed in accordance with internationally recognized principles on standardization established in the Decision on Principles for the Development of International Standards, Guides and Recommendations issued by the World Trade Organization Technical Barriers to Trade (TBT) Committee.*

¹ This test method is under the jurisdiction of ASTM Committee F26 on Food Service Equipment and is the direct responsibility of Subcommittee F26.07 on Commercial Kitchen Ventilation.

Current edition approved Dec. 1, 2020. Published December 2020. Originally approved in 2005. Last previous edition approved in 2015 as F2519 – 05 (2015). DOI: 10.1520/F2519-05R20.

2. Referenced Documents

2.1 *ASHRAE Standard:*²

ANSI/ASHRAE Standard 52.2-1999, Method of Testing General Ventilation Air-Cleaning Devices for Removal Efficiency by Particle Size

2.2 *ISO Standard:*³

ISO Standard 3966, Measurement of Fluid Flow in Closed Conduits—Velocity Area Method Using Pitot Static Tubes

3. Terminology

3.1 *Definitions:*

3.1.1 *airflow rate, n*—volumetric flow rate of air that passes through a filter or a bank of filters.

3.1.2 *capture efficiency, n*—proportion of aerosol particles removed by a filter as a function of particle size, usually expressed as a percentage.

3.1.3 *cartridge filter, n*—removable extractor, a removable, integral component of listed exhaust hoods, which is typically constructed of stainless steel and containing a series of horizontal baffles designed to remove grease and drain it into a container.

3.1.4 *fixed extractor, n*—water-wash hood or linear slot hood, a fixed, integral component of listed exhaust hoods, which is typically constructed of stainless steel and containing a series of horizontal baffles that run the full length of the hood.

3.1.5 *grease filter, n*—device installed into a hood to capture grease effluent before it enters the exhaust duct. Several identical devices may be installed in parallel in a hood. The device may consist of more than one component or section.

3.1.6 *pressure drop, n*—change in static pressure between the front surface of the grease filter and its rear surface under the rated airflow rate conditions.

² Available from American Society of Heating, Refrigerating, and Air-Conditioning Engineers, Inc. (ASHRAE), 1791 Tullie Circle, NE, Atlanta, GA 30329.

³ Available from International Organization for Standardization (ISO), 1 rue de Varembe, Case postale 56, CH-1211, Geneva 20, Switzerland.

3.1.7 *reference hood, n*—Type I exhaust hood used for the “no extractors” condition when measuring the efficiency and pressure drop of fixed extractor hoods. This is typically the same hood that is used for testing removable grease filters and removable cartridge filters.

3.2 Symbols:

E	= capture efficiency
n	= number of sample sets
P	= penetration
t	= t distribution variable
T	= sampling time
W	= counts of each size range (or channel) with test device(s) installed
WO	= counts of each size range (or channel) without test device(s)
δ	= standard deviation of a sample

3.3 Subscripts:

b	= background
c	= correlation
e	= estimated
i	= sample number
lcl	= lower confidence limit
n	= number of sample sets
o	= observed
t	= testing a filter
ucl	= upper confidence limit
w	= with test device(s) installed
wo	= without test device(s) installed

4. Summary of Test Method

4.1 There are three predominant classes of filters in kitchen ventilation grease extraction systems: removable baffle filters, removable cartridge filters, and fixed extractors.

4.2 Removable baffle and cartridge filters to be tested are installed into the test system.

4.2.1 Identical filters to be tested are installed into a standard 4-ft canopy hood connected to a nominal 12-in. round duct exhaust system. The filters should fit tightly together and into the opening and any bypasses larger than 1/8-in. wide on the ends are sealed.

4.2.2 For fixed-extractor systems, a reference hood shall be used for testing conditions that call for no filters to be installed in the hood. Testing requires switching between the reference hood and the fixed extractor hood.

4.2.3 A filter system to be used in a non-standard canopy hood is installed at the height of actual application above the floor and connected to a nominal 12-in. round duct exhaust system.

4.2.4 The static pressure drop across the filters is recorded at the test airflow.

4.2.4.1 For removable baffle or cartridge filters, the net filter pressure drop is determined by subtracting the pressure drop of the hood when the filters are removed from the pressure drop

measured when the filters are installed. The total exhaust volumetric flow rate must be equal in both pressure drop measurements.

4.2.4.2 For fixed-extractor hood systems, the pressure drop is determined by subtracting the pressure drop of the reference hood when the filters are removed from the pressure drop measured on the fixed-extractor hood. The total exhaust volumetric flow rate must be equal in both pressure drop measurements.

4.3 The total airflow rate through the exhaust system is set so that the volumetric flow rate through the filter under test is equivalent 250 cfm per linear foot (width) of filter (based on external filter dimensions).

4.3.1 Performance may also be evaluated at other airflows in accordance with manufacturer recommendations (see [Appendix X1](#)).

4.4 Balanced makeup air shall be provided at $75 \pm 5^\circ\text{F}$ and $50 \pm 20\% \text{ RH}$.

4.5 Particulate capture efficiency for removable grease filter or removable cartridges is determined by comparing particle concentration versus size in the exhaust duct with and without the filters installed.

4.5.1 Particulate capture efficiency for hoods with fixed extractors is determined by comparing particle concentration as a function of particle size in the exhaust duct with the fixed extractor hood and the reference hood without the filters installed.

4.5.2 The test aerosol is oleic acid that covers a size range from 0.3 to 10 μm in diameter or as specified by the manufacturer. Efficiency shall be reported as zero from 0.3 μm to the lower limit of the test conditions. Particulate concentration measurements (as a function of particle size) are taken in the exhaust duct using an isokinetic sampling probe and an optical particle counter. The particulate capture efficiency is determined by taking the difference between the particle concentration with and without the filters installed at each particle size range set on the particle counter.

5. Significance and Use

5.1 The pressure drop results can be added to the pressure drops of other components in an exhaust system to determine the total exhaust fan pressure requirement.

5.2 The particulate capture efficiency can be used with known particulate size emission data for a cooking appliance-food product combination to determine the total mass of grease particles captured by the filter, the total mass of grease particles that pass through the filter, and the particle size distribution of the grease particles that pass through the filter. [Fig. 1](#) shows an example particle capture efficiency curve.

6. Apparatus

6.1 *Mandatory and Discretionary Requirements*—Critical dimensions and arrangements of the test apparatus are shown in [Figs. 2-5](#). Vertical ductwork may also be used with the same critical dimensions (duct diameter, length, and so forth). All dimensions shown are mandatory unless otherwise indicated. Units shown are in inches unless otherwise indicated. The

**Particle Capture Efficiency (%)
versus Particle Size**

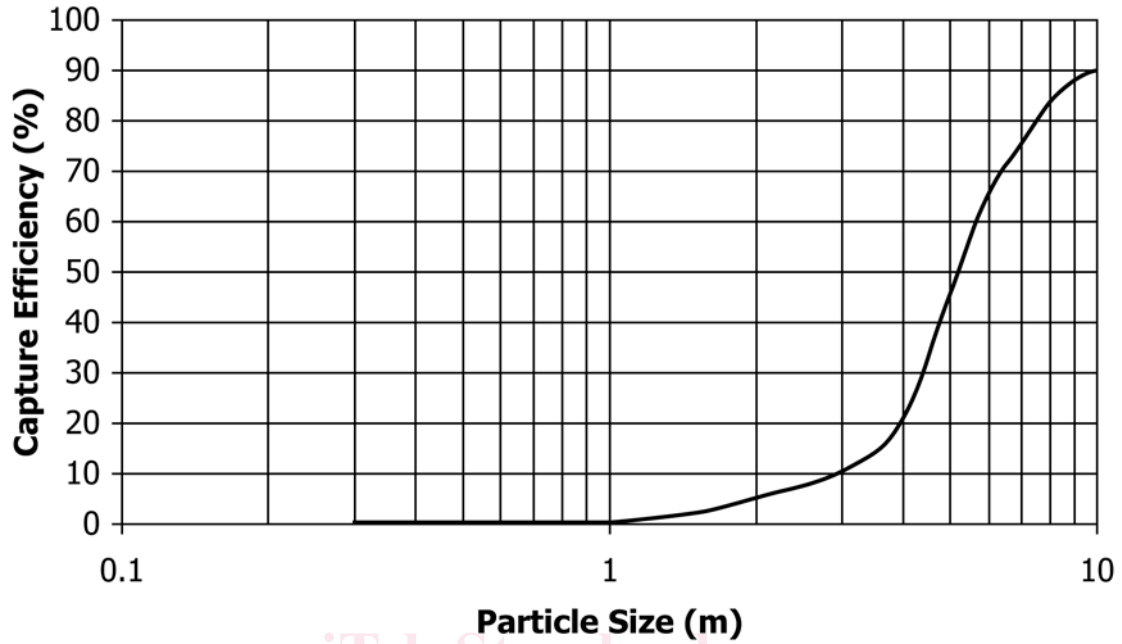

FIG. 1 Particle Capture Efficiency Example Curve

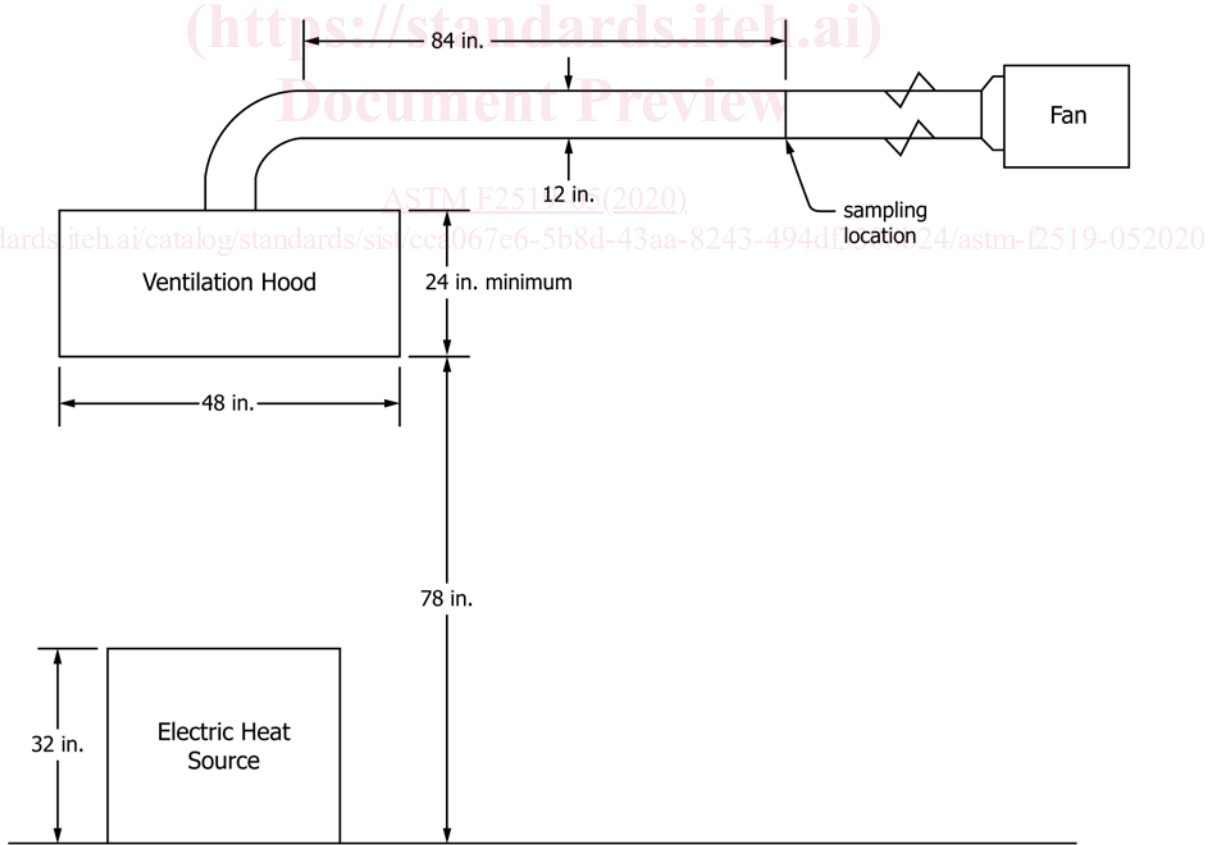

FIG. 2 Schematic Diagram of Test Apparatus—Front Elevation View of Horizontal Test Setup

design of equipment not specified, including but not limited to exhaust fan, makeup air system, and external structural

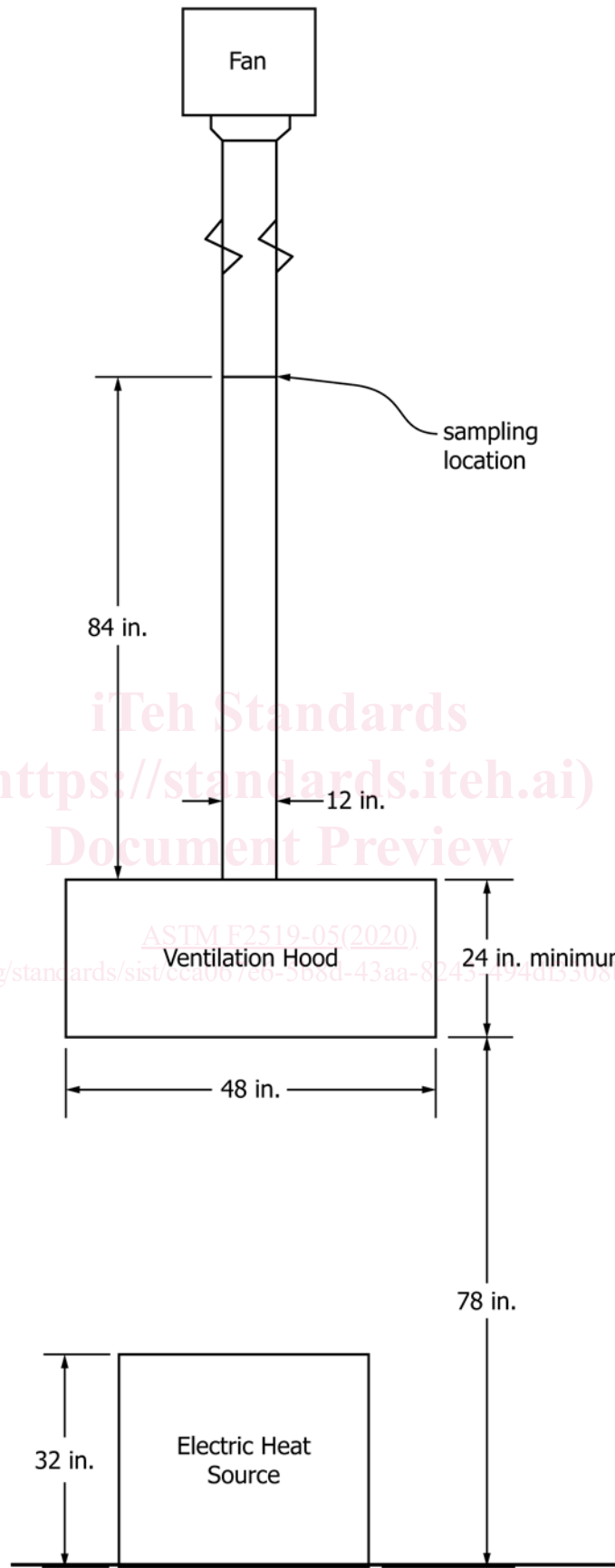

FIG. 3 Schematic Diagram of Test Apparatus—Front Elevation of Vertical Test Setup

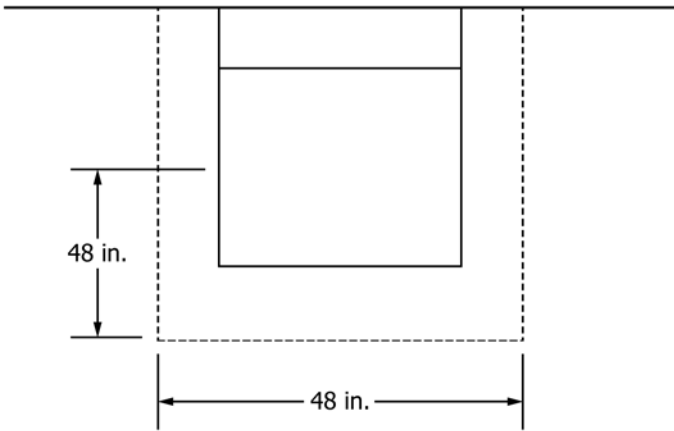

FIG. 4 Schematic Diagram of Test Apparatus—Plan View

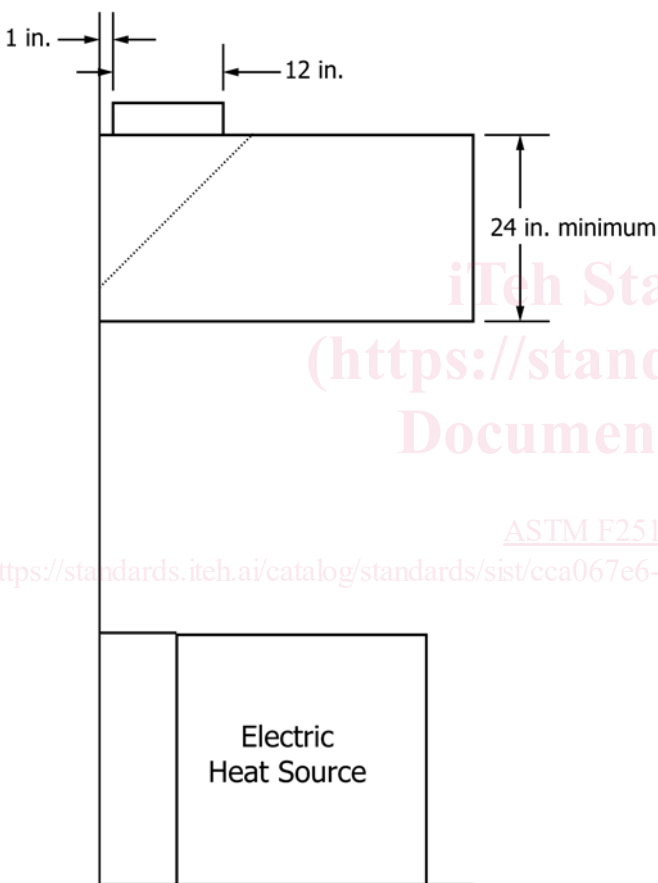

FIG. 5 Schematic Diagram of Test Apparatus—Side Elevation View

in the center of the hood with the rear surface of the opening 1.0 in. from the back side of the hood. If the hood is installed at a different height, a distance of 46 in. must be maintained between the appliance surface and bottom of the hood. The hood shall contain means for securing grease filters under test in a position typical in application.

6.2.1.2 Hoods with fixed extractors should be built to match the description given in 6.2.1.1 as closely as possible without affecting the hood's extraction efficiency.

6.2.1.3 The typical reference hood will be a canopy exhaust hood matching the one described in 6.2.1.1 and shown in Fig. 6. If the hood with fixed extractors cannot be built to match 6.2.1.1, then the reference hood shall be built to match the hood with fixed extractors.

6.2.1.4 To facilitate switching hoods, the lab may build rolling stands for each reference hood and the current hood being tested. These stands may be rolled in and out of the test rig. Care should be taken to insure that both hoods are installed in the same location at the same height (6½ ft) each time.

6.2.1.5 The test apparatus shown in Figs. 2-5 is designed for test filters with a nominal height of 20 in. It is permitted to test a bank of several filters in parallel if the width of an individual filtration device is less than 50 % of the width of the hood. Spacers may be added symmetrically on both ends of the filter under test if the filter does not span the entire width of the hood.

6.2.2 *Round Exhaust Duct*, 12 in. (0.305 m) in diameter, connected to the duct collar on the top of the exhaust hood and leading to an exhaust fan. All duct connections shall be sealed. The duct may be horizontal or vertical. If horizontal, it must have a 90-degree elbow configured as shown in Fig. 7. The elbow must have a centerline duct radius of 14-in.

NOTE 1—The r/D ratio is 1.167 for this configuration.

6.2.2.1 The distance from the duct collar for a vertical exhaust duct or from the end of the 90 degree elbow for a horizontal exhaust duct to the sampling location shall be 84 in. If a different sampling location is used, or a different exhaust configuration is used, an aerosol uniformity test shall be conducted.

6.2.2.2 The minimum distance from the sampling location to the nearest duct fitting or fan inlet shall be 24 in.

6.2.3 *Exhaust Fan*, capable of moving 1000 ft³/min (472 L/s) through the filters under test and the additional exhaust system components at the test static pressure condition. The fan shall have a variable frequency drive or other means to control the airflow rate. The exhaust shall be discharged outdoors.

6.2.4 *Makeup Air System*, a means for providing makeup air at 75 ± 5°F and 50 ± 20 % relative humidity to match exhaust rate without disturbing the airflow pattern near the exhaust hood.

6.2.5 *Heat Source*, a uniform electric heat source with a solid metal surface, a minimum 2 ft. deep by 3 ft. wide, maintained at an average surface temperature of 375 ± 5°F.

NOTE 2—A commercial electric griddle with a rated input between 7 and 10 kW and been shown to work well as a heat source.

supports, is discretionary, but the equipment must have adequate capacity to meet the requirements of this test method.

6.2 Test Facility:

6.2.1 Exhaust Hood:

6.2.1.1 The test installation should have a canopy exhaust hood which meets these requirements: 4 ft (1.2 m) in width and depth, minimum 2 ft (0.61 m) in height, wall mounted with the lower edge of the hood 6½ ft (2.0 m) from the floor and with a 12 in. (0.305 m) diameter round duct collar mounted on top

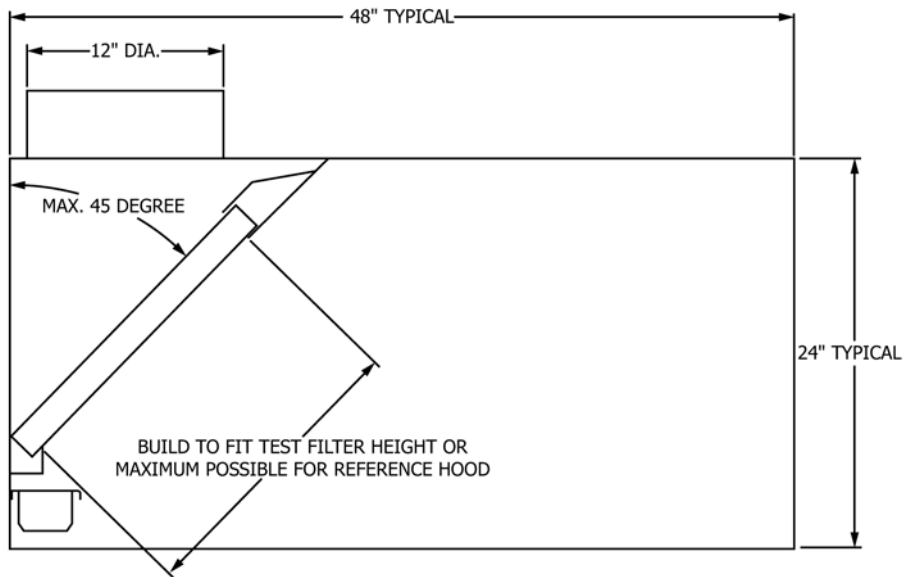

FIG. 6 Schematic Diagram of Reference Hood

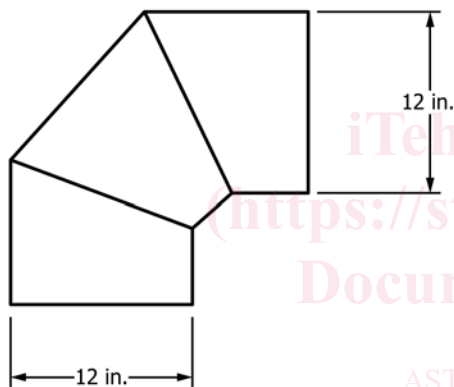

FIG. 7 Schematic Diagram of 90-Degree Elbow to Connect the Duct Collar on the Canopy Hood to a Horizontal 12 in. Diameter Round Exhaust Duct

6.2.5.1 The cooking surface of the heat source shall be 32 in. (0.81 m) above the floor. The heat source shall be centered under the hood from side to side and from front to back. Any air gap between the rear of the heat source and the back wall shall be sealed with a horizontal sheet of stainless steel positioned at the same height as the rear of the heat source.

6.3 Instrumentation:

6.3.1 *Flow Metering Station*, installed in the exhaust duct for measuring the airflow rate through the filters under test. Options include a grid of local velocity measurements using the log-Tchebycheff method, a flow nozzle, or an orifice plate. If a nozzle or orifice plate is used, it must be mounted downstream from the particle sampling location.

6.3.1.1 Airflow rate may be determined using velocity traverse measurements according to the log-Tchebycheff method (ISO Standard 3966). Local velocities shall be measured at the particle sampling location using a pitot tube, hot film anemometer, or hot wire anemometer. Velocity profiles shall be measured without filters installed in the hood and with test filters installed. Results shall be used to determine airflow

rate versus fan speed with and without filters installed to set the fan speed for proper airflow rate. The airflow and filter static pressure shall be continuously monitored.

6.3.1.2 Airflow rate may be determined by means of ASME long-radius flow nozzles with static taps. The dry bulb temperature, absolute pressure, and relative humidity of the exhaust airflow shall be measured in the duct immediately upstream of the flow-measuring device. These values shall be used for calculation of airflow rate. Measurements shall be made with and without the test filters installed to set the fan speed for proper airflow rate at each test condition.

6.3.2 *Barometer*, for measuring absolute pressure of the air entering the exhaust hood. The barometer shall have a resolution of 0.2 in. Hg (670 Pa).

6.3.3 *Differential Pressure Gage*, for measuring the pressure drop across the filters under test. The pressure gage shall have a range from 0 to 5 in. water (0 to 2.5 kPa), and have an accuracy of 1 % at full scale.

6.3.4 *Temperature Sensors*, industry standard Type T or K thermocouples, one mounted at the inlet to the particle sampling probe in the exhaust duct to measure the temperature of the exhaust, the other located 6½ ft from the floor and 6 ft in front of the center of the exhaust hood with radiation shielding to measure the dry bulb temperature of the makeup air.

6.3.5 *Humidity Sensor*, relative humidity sensor or dew point hygrometer to determine the relative humidity of the makeup air at a height of 6 ½ ft above the floor and 6 ft in front of the center of the exhaust hood.

6.4 Aerosol Generation System:

6.4.1 Other than the requirements of the following subsections, design features of the aerosol generator are discretionary. Refer to Appendix X2 for guidance.

6.4.2 The test aerosol shall be polydisperse liquid-phase oleic acid particles generated from a solution. The solution may be pure reagent grade oleic acid or a mixture of reagent grade oleic acid and isopropyl alcohol. The aerosol generator shall provide a stable test aerosol of sufficient concentration

over the diameter size range to meet the requirements of Section 12 without overloading the aerosol particle counter. See 8.4. The aerosol generator shall be designed to ensure that all alcohol is evaporated from the particles prior to being introduced into the test section.

6.4.3 After any alcohol evaporation necessary, the aerosol shall be brought to a Boltzman electrostatic charge distribution by a beta or gamma radiation generator with an activity of at least 185 MBq (5 mCi) or a corona discharge ionizer. The corona discharge ionizer shall have a minimum corona current of 3 μ A and shall be balanced to provide equal amounts of positive and negative ions.

6.4.4 The test aerosol shall be injected vertically upward at a point centered on the heated surface (front to back and side to side) and from 11 to 13 in. in height above the surface of the heat source. The injection system design is discretionary provided it fulfills the requirement.

6.5 Aerosol Sampling and Measurement System:

6.5.1 *Aerosol Sampling Probe*, for sampling particles in the exhaust duct. The probe shall be sharp edged and designed for isokinetic sampling at the given average duct velocity.

6.5.2 The design criterion for the sampling system shall be to provide a particle transport of >50 % for 10 μ m diameter oleic acid particles from the sampling probe inlet within the exhaust duct to the inlet of the particle counter.

6.5.3 *Diluters*, if used, shall provide equal dilution of both samples taken with and without the test filter installed in the hood. Dilution of just the sample without the filter installed is disallowed.

6.5.4 *Particle Counters*, permitted are optical counters (OPC) with wide-angle collection optics or other counters demonstrating good correlation in measuring particle size efficiencies, such as an aerodynamic particle counter (APC). An APC shall first be tested with oleic acid aerosol to establish the relationship between the aerodynamic particle size and the light-scattering particle size determined by an OPC. Calibrate the APC with polystyrene latex (PSL) spheres and use the relationship to express results as equivalent light-scattering size of oleic acid.

NOTE 3—Different instruments categorize particle size using different means. With an OPC, a beam of light is used to measure the geometric size of the particle, which is called the geometric mean diameter, d_g . An APC instrument measures the aerodynamic size of the particle, d_a . The relationship between these two is shown in Eq 1. Therefore, to convert the reported data from an APC to an OPC, Eq 2 shall be used. For oleic acid, the density is 1.117 gm/cm³.

$$d_a = d_g \cdot \sqrt{\rho} \quad (1)$$

where:

- d_a = aerodynamic particle size,
- d_g = geometric particle size, and
- ρ = density of the particle.

$$d_g = \frac{d_a}{\sqrt{\rho}} \quad (2)$$

6.5.4.1 The particle counter shall be capable of counting and sizing individual oleic acid particles in the particle diameter size range.

6.5.4.2 The particle counter shall measure the aerosol particles in its native particle size ranges and then the test aerosol particles shall be reported in 12 size ranges as shown in Table 1. The particle counter's correlation of measured response to physical particle size shall be monotonic for PSL particles from 0.30 to 10 μ m, such that only one size range shall be indicated for any measured response.

6.5.4.3 The particle counter shall be calibrated annually using known size PSL spheres.

6.5.4.4 The particle counter shall have less than 10 % coincidence loss at a particle counting rate of 300 000 particles/min and shall have a minimum inlet volume flow rate of 0.100 cfm. This flow rate shall not change more than 2 % with a 4.0 in. of water change in the pressure of the sampled air.

6.6 *Data Acquisition System(s)*, for monitoring and recording the surface temperature distribution on the griddle, the temperature and relative humidity of the makeup air, the temperature in the exhaust duct, and the particle concentration versus size in the exhaust duct, is discretionary.

7. Reagents and Materials

7.1 *Test Aerosol*—The test aerosol shall be liquid oleic acid particles generated from a solution. The oleic acid shall be reagent grade. The solution may consist of 100 % oleic acid. If necessary, reagent grade isopropyl alcohol may be used in the solution to assist the performance of the aerosol generator. The volume of isopropyl alcohol shall be based on the manufacturer's specification for the generator.

8. Preparation of Apparatus

8.1 Apparatus qualification tests shall verify quantitatively that the test rig and sampling procedures are capable of providing reliable pressure drop and particle size efficiency measurements. The tests shall be performed in accordance with Table 2.

8.1.1 Qualification tests shall be performed for:

- 8.1.1.1 Air velocity uniformity in the exhaust duct,
- 8.1.1.2 Aerosol concentration uniformity in the exhaust duct,
- 8.1.1.3 Aerosol concentration limit in the exhaust duct,
- 8.1.1.4 Aerosol generator response time,
- 8.1.1.5 Particle counter zero,
- 8.1.1.6 Particle counter sizing accuracy,

TABLE 1 Particle Counter Size Range Boundaries

Range	Lower Limit (μ m)	Upper Limit (μ m)	Geometric Mean Particle Size (μ m)
1	0.30	0.40	0.35
2	0.40	0.55	0.47
3	0.55	0.70	0.62
4	0.70	1.00	0.84
5	1.00	1.30	1.14
6	1.30	1.60	1.44
7	1.60	2.20	1.88
8	2.20	3.00	2.57
9	3.00	4.00	3.46
10	4.00	5.50	4.69
11	5.50	7.00	6.20
12	7.00	10.00	8.37

TABLE 2 Summary of System Qualification Measurement Requirements

Parameter	Requirement
Aerosol Uniformity: Based on traverse measurements over the 25-point grid at each test airflow rate	Coefficient of variation must be <15%
Upper Concentration Limit: Based on limiting the concentration to below the level corresponding to the onset of coincidence error	No predetermined level
Aerosol Generator Response Time	No predetermined level
Particle Counter Zero Count Check: Based on HEPA filter attached to the instrument's inlet	<10 counts per minute over the 0.3 to 10 μm range
Particle Counter Sizing Accuracy Check: Based on sampling of aerosolized monodispersed PSL spheres of known size	Relative maximum must appear in the appropriate sizing channel.
Aerosol Neutralizer Activity: Based on detection of radioactive source within neutralizer	Radioactivity must be detected.
Heat Source Surface Temperature: Based on thermocouples connected to the cooking surface	Average surface temperature must be 375 ± 5°F.

- 8.1.1.7 Radioactivity of the aerosol neutralizer, and
- 8.1.1.8 Electric heat source surface temperature.

8.2 Velocity Uniformity in the Exhaust Duct:

8.2.1 The uniformity of the air velocity in the exhaust duct at the sampling location shall be determined by three six-point traverses using the grid points shown in Fig. 8 and specified in Table 3, in the 12-in. diameter exhaust duct at vertical, and at 60 degrees clockwise and counter-clockwise from the vertical. The velocity measurements shall be made with an instrument having an accuracy of 10 % with approximately 10 fpm resolution. The uniformity test shall be performed at an airflow rate of 1000 cfm.

8.2.2 A one-minute average velocity shall be recorded at each grid point. The average must be based on at least ten readings taken at equal intervals during the 1-min period. The traverse shall then be repeated two more times to provide triplicate 1-min averages at each point for the given airflow rate. The average of the triplicate readings at each point shall be computed.

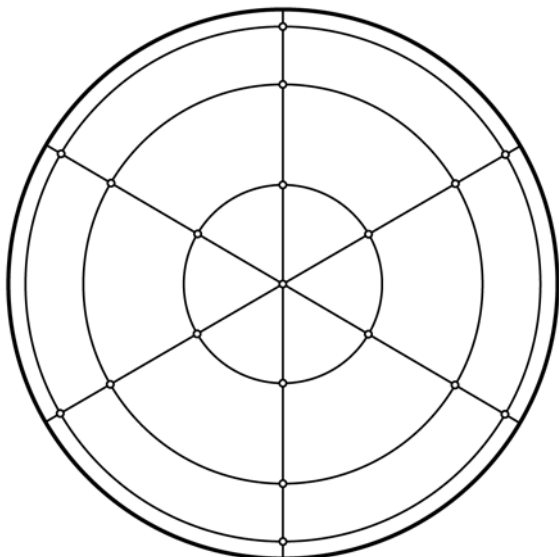

FIG. 8 Schematic of Velocity Measurement Locations Within the Exhaust Duct

TABLE 3 Position of Measurements According to log-Tchebycheff Rule for a 12-in. Duct

Sample Point	Distance from Side Wall Inlet Opening, in.
1	0.384
2	1.620
3	3.852
4	8.148
5	10.380
6	11.616

8.2.3 The CV (where CV is the coefficient of variation computed as the standard deviation/mean) of the nineteen corresponding grid point air velocity values shall be less than 10 %.

8.3 Aerosol Concentration Uniformity in the Exhaust Duct:

8.3.1 The uniformity of the aerosol concentration in the exhaust duct at the sampling location shall be determined by a twenty six-point traverse using the grid points shown in Fig. 9 and specified in Table 4 in the 12-in. diameter exhaust duct. The inlet nozzle of the sample probe shall be sharp edged and of appropriate entrance diameter to maintain isokinetic sampling within 10 % at the test airflow. The uniformity test shall be performed at an airflow rate of 1000 cfm.

8.3.2 The oleic acid aerosol shall be provided by the aerosol generator specified in 6.4 and the aerosol shall be injected vertically upward from a point 12 in. (± 1 in.) above the center of the griddle. The aerosol sampling probe shall remain stationary in its normal center-of-duct sampling location.

8.3.3 The aerosol concentration measurements shall be made with a particle counter meeting the specifications of 6.5.4. A one-minute sample shall be taken at each grid point with the aerosol generator operating. After sampling all 26 points, the traverse shall be repeated four more times to provide a total of five samples at each point. The five values at each point shall be averaged for each of the particle counter size ranges.

8.3.4 The CV of the corresponding 26 grid point particle concentrations shall be less than 15 % in each of the particle counter size ranges.

8.4 Concentration Limit in the Exhaust Duct:

Duct Cross-Section at Aerosol Sampling Locations

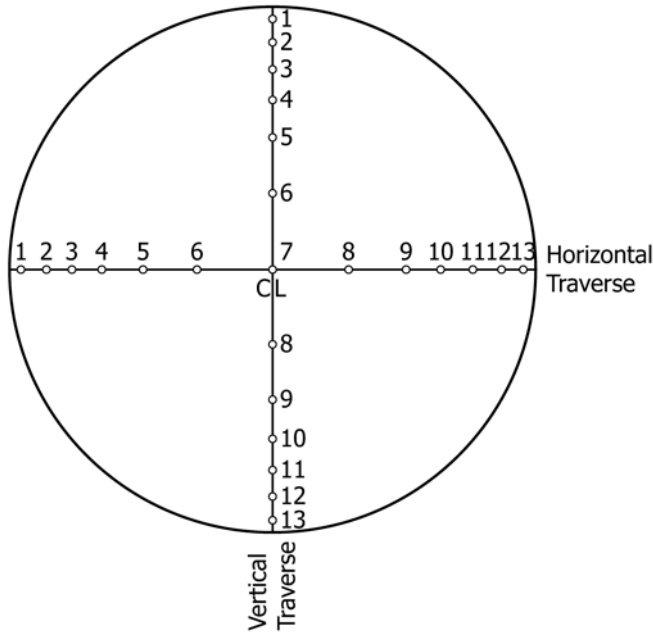

FIG. 9 Schematic of Particle Concentration Measurement Locations Within the Exhaust Duct

TABLE 4 Sample Point Locations for Duct Aerosol Spatial Uniformity Tests for a 12-in. Duct

Sample Points	Distance from Side Wall Inlet Opening, in.
1	0.252
2	0.804
3	1.416
4	2.124
5	3.000
6	4.272
7	6.000
8	7.728
9	9.000
10	9.876
11	10.584
12	11.196
13	11.748

8.4.1 A series of initial tests shall be performed over a range of challenge aerosol concentrations, with no filters installed, to determine a total concentration level for the particle size efficiency tests that does not overload the particle counter. The lowest total concentration level shall be less than 1 % of the instrument’s stated total concentration limit. The tests shall be performed with no filters installed in the hood and at an exhaust airflow rate of 1000 cfm.

8.4.2 The aerosol for these tests shall be generated using the same system and procedures as specified in 10.5.3 for the particle size efficiency tests.

8.5 *Aerosol Generator and Sampling System Response Time:*

8.5.1 Measure the time interval for the aerosol concentration to go from background level to steady test level after turning the aerosol generator on. The test shall be performed at

an airflow rate of 1000 cfm with the aerosol sampling probe inlet located at the center of the exhaust duct.

8.5.2 Measure the time interval for the aerosol concentration to return to the background level after turning off the generator. The exhaust flow rate shall be maintained at 1000 cfm.

8.5.3 These time intervals shall be used as the minimum waiting time between (1) activating the aerosol generator and beginning the particle counter sampling sequence, and (2) deactivating the aerosol generator and beginning the particle counter sampling sequence for determination of background aerosol concentrations.

8.6 *Particle Counter Zero:*

8.6.1 The zero count of the particle counter shall be verified to be <10 total counts per sample time, as determined in 12.5.2.2, used during testing in the 0.30 to 10 µm size range when operating with a HEPA filter attached directly to the instrument’s inlet.

8.7 *Particle Counter Sizing Accuracy:*

8.7.1 The sizing accuracy of the particle counter shall be checked by sampling aerosols containing monodispersed spheres of known size. Two sizes shall be used; one between 0.3 and 1 µm and the other between 1 and 10 µm. The particles may be solid polystyrene spheres or liquid drops of known composition. A relative maximum particle count shall appear in the particle counter sizing channel that encompasses the known diameter of the monodisperse aerosol.

8.8 *Confirmation of the Activity of the Aerosol Neutralizer:*

8.8.1 The activity of the radiation source within the aerosol neutralizer shall be confirmed by use of an appropriate radiation detection device. The measurement may be relative (as opposed to absolute) but shall be adequate to indicate the presence of an active source and shall be capable of being performed in a repeatable manner.

8.8.2 The measurement shall be repeated annually and compared to prior measurements to determine if a substantial decrease in activity has occurred. Replace neutralizers showing a lack of activity in accordance with the manufacturer’s recommendations.

8.9 *Electric Heat Source Temperature:*

8.9.1 The average surface temperature of the plate of the heat source shall be 375 ± 5°F.

8.10 *Summary of Qualification Test Requirements—*Qualification test criteria shall conform to Table 2.

8.11 *Apparatus Maintenance—*Maintenance items and schedules shall conform to Table 5.

9. **Preparation of the Test Sample(s)**

9.1 The filter device(s) to be tested shall be new (unused) and prepared in accordance with the manufacturer’s recommendations.

9.2 The number of identical devices to be tested simultaneously shall equal the number of devices that will span the width of the exhaust hood in the test facility.

9.3 Install the new, clean filter/device(s) for every series of tests. Installation shall be equivalent to a typical kitchen

TABLE 5 Summary of Apparatus Maintenance Schedule

Maintenance Item (Subsection Reference)	Incorporated Into Each Test	Bi-Annually	After a Change That May Alter Performance	Comment
Pressure drop across empty test section (11.2)	X			
Background particle count (12.2)	X			
Particle counter zero check (7.6)	X			
Particle counter primary calibration using PSL				Note 1
Air velocity uniformly (7.2)			X	
Aerosol uniformity (7.3)			X	
Generator response time (7.5)			X	
Overloading test of particle counter (7.4)			X	
Confirmation of neutralizer radioactivity (7.8)		X		Note 2
Flow rates, pressure drops, temperature, relative humidity, and so forth				Note 3
Cleaning of test duct and components				Note 4

NOTE 1—Calibration performed annually

NOTE 2—Wash the inside of radioactive neutralizer every 1-h of use. Check balance of the corona discharge ionizer monthly, per manufacturer's instructions.

NOTE 3—In accordance with manufacturer's recommendations but at least annually.

NOTE 4—Cleaning intervals of the test duct, aerosol generator system, aerosol sampling lines, and other test components is discretionary.

application with no additional sealing except openings larger than 1/8-in. wide at the ends.

9.3.1 If the devices do not span the entire hood opening provided in the test facility, spacers must be installed on each end to center the test devices in the hood and to prevent air from passing around the ends.

9.3.2 If the devices cannot be installed in the existing hood at the test facility, a new 4-ft wide exhaust hood with the appropriate mounting hardware shall be installed in the facility and characterized as in Section 8, or the mounting hardware in the existing hood shall be changed to accommodate the devices as they would be installed in the field.

9.4 At the beginning of every test, the airflow must be verified to be within 5 % of that obtained from a new filter at the same pressure drop.

10. Procedure

10.1 Airflow Rates for Tests:

10.1.1 Particle size efficiency tests shall be run and reports generated for an airflow rate as specified in either 10.1.2 or 10.1.3.

10.1.2 The total airflow rate through the exhaust system is set so that the volumetric flow rate through the filter under test is equivalent 250 cfm per linear foot (width) of filter device (based on external filter dimensions).

10.1.3 Performance may also be evaluated at other airflows in accordance with manufacturer recommendations (see Appendix X1).

10.2 Test Sequence:

10.2.1 The sequence of tests on the device(s) shall be as follows:

10.2.1.1 Resistance versus airflow rate as described in Section 10.3.

10.2.1.2 Particle size collection efficiency as described in Section 10.4.

10.3 Measurement of Resistance to Airflow:

10.3.1 The airflow rate shall be determined using one of the methods described in Section 6.3.1.

10.3.2 Remove any test device(s) from the exhaust hood.

10.3.3 Measure and record the differential pressure between the static pressure tap installed in the hood downstream of the test device(s) and the room air in the test facility at a minimum of four airflow rates: 50 %, 75 %, 100 %, and 125 % of test airflow rate.

10.3.4 Install the device(s) in the exhaust hood as described in Section 9.

10.3.4.1 If testing removable baffle filter or cartridge filter, install the device(s) in the exhaust hood as described in Section 9.

10.3.4.2 If testing a hood with a fixed extractor, remove reference hood and install test hood. To save on the number of set-ups, this may be delayed and done in conjunction with 10.4.2.

10.3.5 Repeat measurements described in 10.3.3. If testing a hood with a fixed extractor, this may be delayed and done in conjunction with 10.4.2.

10.4 Particle Size Collection Efficiency:

10.4.1 The aerosol sampling sequence for removable grease filters and cartridge filters shall consist of the following steps:

10.4.1.1 *No Device in Hood*—Sample background aerosol twice without generator operating.

10.4.1.2 *Device(s) in Hood*—Sample background aerosol twice without generator operating.

10.4.1.3 *No Device in Hood*—Sample with aerosol generator turned on after sufficient time to reach steady emission following the results of tests described in 8.5.1.

10.4.1.4 Turn aerosol generator off and install device(s) to be tested in hood.

10.4.1.5 *Device(s) in Hood*—Sample with aerosol generator turned on after sufficient time to reach steady emission following the results of tests described in 8.5.1.

10.4.1.6 Turn the aerosol generator off and remove test device(s) from the hood.

10.4.1.7 *No Device in Hood*—Sample with aerosol generator turned on after sufficient time to reach steady emission following the results of tests described in 8.5.1.

10.4.1.8 Repeat 10.4.1.3 – 10.4.1.7 for as many sample sets as necessary to meet data requirements for the reported data.

10.4.1.9 *No Device in Hood*—Sample background aerosol twice without generator operating.

10.4.1.10 *Device(s) in Hood*—Sample background aerosol twice without generator operating

10.4.2 The aerosol sampling sequence for fixed extractors shall consist of the following steps:

10.4.2.1 *Reference Hood, No Device in Hood*—Sample background aerosol without generator operating,

10.4.2.2 *Reference Hood, No Device in Hood*—Sample with aerosol generator turned on after sufficient time to reach steady emission following the results of tests described in 8.5.1.

10.4.2.3 Turn aerosol generator off.

10.4.2.4 Remove reference hood and replace with fixed extractor hood. Care must be taken to insure setup of aerosol generator, ductwork, and aerosol sampling equipment is not disturbed or is setup identical to prior to switching hood.

10.4.2.5 If not done previously, complete differential pressure measurements for 10.3.4 and 10.3.5.

10.4.2.6 *Fixed Extractor Hood Installed*—Sample background aerosol without generator operating.

10.4.2.7 *Fixed Extractor Hood Installed*—Sample with aerosol generator turned on after sufficient time to reach steady emission following the results of tests described in 8.5.1.

10.4.2.8 Turn aerosol generator off.

10.4.2.9 Remove fixed extractor and replace with reference hood. Care must be taken to insure setup of aerosol generator, ductwork, and aerosol sampling equipment is not disturbed or is setup identical to prior to switching hood.

10.4.2.10 *Reference Hood, No Device in Hood*—Sample with aerosol generator turned on after sufficient time to reach steady emission following the results of tests described in 8.5.1.

10.4.2.11 Repeat 10.4.2.1 – 10.4.2.10 (except 10.4.2.5) as many times as necessary to meet data requirements for the reported data.

10.4.2.12 *Reference Hood, No Device in Hood*—Sample background aerosol without generator operating.

10.5 Penetration:

10.5.1 The device(s) shall be installed in the test facility for determination of particle penetration as a function of particle size. For the purposes of this test method, penetration P shall be the fraction of particles approaching the device(s) that pass through. The general equation to determine penetration at any particle size shall be:

$$P = \left(\frac{\text{particle concentration with test device(s) installed}}{\text{particle concentration without test device(s) installed}} \right) \quad (3)$$

with the particle concentration measured in the exhaust duct downstream of the device(s) and the particle generator on.

10.5.2 Background counts shall be made before generating test aerosols. The background counts shall be made with no test device(s) installed in the hood.

10.5.3 Start generating the oleic acid aerosol when background counts are complete. Start sampling with no test device(s) installed. Follow the test sequence outlined in 10.4.1. A difference between sampling time with no device(s) installed, T_{wo} , and sampling time with a test device(s) installed, T_w , is allowable.

10.5.4 Aerosol generation shall be turned off and background sampling shall be repeated with no test device(s) installed in the hood after completion of the required penetration sampling sets.

10.5.5 Particle penetration through the test device(s) shall then be calculated in accordance with 11.6.

11. Calculation and Reporting

11.1 Test results shall be reported using the test report format shown in this test method. Figs. 10-13 comprise the complete test report and are examples of acceptable forms. Exact formats are not required, but the report shall include the items shown.

11.2 The summary section of the performance report shall include the following information:

11.2.1 Name and location of the test laboratory.

11.2.2 Date of the test.

11.2.3 Test operator's name(s).

11.2.4 Brand and model number of the particle counting and sizing device.

11.2.5 Grease filter manufacturer's name (or name of the marketing organization, if different from the manufacturer).

11.2.6 How the sample was obtained.

11.2.7 Description of the grease filter, including:

11.2.7.1 Brand and model number,

11.2.7.2 Physical description of construction (for example, single stage, two-stage with prefilter, passive or electrically powered),

11.2.7.3 Face dimensions and depth of each module,

11.2.7.4 Number of modules installed in the hood during each test,

11.2.7.5 Total width of installed modules, and

11.2.7.6 Any other pertinent descriptive attributes.

11.2.8 Operating data as stated by the manufacturer:

11.2.8.1 Test conditions for reporting purposes, airflow rate,

11.2.8.2 Pressure drop at rated airflow rate, and

11.2.8.3 Any other operating data furnished.

11.2.9 Test data:

11.2.9.1 Makeup air temperature and relative humidity,

11.2.9.2 Makeup air barometric pressure,

11.2.9.3 Temperature at sampling point in exhaust duct,

11.2.9.4 Airflow rate through the hood and test filters, and

11.2.9.5 Average griddle surface temperature.

11.2.10 Results of pressure drop testing.

11.2.11 Results of filter efficiency testing:

11.2.11.1 A curve in Fig. 12 format for filter efficiency versus particle size, and

11.2.11.2 A table in Fig. 13 format.

11.3 The calculations and data quality requirements of 11.4 – 11.8 are to be performed separately for each of the particle size bins of the particle counter.

11.4 *Aerosol Generator Output and Background Data Reduction:*

11.4.1 The counts from two samples taken without the test device(s) installed that were taken immediately before and after a test with the test device(s) installed shall be arithmetically averaged to obtain an estimate of what the counts would