



Designation: E514/E514M – 20

Standard Test Method for Water Penetration and Leakage Through Masonry¹

This standard is issued under the fixed designation E514/E514M; the number immediately following the designation indicates the year of original adoption or, in the case of revision, the year of last revision. A number in parentheses indicates the year of last reapproval. A superscript epsilon (ϵ) indicates an editorial change since the last revision or reapproval.

This standard has been approved for use by agencies of the U.S. Department of Defense.

1. Scope*

1.1 This laboratory test method² provides a procedure for determining the resistance to water penetration and leakage through unit masonry subjected to wind-driven rain. This test method is not identical to and the results are not the same as field standard Test Method C1601. This test method measures through-wall water penetration, whereas Test Method C1601 only measures surface water penetration.

1.2 The values stated in either SI units or inch-pound units are to be regarded separately as standard. The values stated in each system may not be exact equivalents; therefore, each system shall be used independently of the other. Combining values from the two systems may result in non-conformance with the standard.

1.3 *This standard does not purport to address all of the safety concerns, if any, associated with its use. It is the responsibility of the user of this standard to establish appropriate safety, health, and environmental practices and determine the applicability of regulatory limitations prior to use.* For a specific hazard statement, see Section 6.

1.4 *This international standard was developed in accordance with internationally recognized principles on standardization established in the Decision on Principles for the Development of International Standards, Guides and Recommendations issued by the World Trade Organization Technical Barriers to Trade (TBT) Committee.*

2. Referenced Documents

2.1 *ASTM Standards:*³

C270 Specification for Mortar for Unit Masonry

¹ This test method is under the jurisdiction of ASTM Committee C15 on Manufactured Masonry Units and is the direct responsibility of Subcommittee C15.04 on Research.

Current edition approved Dec. 1, 2020. Published December 2020. Originally approved in 1974. Last previous edition approved in 2014 as E514/E514M – 14a. DOI: 10.1520/E0514_E0514M-20.

² This test method is based upon those used by the National Bureau of Standards and described in *NBS Report BMS7*, “Water Permeability of Masonry Walls,” 1933, and *NBS Report BMS82*, “Water Permeability of Walls Built of Masonry Units,” 1942.

³ For referenced ASTM standards, visit the ASTM website, www.astm.org, or contact ASTM Customer Service at service@astm.org. For *Annual Book of ASTM Standards* volume information, refer to the standard’s Document Summary page on the ASTM website.

C1232 Terminology for Masonry

C1601 Test Method for Field Determination of Water Penetration of Masonry Wall Surfaces

2.2 *The Masonry Society Standards:*⁴

TMS 402 Building Code Requirements for Masonry Structures

TMS 602 Specifications for Masonry Structures

3. Terminology

3.1 *Definitions of Terms Specific to This Standard:*

3.1.1 *dampness, n*—visual change in the appearance of a material due to the presence of water.

3.1.2 *surface water penetration, n*—passage of water through the exterior face of the masonry.

3.1.3 *through-wall water penetration, n*—passage of water through a wall and appearance of the water on the interior face of the masonry.

3.1.4 *water penetration, n*—water that passes into or through the masonry.

3.1.5 *wind-driven rain, n*—rain water that is directed against the surface of the wall by wind.

3.2 For definitions of other terms used in this test method, refer to Terminology C1232.

4. Significance and Use

4.1 This test method provides information that aids in evaluating the effect of four principal variables: materials, coatings, wall design, and workmanship.

4.2 Water penetration and leakage through masonry is significantly affected by air pressure in the test chamber. Data from tests made at different pressures are not comparable.

4.3 The performance of a masonry wall is a function of materials, construction, wall design, and maintenance. In service the performance will also depend on the rigidity of supporting structure and on the resistance of components to deterioration by various causes, such as corrosion, vibration, thermal expansion and contraction, curing, and others. It is impossible to simulate the complex conditions encountered in

⁴ Published by The Masonry Society, www.masonrysociety.org.

*A Summary of Changes section appears at the end of this standard

service, such as variations in wind velocity, negative pressure, and lateral or upward moving air and water. Factors such as location, exposure, and wall openings should be considered.

4.4 Given the complexity of variables noted above, this test method establishes comparative behavior between various masonry wall constructions in a given laboratory.

4.5 Even when a single laboratory tests the same wall design utilizing the same wall materials and the same construction practices, variables such as the level of skill of the mason building the specimen, the temperature and humidity in the laboratory at the time of construction, curing of the specimen, the moisture contents of the materials used to build the specimen, and even the use or lack of use of a lime and water wash on the back of the specimen can affect the results of the test making reliable comparisons dubious. For these reasons and the multi-variables listed in 4.1, 4.2, and 4.3, a meaningful, useful, absolute wall leakage rating standard is impractical and discouraged.

4.6 This test method is similar to but distinct from field Test Method C1601. This standard is a laboratory test method designed to test laboratory fabricated wall specimens and measures the water that has penetrated into and through the masonry specimen and is collected. Test Method C1601 is a field test method designed to test in-situ walls and measures water penetration of the masonry at its surface. Results from Test Method C1601 and Test Method E514/E514M are not the same.

5. Apparatus

5.1 Test Chamber—Use a test chamber similar to that shown in Fig. 1 and Fig. 2. Provide an opening with a minimum area of 1.08 m² [12 ft²]. For example, 900 mm [36 in.] wide and 1200 mm [48 in.] high is suitable. Line the edges of the chamber in contact with the specimen with a closed-cell compressible gasket material or appropriate sealant. Provide an observation port in the face of the chamber. Provide a 19.0-mm [³/₄-in.] diameter corrosion-resistant spray pipe with a single line of 1.0-mm [0.04-in.] diameter holes spaced 25.0 mm [1 in.] apart.

5.2 Fixtures and Appurtenances to Chamber—Fixtures and appurtenances to the chamber shall include an air line with manometer, a water line with valves, a flow meter and manometer and a water drain pipe at the bottom of the chamber. Position the water spray pipe so that the water impinges the specimen not more than 75.0 mm [3.00 in.] below the top of the test chamber.

NOTE 1—A drain pipe that discharges into a reservoir equipped with an adjustable depth air outlet pipe and top baffles has been found to reduce surge.

5.3 Manometer—Measure the air pressure in the chamber using a manometer or other device capable of measuring air pressures of at least 51 mm [2.0 in.] of water (71.7 kPa [10.4 psf]) to an accuracy of 2.5 mm [0.1 in.] or 3.6 kPa [0.52 psf]. Connect the manometer or other device to the chamber

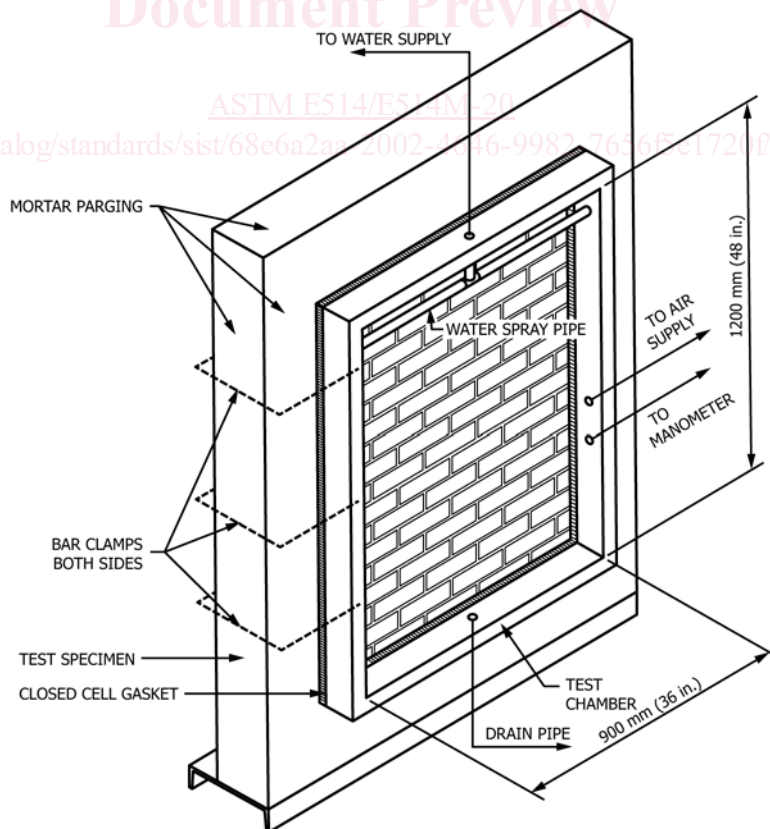

FIG. 1 Isometric Projection of Testing Chamber

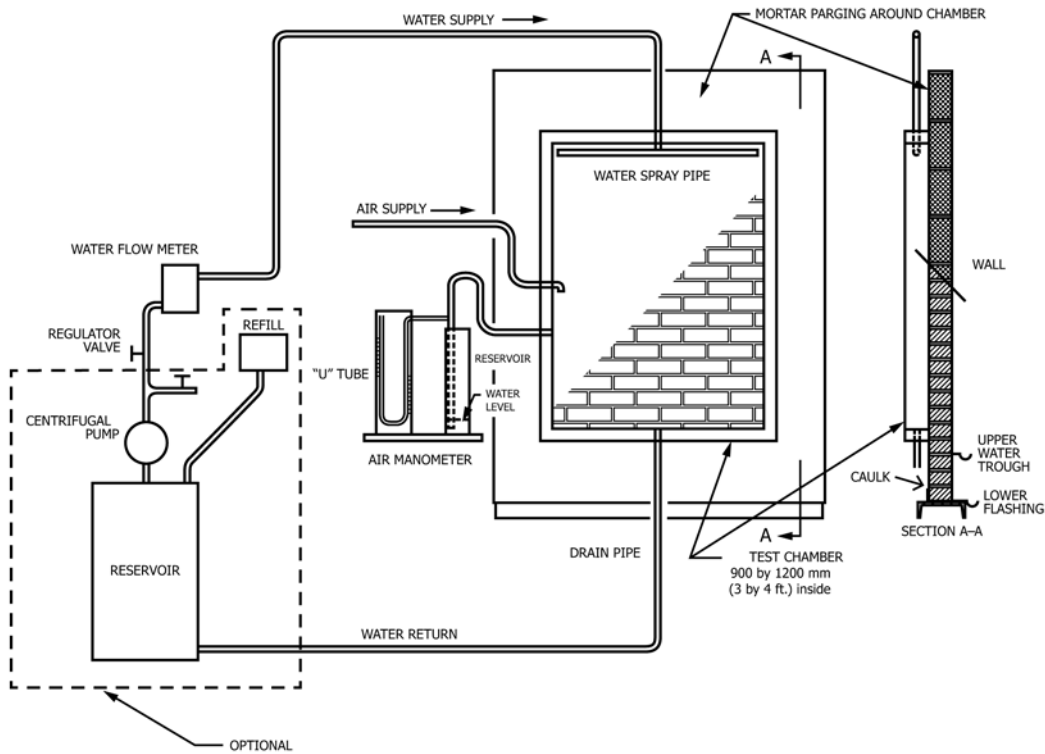

FIG. 2 General Arrangement of Water Penetration Testing Chamber System

away from the air inlet so that the air flow will not significantly influence the pressure reading.

5.4 Other equipment includes devices for handling the specimen and measuring time, water quantities, temperature, and humidity.

6. Hazards

6.1 The use of this test method will require careful design consideration of both air chamber and support of the wall system to avoid possible injury due to equipment or specimen failure.

7. Temperature and Humidity Conditions

7.1 Maintain the air in the laboratory at a temperature of $24 \pm 8^\circ\text{C}$ [$75 \pm 15^\circ\text{F}$] and a relative humidity of $55 \pm 25\%$.

8. Test Specimens

8.1 *Masonry Materials*—Masonry and associated materials shall be representative of the construction or the materials that are being considered. Precondition all materials by storing in laboratory environment for not less than 5 days before use.

8.2 *Size of Test Walls*—The height and length of the specimen shall provide a minimum of 1.08 m^2 [12 ft^2] exposed to the test, plus at least a 200-mm [8-in.] overlap on all edges. The minimum height or length of the specimen shall be 1.22 m [4 ft]. The length of the specimen shall be such that at least one head joint in each course of masonry is exposed to the test.

8.3 *Building Wall Specimens*—Construct the specimen using methods and workmanship being considered for the work (Note 2). Build the wall specimen on an inverted steel channel section as shown in Fig. 2 (Note 3). Also, as shown in Fig. 2, build a lower flashing and upper water trough as described in 8.3.1 and 8.3.2.

NOTE 2—Standards for masonry construction are contained in the following documents: TMS 402 Building Code Requirements for Masonry Structures and TMS 602 Specifications for Masonry Structures.

NOTE 3—The top of the wall may require bracing to be stable.

8.3.1 Install a lower flashing into a mortar joint that is at least one course below the upper water trough. Pass the lower flashing completely through the wall, upturn it on the chamber side, and seal with a bead of caulk. Project this lower flashing out from the backside of the wall with a *u* or *v* profile designed to funnel water that passes through the bottom of the wall into a collection device.

8.3.2 Install an upper water trough in the bed joint immediately below the bottom of the test chamber. Project the upper water trough no more than 25 mm [1.0 in.], or no more than the thickness of a face shell, into a mortar joint on the backside of the wall. Project this upper water trough out from the backside of the wall with a *u* or *v* profile designed to funnel water that penetrates through the wall above the trough into a separate collection device.

8.4 *Number of Specimens*—Test at least 3 specimens.

8.5 *Storage of Specimens*—Retain specimens in the laboratory during storage enclosed in an impervious plastic wrap