



Designation: G105 – 20

Standard Test Method for Conducting Wet Sand/Rubber Wheel Abrasion Tests¹

This standard is issued under the fixed designation G105; the number immediately following the designation indicates the year of original adoption or, in the case of revision, the year of last revision. A number in parentheses indicates the year of last reapproval. A superscript epsilon (ϵ) indicates an editorial change since the last revision or reapproval.

1. Scope

1.1 This test method covers laboratory procedures for determining the resistance of metallic materials to scratching abrasion by means of the wet sand/rubber wheel test. It is the intent of this procedure to provide data that will reproducibly rank materials in their resistance to scratching abrasion under a specified set of conditions.

1.2 Abrasion test results are reported as volume loss in cubic millimetres. Materials of higher abrasion resistance will have a lower volume loss.

1.3 The values stated in SI units are to be regarded as standard. The values given in parentheses after SI units are provided for information only and are not considered standard.

1.4 *This standard does not purport to address all of the safety concerns, if any, associated with its use. It is the responsibility of the user of this standard to establish appropriate safety, health, and environmental practices and determine the applicability of regulatory limitations prior to use.*

1.5 *This international standard was developed in accordance with internationally recognized principles on standardization established in the Decision on Principles for the Development of International Standards, Guides and Recommendations issued by the World Trade Organization Technical Barriers to Trade (TBT) Committee.*

2. Referenced Documents

2.1 ASTM Standards:²

[D2000 Classification System for Rubber Products in Automotive Applications](#)

[D2240 Test Method for Rubber Property—Durometer Hardness](#)

[E11 Specification for Woven Wire Test Sieve Cloth and Test Sieves](#)

¹ This test method is under the jurisdiction of ASTM Committee G02 on Wear and Erosion and is the direct responsibility of Subcommittee G02.30 on Abrasive Wear.

Current edition approved Dec. 1, 2020. Published December 2020. Originally approved in 1989. Last previous edition approved in 2016 as G105 – 16. DOI: 10.1520/G0105-20.

² For referenced ASTM standards, visit the ASTM website, www.astm.org, or contact ASTM Customer Service at service@astm.org. For *Annual Book of ASTM Standards* volume information, refer to the standard's Document Summary page on the ASTM website.

[E122 Practice for Calculating Sample Size to Estimate, With Specified Precision, the Average for a Characteristic of a Lot or Process](#)

[E177 Practice for Use of the Terms Precision and Bias in ASTM Test Methods](#)

[G40 Terminology Relating to Wear and Erosion](#)

2.2 *SAE Standard*:³

[SAE J200 Classification System for Rubber Materials](#)

3. Terminology

3.1 Definitions:

3.1.1 *abrasive wear*—wear due to hard particles or hard protuberances forced against and moving along a solid surface.

3.1.1.1 *Discussion*—This definition covers several different wear modes or mechanisms that fall under the abrasive wear category. These modes may degrade a surface by scratching, cutting, deformation, or gouging (**1 and 2**).⁴ **G40**

4. Summary of Test Method

4.1 The wet sand/rubber wheel abrasion test ([Fig. 1](#)) involves the abrading of a standard test specimen with a slurry containing grit of controlled size and composition. The abrasive is introduced between the test specimen and a rotating wheel with a neoprene rubber tire or rim of a specified hardness. The test specimen is pressed against the rotating wheel at a specified force by means of a lever arm while the grit abrades the test surface. The rotation of the wheel is such that stirring paddles on both sides agitate the abrasive slurry through which it passes to provide grit particles to be carried across the contact face in the direction of wheel rotation.

4.2 Three wheels are required with nominal Shore A Durometer hardnesses of 50, 60, and 70, with a hardness tolerance of ± 2.0 . A run-in is conducted with the 50 Durometer wheel, followed by the test with 50, 60, and 70 Durometer wheels in order of increasing hardness. Specimens are weighed before and after each run and the loss in mass recorded. The logarithms of mass loss are plotted as a function of measured rubber wheel hardness and a test value is determined from a least square line as the mass loss at 60.0 Durometer. It is

³ Available from SAE International (SAE), 400 Commonwealth Dr., Warrendale, PA 15096, <http://www.sae.org>.

⁴ The boldface numbers in parentheses refer to the list of references at the end of this standard.

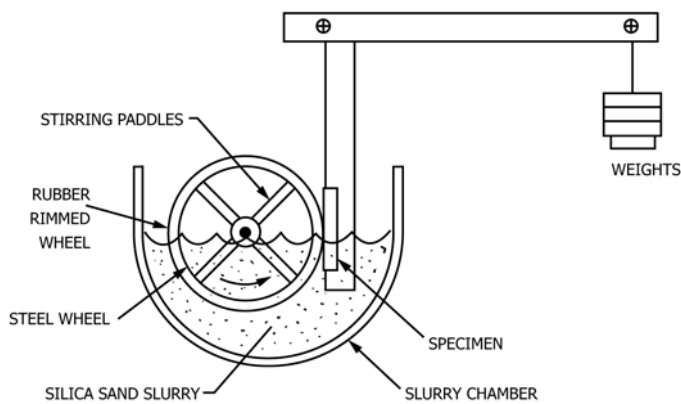

FIG. 1 Schematic Diagram of the Wear Test Apparatus

necessary to convert the mass loss to volume loss, due to wide differences in density of materials, in order to obtain a ranking of materials. Abrasion is then reported as volume loss in cubic millimetres.

5. Significance and Use (1-7)

5.1 The severity of abrasive wear in any system will depend upon the abrasive particle size, shape and hardness, the magnitude of the stress imposed by the particle, and the frequency of contact of the abrasive particle. In this test method these conditions are standardized to develop a uniform condition of wear which has been referred to as scratching abrasion (1 and 2). Since the test method does not attempt to duplicate all of the process conditions (abrasive size, shape, pressure, impact or corrosive elements), it should not be used to predict the exact resistance of a given material in a specific environment. The value of the test method lies in predicting the ranking of materials in a similar relative order of merit as would occur in an abrasive environment. Volume loss data obtained from test materials whose lives are unknown in a specific abrasive environment may, however, be compared with test data obtained from a material whose life is known in the same environment. The comparison will provide a general indication of the worth of the unknown materials if abrasion is the predominant factor causing deterioration of the materials.

6. Apparatus⁵

6.1 Fig. 2 shows a typical design and Figs. 3 and 4 are photographs of a test apparatus. (See Ref (4).) Several elements are of critical importance to ensure uniformity in test results among laboratories. These are the type of rubber used on the wheel, the type of abrasive and its shape, uniformity of the test apparatus, a suitable lever arm system to apply the required force (see Note 1) and test material uniformity.

NOTE 1—An apparatus design that is commercially available is depicted both schematically and in photographs in Figs. 1-4. Although it has been used by several laboratories (including those running interlaboratory tests) to obtain wear data, it incorporates what may be considered a design flaw. The location of the pivot point between the lever arm and the specimen

⁵ Present users of this test method may have constructed their own equipment. Rubber wheel abrasion testing equipment is commercially available. Rubber wheels or remolded rims on wheel hubs can be obtained through the manufacturer(s).

holder is not directly in line with the test specimen surface. Unless the tangent to the wheel at the center point of the area or line of contact between the wheel and specimen also passes through the pivot axis of the loading arm, a variable, undefined, and uncompensated torque about the pivot will be caused by the frictional drag of the wheel against the specimen. Therefore, the true loading of specimen against the wheel cannot be known.

6.1.1 Discussion—The location of the pivot point between the lever arm and the specimen holder must be directly in line with the test specimen surface. Unless the tangent to the wheel at the center point of the area or line of contact between the wheel and specimen also passes through the pivot axis of the loading arm, a variable, undefined, and uncompensated torque about the pivot will be caused by the frictional drag of the wheel against the specimen. Therefore, the true loading of specimen against the wheel cannot be known.

6.2 Rubber Wheel—Each wheel shall consist of a steel disk with an outer layer of neoprene rubber molded to its periphery. The rubber is bonded to the rim and cured in a suitable steel mold. Wheels are nominally 178 mm (7 in.) diameter by 13 mm (½ in.) wide (see Fig. 2). The rubber will conform to Classification D2000 (SAE J200).

6.2.1 The 50 Durometer wheel will be in accordance with 2BC515K11Z1Z2Z3Z4, where:

- Z1—Elastomer—Neoprene GW,
- Z2—Type A Durometer hardness 50 ± 2,
- Z3—Not less than 50 % rubber hydrocarbon content, and
- Z4—Medium thermal black reinforcement.

6.2.2 The 60 Durometer wheel will be in accordance with 2BC615K11Z1Z2Z3Z4, where:

- Z1, Z3, and Z4 are the same as for 6.2.1, and
- Z2—Type A Durometer hardness 60 ± 2.

6.2.3 The 70 Durometer wheel will be in accordance with 2BC715K11Z1Z2Z3Z4, where:

- Z1, Z3, and Z4 are the same as for 6.2.1, and
- Z2—Type A Durometer hardness 70 ± 2.

6.2.4 The compounds suggested for the 50, 60, and 70 Durometer rubber wheels are as follows:

Ingredient	Content (pph)		
	50	60	70
Neoprene GW	100	100	100
Magnesia ^A	2	2	2
Zinc Oxide ^B	10	10	10
Octamine	2	2	2
Stearic Acid	0.5	0.5	0.5
SRF Carbon Black ^C	20	37	63
ASTM #3 Oil	14	10	10

^A Maglite D (Merck)
^B Kadox 15 (New Jersey Zinc)
^C ASTM Grade N762

6.2.5 Wheels are molded under pressure. Cure times of 40 to 60 min at 153°C (307°F) are used to minimize “heat-to-heat” variations.

6.3 Motor Drive—The wheel is driven by a 0.75 kw (1 hp) electric motor and suitable gear box to ensure that full torque is delivered during the test. The rate of revolution (245 rpm ± 5 rpm) must remain constant under load. Other drives producing 245 rpm under load are suitable.

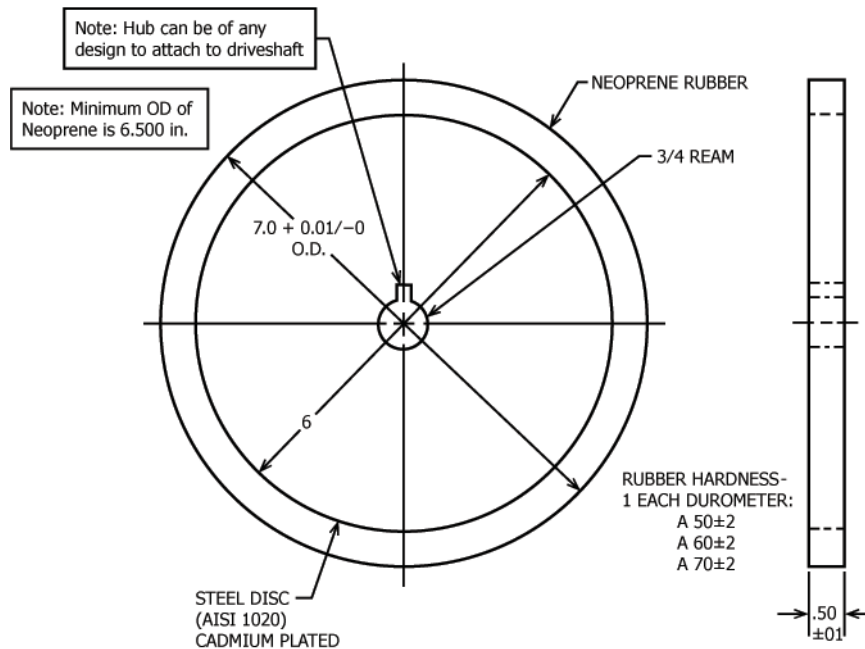

FIG. 2 Rubber Wheel

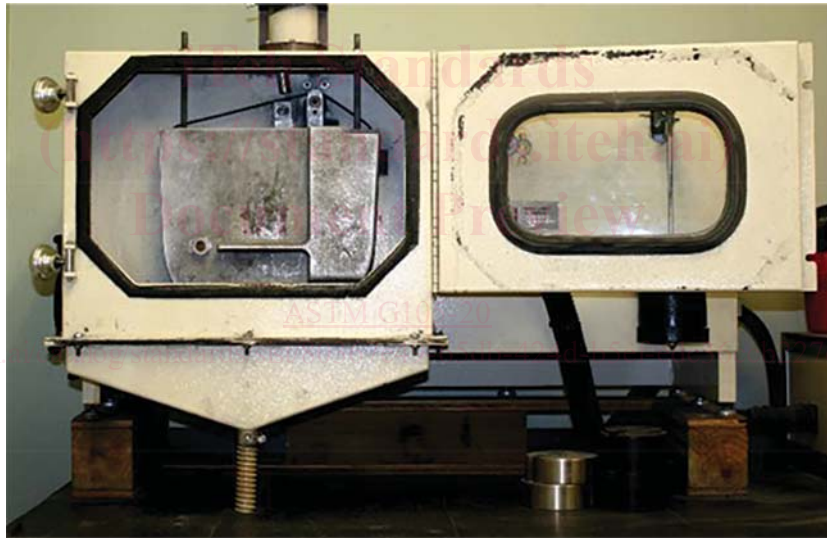

FIG. 3 Test Apparatus with Slurry Chamber Cover Removed

6.4 *Wheel Revolution Counter*—The machine shall be equipped with a revolution counter that will monitor the number of wheel revolutions as specified in the procedure. It is recommended that the incremental counter have the ability to shut off the machine after a preselected number of wheel revolutions or increments up to 5000 revolutions is attained.

6.5 *Specimen Holder and Lever Arm*—The specimen holder is attached to the lever arm to which weights are added so that a force is applied along the horizontal diametral line of the wheel. An appropriate weight must be used to apply a force of 222 N (50 lbf) between the test specimen positioned in the specimen holder and the wheel. The weight has a mass of approximately 9.5 kg (21 lb) and must be adjusted so that the force exerted by the rubber wheel on the specimen with the

rubber wheel at rest has a value of 222.4 N ± 3.6 N (50.0 lbf ± 0.8 lbf). This force may be determined by calculation of the moments acting around the pivot point for the lever arm or by direct measurement, for example, by noting the load required to pull the specimen holder away from the wheel, or with a proving ring.

6.6 *Analytical Balance*—The balance used to measure the loss in mass of the test specimen shall have a sensitivity of 0.0001 g. A 150 g capacity balance is recommended to accommodate thicker or high density specimens.

7. Reagents and Materials

7.1 *Abrasive Slurry*—The abrasive slurry used in the test shall consist of a mixture of 0.940 kg of deionized water and



FIG. 4 Test Apparatus in Operation

1.500 kg of a rounded grain quartz sand as typified by AFS 50/70 Test Sand (−50/ +70 mesh, or −230/+270 μm) furnished by the qualified source.⁶

7.2 AFS 50/70 test sand is controlled by the qualified source to the following size range using U.S. Sieves (Specification E11).

U.S. Sieve Size	Sieve Opening	%Retained on Sieve
40	425 μm (0.0165 in.)	None
50	300 μm (0.0117 in.)	5 max
70	212 μm (0.0083 in.)	95 min
100	150 μm (0.0059 in.)	None Passing

7.2.1 Multiple use of the sand may affect the test comparisons.

8. Sampling, Test Specimen, and Test Units

8.1 *Test Unit*—Use any metallic material form for abrasion testing by this method. This includes wrought metals, castings, forgings, weld overlays, thermal spray deposits, powder metals, electroplates, cermets, etc.

8.2 *Test Specimen*—The test specimens are rectangular in shape, 25.4 mm ± 0.8 mm (1.00 in. ± 0.03 in.) wide by 57.2 mm ± 0.8 mm (2.25 in. ± 0.03 in.) long by 6.4 mm to 15.9 mm (0.25 in. to 0.625 in.) thick. The test surface should be flat within 0.125 mm (0.005 in.) maximum.

8.2.1 For specimens less than 9.5 mm (0.375 in.) thick, use a shim in the specimen holder to bring the specimen to a height of 9.5 mm.

8.3 *Wrought and Cast Metal*—Specimens may be machined to size directly from raw material.

8.4 Weld deposits are applied to one flat surface of the test piece. Double-weld passes are recommended to prevent weld dilution by the base metal. Note that welder technique, heat

⁶ The sole source of supply of the apparatus known to the committee at this time is Ottawa Silica Co., P.O. Box 577, Ottawa, IL 61350. If you are aware of alternative suppliers, please provide this information to ASTM International Headquarters. Your comments will receive careful consideration at a meeting of the responsible technical committee,¹ which you may attend.

input of welds, and the flame adjustment of gas welds will have an effect on the abrasion resistance of the weld deposit. Weld deposits should be made on a thick enough substrate, 12.7 mm (0.5 in.) minimum suggested, to prevent distortion. If distortion occurs, the specimen may be mechanically straightened or ground or both.

8.4.1 In order to develop a suitable wear scar, the surface to be abraded must be ground flat to produce a smooth, level surface. A test surface without square (90°) edges, having a level surface at least 50.8 mm (2.00 in.) long and 19.1 mm (0.75 in.) wide, is acceptable if it can be positioned to show the full length and width of the wear scar developed by the test.

8.5 *Coatings*—This test may be unsuitable for some coatings, depending on their thickness, wear resistance, bond to the substrate, and other factors. The criterion for acceptability is the ability of the coating to resist penetration to its substrate during conduct of the test. Modified procedures for coatings may be developed based on this procedure.

8.6 *Finish*—Test specimens should be smooth, flat and free of scale. Surface defects such as porosity and roughness may bias the test results, and such specimens should be avoided unless the surface itself is under investigation. Excepting coatings, the last 0.3 mm (0.01 in.) of stock on the test surface (or surfaces in cases where both major surfaces are to be tested) should be carefully wet ground to a surface finish of about 0.5 μm to 0.75 μm (20 μin. to 30 μin.) arithmetic average as measured across the direction of grinding. The direction of the grinding should be parallel to the longest axis of the specimen. The finished surface should be free of artifacts of specimen heat treatment or preparation such as unintentional carburization or decarburization, heat checks, porosity, slag inclusions, gas voids, etc.

8.6.1 Thin coatings may be tested in the as-coated condition since surface grinding, especially of those less than about 0.3 mm (0.01 in.) thick, can penetrate the coating or cause it to be so thin that it will not survive that test without penetration. The finish of the substrate test surface prior to coating should be

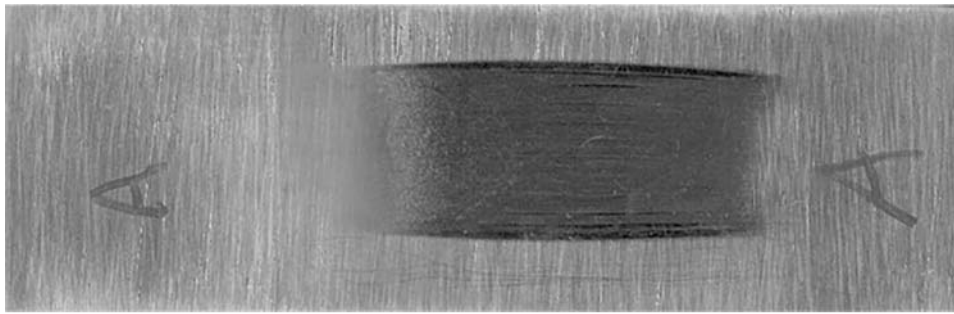

FIG. 5 Typical Uniform Wear Scar

such to minimize irregularities in the coated surface. Grinding of this surface as directed in 8.6 is suggested for coatings less than 0.15 mm (0.005 in.) thick.

8.6.2 The type of surface or surface preparation shall be stated in the data sheet.

9. Procedure

9.1 Thoroughly rinse the slurry chamber before the test to eliminate any remnants of slurry from a previous test.

9.2 Install the rubber wheel of nominal 50 Durometer and measure and record its hardness.

9.2.1 Take at least four (preferably eight) hardness readings at equally spaced locations around the periphery of the rubber wheel using a Shore A Durometer tester in accordance with Test Method **D2240**. Take gage readings after a dwell time of 5 s. Report average hardness in the form: A/48.6/5, where A is the type of Durometer, 48.6 the average of the readings, and 5 the time in seconds that the pressure foot of the tester is in firm contact with the rubber rim surface. The 5 s dwell time for the pressure foot in contact with the rubber rim should be rigorously adhered to.

9.3 Prior to testing, demagnetize each steel specimen. Then clean each specimen of all dirt and foreign matter, and degrease in acetone immediately prior to weighing. Materials with surface porosity (some powder metals or ceramics) must be dried to remove all traces of the cleaning agents that may have been entrapped in the material.

9.4 Weigh the specimen to the nearest 0.0001 g.

9.5 Set the revolution counter to shut off automatically after 1000 wheel revolutions.

9.6 Install the specimen in the specimen holder, using an appropriate shim if the specimen surface is less than 9.5 mm above the holder seat surface; then install the holder in position for testing. Fill the slurry chamber with 1.500 kg of the quartz sand and 0.940 kg of deionized water at room temperature, and place a cover over the top of the slurry chamber to prevent the slurry from splashing out.

9.7 Start wheel rotation. The rubber wheels are rotated at 245 rpm, or 2.28 m/s (449 ft/min) peripheral surface speed.

9.8 Lower the specimen holder carefully against the wheel to prevent bouncing and to apply a force of 222 N (50 lb) against the test specimen. A wear scar is run-in for 1000 wheel revolutions. Each 1000 revolutions produces 558.6 m (1832.6

ft) of lineal abrasion assuming a 177.8 mm diameter wheel. The run-in removes the surface layer and exposes fresh material that is not affected by the surface preparation. Note: ensure wheel rotation and slurry mixing has started prior to loading specimen against wheel.

9.9 Following the run-in, remove the specimen from the slurry chamber. Clean, dry, and reweigh the specimen to the nearest 0.0001 g. Drain the slurry from the chamber and discard it.

9.10 The actual abrasion test is conducted on the same wear scar starting with either the same 50 Durometer rubber wheel used for the run-in, or with another 50 Durometer rubber wheel. It is essential to install the specimen in the specimen holder with the same orientation and position each time.

9.11 Follow the same procedure as used for the run-in, repeating steps 9.1 – 9.9 with the normally 50, 60, and 70 Durometer rubber wheels, in order of increasing hardness.

9.12 *Preparation and Care of Rubber Wheels*—Dress the periphery of all new rubber wheels and make concentric to the bore of the steel disk upon which the rubber is mounted. The concentricity of the rim shall be within 0.05 mm (0.002 in.) total indicator reading on the diameter. The intent is to produce a uniform surface that will run tangent to the test specimen without causing vibration or hopping of the lever arm. The wear scars shall be rectangular in shape and of uniform depth at any section across the width (Fig. 5).

9.12.1 It is recommended that rubber wheels be dressed again after accumulating approximately 6000 revolutions during testing. Experience has shown that more than 6000 revolutions may have an adverse effect on the reproducibility of results.

9.12.2 Dress rubber wheels whenever they develop grooves or striations, or when they wear unevenly so as to develop trapezoidal or uneven wear scars on the test specimen.

9.12.3 The rubber wheel may be used until the diameter is reduced to 165 mm (6.50 in.). The shelf life of the rubber rim may not exceed two years. Store wheels so that there is no force on the rubber surface. New rubber rims may be mounted on steel disks by the qualified source.⁶

9.13 *Wheel Dressing Procedure*—A recommended dressing procedure for the periphery of the rubber rim is to mount the wheel on an expandable arbor in a lathe and grind it square with a freshly dressed grinding wheel such as a Norton

38A60J5VBE, having dimensions of approximately 130 mm × 13 mm × 13 mm (5 in. × ½ in. × ½ in.), rotating at a speed of 3500 rpm, while the rubber wheel rotates at 86 rpm. The rubber wheel should be cross-fed at 0.43 mm (0.017 in.) per revolution. After dressing, measure each rubber wheel carefully to determine the diameter and width of the rubber rim.

10. Calculation of Results

10.1 Test results obtained are three mass loss values in grams corresponding to the three average Durometer hardness values obtained for the nominally 50, 60, and 70 Durometer rubber wheels. Normalize mass loss values to correspond to the travel of a wheel having a diameter of 177.8 mm (7.000 in.) and a width of 12.7 mm (0.500 in.) using the following formula:

Normalized Mass Loss in Grams

$$= \frac{177.8 \times 12.7 \times \text{Actual Mass Loss (g)}}{\text{Actual Diameter (mm.)} \times \text{Actual Width (mm.)}}$$

or

$$= \frac{7.000 \times 0.500 \times \text{Actual Mass Loss (g)}}{\text{Actual Diameter (in.)} \times \text{Actual Width (in.)}}$$

10.2 Plot normalized mass loss values (that is, three values for each sample material) on a logarithmic scale against the corresponding rubber wheel hardness plotted on a linear scale. The final test result is obtained by fitting a least square line to the three data points and solving the equation of the line for the mass loss corresponding to a rubber hardness of exactly 60 Durometer. An example of the procedure is presented in [Appendix X1](#).

10.3 *Volume Loss*—While 60 Durometer normalized mass loss results should be reported and may be used internally in test laboratories to compare materials of equivalent or near equivalent densities, it is essential that all users of the test procedure report their results uniformly as volume loss in reports or publications so that there is no confusion caused by variations in density. Convert mass loss to volume loss as follows:

$$\text{Volume Loss, mm}^3 = \frac{\text{Mass Loss (g)} \times 1000}{\text{Density (g/cm}^3\text{)}}$$

11. Precision and Bias

11.1 The precision and bias of the measurements obtained with this test procedure will depend upon strict adherence to the stated test parameters.

11.1.1 The coefficient of correlation (r) for the three mass loss values determined in a test shall be calculated in accordance with [Annex A1](#). The quantity r varies between -1 and $+1$. Either value means that the correlation is perfect; $r = 0$

means that there is no correlation. Data giving r values between 0.95 and -0.95 should be scrutinized for causes of scatter.

11.2 The degree of agreement in repeated tests on the same material will depend upon material homogeneity, machine and material interaction, and close observation of the test by a competent machine operator.

11.3 Normal variations in the abrasive material, rubber wheel characteristics, and procedure will tend to reduce the accuracy of the test method as compared to the accuracy of such material property tests as hardness or density. Properly conducted tests will, however, maintain a 7 % or less coefficient of variation of volume loss values that will characterize the abrasion resistance of materials (see [Annex A1](#)).

11.4 *Initial Machine Operation and Qualification*—The number of tests required to establish the precision of the machine for initial machine operation shall be at least five. The test samples shall be taken from the same homogeneous material.

11.4.1 The standard deviation from the mean average shall be calculated from the accumulated test results and reduced to the coefficient of variation in accordance with [Annex A1](#). The coefficient of variation shall not exceed 7 % in materials of the 2 mm³ to 60 mm³ volume loss range. If this value is exceeded, the machine operation shall be considered out of control and steps taken to eliminate erratic results.

11.4.2 In any test series all data must be considered in the calculation, including outliers (data exceeding the obvious range). For example, an exceedingly high or low volume loss must not be disregarded except in the case of observed faulty machine operation, or obvious test specimen anomaly.

11.5 While two or more laboratories may develop test data that is within the acceptable coefficient of variation for their own individual test apparatus, their actual averages may be relatively far apart. The selection of sample size and the method for establishing the significance of the difference in averages shall be agreed upon between laboratories and shall be based on established statistical methods Practice [E122](#), Practice [E177](#), and *ASTM STP 15D*.⁷

11.6 Reference materials should be used for periodic monitoring of the test apparatus and procedures in individual laboratories. (A satisfactory reference material for this test has not yet been established through laboratory testing.)

12. Keywords

12.1 abrasive wear test; metallic materials; rubber wheel; scratching abrasion; wet sand

⁷ *Manual on Presentation of Data and Control Chart Analysis, ASTM STP 15D*, ASTM International, 1976 (out of print). (Revised as MNL7A, *Manual on Presentation of Data and Control Chart Analysis*, Seventh Edition.)

A1. SOME STATISTICAL CONSIDERATIONS IN ABRASION TESTING

A1.1 *Background*—The wet sand/rubber wheel abrasion test as developed and described by Haworth, Borik, and others (see Refs (1-4), p. 18) has been in various stages of evolution and use over the last two or more decades. A number of variations of this test procedure have been used by several research and industrial laboratories in the United States who were faced with the problem of evaluating hardfacing alloys, castings, and wrought products for their resistance to abrasive wear. Individual laboratories set their own test parameters with the goal being the generation of reproducible test data within the laboratory. As the need for standardization became apparent, in 1962 The Society of Automotive Engineers established a division (No. 18) of the Iron and Steel Technical Committee (ISTC) to achieve this end. This was not accomplished and in 1983, subcommittee G02.30 formed a task group with the objective of producing an ASTM Standard Practice. In previous round-robins conducted by the SAE group, it has been evident that the variability of experimental error inherent in each laboratory is a factor that must be considered. Not only must the test method, apparatus, and individual operator generate correct results (bias) but the test results must be consistently reproducible (precision) within an acceptable narrow range. Another important consideration in developing accurate and precise test results is the selection of adequate sample size. More specifically this was the need for laboratories to agree on the number of times a test should be repeated on a given homogeneous material in order to obtain a meaningful average result. While the single test results and simple arithmetic averaging may in some few cases be useful in individual laboratories, it is essential that statistical techniques and multiple testing of specimens be utilized for the qualification of each test apparatus, and for the comparison of materials. Further information on statistical methods may be found in Practice E122, STP 15D,⁷ and in the references.

A1.2 *Statistical Formulas*—Several formulas for the calculation of optimum sample size, standard deviation, and coefficient of variation are used in the statistical analysis of data. To ensure uniformity among laboratories using the wet sand/rubber wheel test, the standard deviation and coefficient of variation of results produced from a series of tests shall be calculated by the following formulas:

- s = standard deviation (small sample size, 2 to 10) = R/d_2 (1)
- s = standard deviation (any sample size)
= $\sqrt{\sum(x-\bar{x})^2/(n-1)}$ (2)
- V = % coefficient of variation = $(s/\bar{x}) \times 100$ (3)
- n = sample size (95 % confidence level)
= $(1.96 V/e)^2$ (4)

where:

- s = standard deviation from the mean,
- V = variability of the test procedure, %,
- x = value of each test result (volume loss in mm³),
- \bar{x} = mean of arithmetic average for n tests,

TABLE A1.1 Minimum Acceptable Sample Size (n) for 95 % Confidence Level

n	Allowable Sampling Error (%)									
	Coefficient of Variation (V)									
	1 %	2 %	3 %	4 %	5 %	6 %	7 %	8 %	10 %	
1	4	1
2	16	4	2	1
3	35	9	4	3	2	1
4	62	16	7	4	3	2	2
5	96	24	11	6	4	3	2	2	1	...
6	...	35	16	9	6	4	3	2	2	...
7	...	47	21	12	8	6	4	3	2	...
8	...	62	28	16	10	7	5	4	3	...
9	...	78	35	20	13	9	7	5	4	...
10	...	96	43	24	16	11	8	6	4	...

- $\sum x$ = sum total of all test values,
- n = number of tests or observations,
- e = allowable sampling error, %,
- R = difference between the highest and lowest test value, and
- d_2 = deviation factor, which varies with sample size (Table A1.1)

A1.3 *Use of Statistical Methods*—In evaluating the precision and accuracy of any test procedure, new users must deal with the concepts of mean averages, standard deviation from the mean, variability of test results, range of results, allowable sampling error, and particularly the effect of sample size. While it is obvious that a large number of tests on the same material is desirable and will yield a high confidence level in evaluating test results, many abrasion test evaluations are made on a small number of samples. This is due to the fact that in much abrasion work, large numbers of test specimens are just not available. In addition to this a new user is concerned with evaluating the accuracy of his first few (2 or 3) test results during the initial test campaign which certainly should not inspire much confidence because of the small number of tests. However, even with this admittedly small sample size, the user may calculate the variability of results, which may give a general indication of precision of the apparatus and test method. As more data are accumulated from the same homogeneous material and new data are accumulated from different materials, the accumulated variability values may be averaged to provide a better estimate of the precision of the apparatus and procedure.

A1.4 *Small Sample Size (2 to 10):*

A1.4.1 In statistical analysis the estimated standard deviations of large sample sizes (over 10) are derived from the square root of the mean square of deviations from the average. A typical user of this test procedure will more likely start out with less than 10 test results. In these cases the standard deviation(s) is more efficiently derived from the range (R) of