



Designation: C1824 – 16 (Reapproved 2021)

Standard Test Method for Full Scale Bending Test of Spun Prestressed Concrete Bases for Tapered Steel Lighting Poles¹

This standard is issued under the fixed designation C1824; the number immediately following the designation indicates the year of original adoption or, in the case of revision, the year of last revision. A number in parentheses indicates the year of last reapproval. A superscript epsilon (ϵ) indicates an editorial change since the last revision or reapproval.

1. Scope

1.1 This test method covers determination of ultimate bending moment capacity and cracking moment capacity of concrete bases used as foundations for tapered steel lighting poles in accordance to Specification C1804.

1.2 The values stated in inch-pound units are to be regarded as standard. The values given in parentheses are mathematical conversions to SI units that are provided for information only and are not considered standard.

1.3 *This standard does not purport to address all of the safety concerns, if any, associated with its use. It is the responsibility of the user of this standard to establish appropriate safety, health, and environmental practices and determine the applicability of regulatory limitations prior to use.*

1.4 *This international standard was developed in accordance with internationally recognized principles on standardization established in the Decision on Principles for the Development of International Standards, Guides and Recommendations issued by the World Trade Organization Technical Barriers to Trade (TBT) Committee.*

2. Referenced Documents

2.1 *ASTM Standards:*

C39/C39M Test Method for Compressive Strength of Cylindrical Concrete Specimens

C192/C192M Practice for Making and Curing Concrete Test Specimens in the Laboratory

C1804 Specification for Spun Cast Prestressed Concrete Bases for Tapered Steel Lighting Poles

3. Terminology

3.1 *Definitions:*

3.1.1 *cracking load*—a load which creates a bending moment of enough magnitude to produce a tensile stress greater

¹ This test method is under the jurisdiction of ASTM Committee C27 on Precast Concrete Products and is the direct responsibility of Subcommittee C27.20 on Architectural and Structural Products.

Current edition approved Jan. 1, 2021. Published January 2021. Originally approved in 2016. Last previous edition approved in 2016 as C1824 – 16. DOI: 10.1520/C1824-16R21.

than the sum of induced compression plus the tensile strength of the concrete resulting in tensile cracks on the tension face of the base.

3.1.2 *cylindrical section*—lower portion of base designed to be buried in concrete backfill below ground line.

3.1.3 *ground line*—the distance from the butt end of the base to the point where theoretical embedment in the foundation is specified (theoretical buried depth).

3.1.4 *second crack (re-cracking) load*—the load at which a previously formed crack will reopen.

3.1.5 *spun base*—a base in which the concrete is distributed and compacted through centrifugal force.

3.1.6 *tapered section*—upper portion of base, which has a taper designed to match overlapping steel pole taper.

3.1.7 *ultimate load*—maximum test load the base will carry in the specified direction before the steel or concrete will reach its limiting state.

4. Summary of Test Method

4.1 This test consists of applying transverse loads at a predetermined distance to simulate bending moments induced by wind forces exerted on the spun concrete base. The base is tested in a horizontal orientation. The concrete base specimen is laterally supported at two locations: at the ground line and near the bottom end of the base. The bending load is applied through a steel test arm consisting of a matching taper steel adaptor with appropriate extension, which is of sufficient length to deem shear effects negligible. Bending loads are applied gradually at a predetermined loading sequence. The test bending moment is determined by multiplying the moment arm measured from the simulated ground line to the load application point multiplied by the applied load value. Due to the relatively short height of these bases extending above ground line in comparison to the entire structure height, obtaining deflection data is not required.

5. Significance and Use

5.1 This test method is intended to provide the user with acceptable apparatus requirements and a prescribed procedure to determine the bending moment capacity of spun pre-stressed concrete bases for use with tapered steel poles.

5.2 The results of this test method are used as a basis for verification of calculated bending moment capacity, quality control tool for manufacturing process and as a basis for determining statistical bending moment capacity.

5.3 This test method shall not be used for full length prestressed concrete, steel, or composite poles.

6. Apparatus

6.1 *General Requirements*—The test area, fixtures and adaptors shall be sized to accommodate the largest test specimens with adequate margin to include upper tolerances of test specimens. The general layout shall allow for application of transverse loads in direction perpendicular to the centerline of test specimen (see Fig. 1).

6.2 *Loading Apparatus*—The loading apparatus consists of a winch and a steel cable through which the load is applied to the test arm. The winch machine shall be capable of applying loads that are required to test the bases to failure. The loading apparatus shall be capable of applying the required loading sequence in continuous manner. The loading apparatus shall be capable of starting and stopping force application under load, as well as, it shall be capable of maintaining a static load at any point during the test sequence.

6.3 *Test Arm*—The test arm shall consist of tapered steel adaptor and extension. The inside diameter and taper of the adaptor shall match the outside diameter and taper of the test specimen. The extension shall be long enough to allow for a load application point with a moment arm that will ensure that the base primary mode of failure is in flexure with negligible shear effects. The test arm shall be supported by rolling supports to eliminate the effects of gravity loading in the vertical direction perpendicular to the test plane due to the weight of the test arm.

6.4 *Load Cell*—The load cell shall have a capacity greater than the load necessary to test the bases to failure. Resolution of the load cell shall be smaller than 10 lb or 1 % of the ultimate load whichever is greater. The load cell shall be attached to the moment arm extension. The load cell and load cell controller shall have current calibration certificate. Calibration shall be performed annually.

6.5 *Fixturing of Test Specimen*—The test specimen shall be laterally supported at the two reaction points by rigid fixturing brackets with contact area large enough, at least 20 % of the base circumference by 8 in. (200 mm) length, to avoid damage due to stress concentration. The fixturing brackets shall be lined with elastomeric material (Neoprene or SBR sheet rubber) at least ½ in. (12.5 mm) thick and minimum 70 durometer hardness. Alternatively, seasoned oak at least 4 in. (100 mm) thick can be used as a lining material. The distance between the reaction points (center to center of supports) shall not be less than 5.5 ft (1680 mm) to minimize the shear effects at ground line section. The designed ground line location shall be aligned with the edge of support bracket on the loading side. The bottom end of the test specimen shall extend at least 18 in. from the bottom support bracket

7. Setup Tolerances

7.1 The test specimen centerline, extension arm centerline and loading cable shall be located within 2 in. (50 mm) of theoretical test plane.

7.2 The designed test specimen ground line shall be aligned with the edge of ground line support bracket within 1 in. (25 mm).

7.3 The initial load application direction shall be perpendicular to the test specimen centerline within five degrees.

[https://standards.iteh.ai/catalog/standards/sist/7035c330-2f08-4f39-bc73-d2f19b1516dc/astm-c1824-16\(2021\)](https://standards.iteh.ai/catalog/standards/sist/7035c330-2f08-4f39-bc73-d2f19b1516dc/astm-c1824-16(2021))

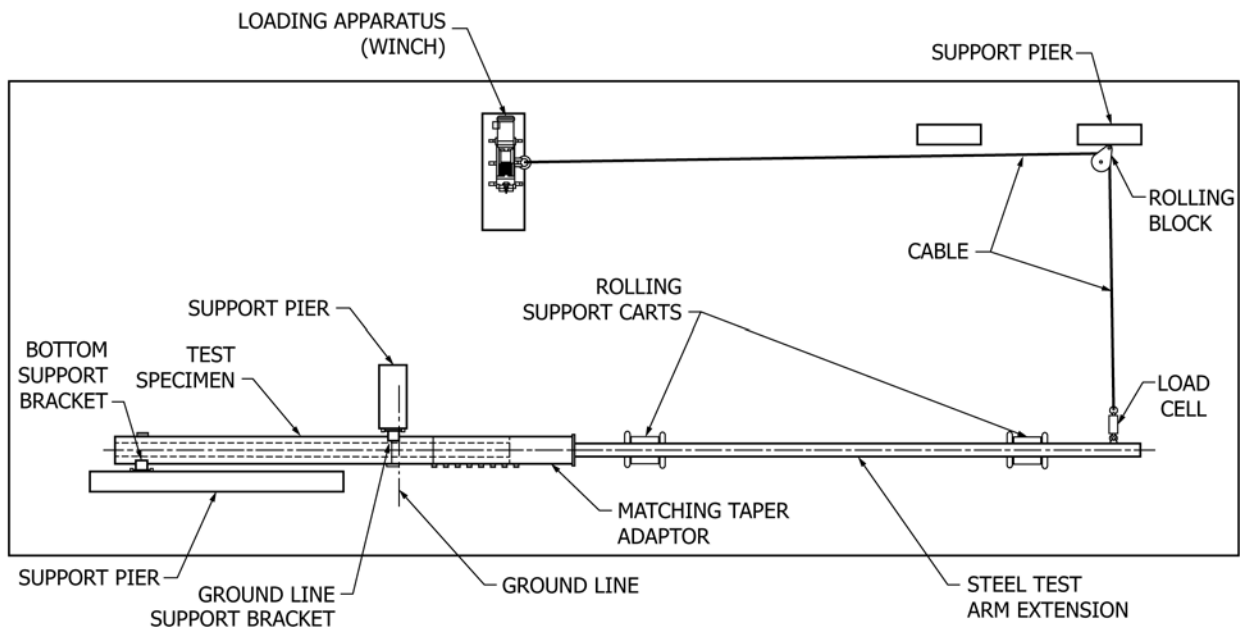

FIG. 1 Horizontal Bending Test Diagram

7.4 Test arm adaptor taper and diameter shall be within design tolerances of matching steel pole shaft.

7.5 Test arm adaptor engagement with the test specimen shall be within tolerance range of designed base to pole overlap.

8. Load Measurement

8.1 Load shall be measured by a suitable measuring device placed in series in the pulling line. The recommended method is a calibrated metal tension bar fitted with calibrated electric-type strain gages, that is, load cell, suitably wrapped or housed for protection against shock when the base breaks. This method permits remote reading of loads and minimizes the possibility of personal injury during test. Alternatively, where electric-type strain gaging equipment is not available, load may be measured by a dynamometer of suitable capacity, graduated in 50 lb (200 N) divisions, maximum increments of 1 % of the rated capacity. Calibration of the dynamometer shall be checked annually as a minimum at frequent intervals during the tests. A dynamometer is not recommended unless the person reading the data can be protected from inadvertent failure of the pulling line or tackle.

9. Test Specimens

9.1 The test specimens shall be manufactured in accordance with standard manufacturing process in accordance with Specification C1804.

9.2 Size and feature dimensions of the test specimens shall be within design tolerances.

9.3 Any damage deemed cosmetic shall be reviewed by a structural engineer prior to testing. Test specimens with damage severe enough to affect structural performance shall not be used for testing.

9.4 Test specimens used for quality control tool for manufacturing process, for design verification, or as a basis for determining statistical bending moment capacity shall be selected randomly and tested at ages between 28 days and 35 days from their manufacturing date.

9.5 Bases may also be tested before 28 days or after 35 days for purposes other than specified in 9.4.

9.6 Base test specimens shall be accompanied by concrete cylinder specimens prepared in accordance with Practice C192/C192M at base manufacturing time. The concrete cylinder specimens shall be tested in accordance with Test Method C39/C39M at strand release time and at 28 days of age.

10. Procedure

10.1 Setup and secure the test specimen in the test apparatus in accordance with Sections 4, 6, 7, and 8 of this standard.

10.2 To determine cracking load apply load and record actual load values in the following sequence:

10.2.1 Apply load in increments of 10 to 20 % of the calculated ultimate load up to 90 % of calculated cracking load.

10.2.2 Apply additional load in smaller increments on the order of 1 % to 5 % of calculated ultimate load. Hold the load after each increment and look for visible crack on the tension

side of the test specimen. Record the load value (cracking load) at which the first crack occurred.

10.2.3 Release the load.

10.3 To determine zero tension moment and ultimate bending moment capacity apply load and record actual load values in the following sequence:

10.3.1 Apply load in increments of 10 to 20 % of the calculated ultimate load up to 70 % of calculated cracking load.

10.3.2 Apply additional load in smaller increments on the order of 1 % to 5 % of calculated ultimate load. Hold the load after each increment and look for visible crack on the tension side of the test specimen. Record the load value (second crack load) at which the first crack reopened.

10.3.3 Increase load to 75 % of the calculated ultimate load and hold for 3 minutes.

10.3.4 Increase load to 90 % of the calculated ultimate load and hold for 3 minutes.

10.3.5 Increase load to 100 % of the calculated ultimate load and hold for 3 minutes.

10.3.6 Continue loading until the base fails. Record the peak load (ultimate load).

11. Determination of Test Moments

11.1 Test moment values for first cracking moment, second crack (zero tension moment), and ultimate bending moment shall be determined according to the following formula:

$$M = L * P / 1000 \quad (1)$$

where:

M = the moment, ft-kip (Nm),

L = moment arm, ft (m), measured from ground line to load attachment point, and

P = recorded test load corresponding to the first crack, second crack (zero tension), and ultimate load respectively, lb (N).

12. Report

12.1 Report shall include the following information:

12.1.1 Test date.

12.1.2 Test specimen production date.

12.1.3 Age of test specimen at time of testing, in days.

12.1.4 Base description, size or part number.

12.1.5 Base geometry, including diameter at ground line.

12.1.6 Taper adaptor overlap.

12.1.7 Moment arm length measured from ground line.

12.1.8 Calculated first cracking moment.

12.1.9 Calculated second crack (zero tension) moment.

12.1.10 Calculated ultimate moment.

12.1.11 Test first cracking moment.

12.1.12 Test second crack (zero tension) moment.

12.1.13 Test ultimate moment.

12.1.14 Type of failure and location.

12.1.15 Concrete cylinder compressive strength data at the following ages: 28 days, prestress release, and at day of test.

12.2 Report may include the following supplementary information, if available:

12.2.1 Photographs of cracks on tension side showing location of first crack.