



Designation: ~~D7313~~—~~13~~ **D7313** – 20

## Standard Test Method for Determining Fracture Energy of ~~Asphalt-Aggregate~~Asphalt Mixtures Using the Disk-Shaped Compact Tension Geometry<sup>1</sup>

This standard is issued under the fixed designation D7313; the number immediately following the designation indicates the year of original adoption or, in the case of revision, the year of last revision. A number in parentheses indicates the year of last reapproval. A superscript epsilon ( $\epsilon$ ) indicates an editorial change since the last revision or reapproval.

### 1. Scope

1.1 This test method covers the determination of fracture energy ( $G_f$ ) of ~~asphalt-aggregate~~asphalt mixtures using the disk-shaped compact tension geometry. The disk-shaped compact tension geometry is a circular specimen with a single edge notch loaded in tension. The fracture energy can be utilized as a parameter to describe the fracture resistance of ~~asphalt concrete mixtures~~. The fracture energy parameter is particularly useful in the evaluation of asphalt mixtures with ductile asphalt binders, such as polymer-modified asphalt ~~concrete mixture~~, and has been shown to discriminate between these materials more broadly than the indirect tensile strength parameter (AASHTO ~~T322~~, ~~Wagoner T 322~~, Ref (1)).<sup>2</sup>: The test is generally valid at temperatures of  $\pm 10^\circ\text{C}$  ( $50^\circ\text{F}$ )– $10^\circ\text{C}$  and below, or for material and temperature combinations which produce valid material fracture, as outlined in 7.4.

1.2 The specimen geometry and terminology (disk-shaped compact tension, DC(T)) is modeled after Test Method E399 for Plane-Strain Fracture Toughness of Metallic Materials, Appendix A6, with modifications to allow fracture testing of ~~asphalt concrete mix.~~

1.3 The test method describes the testing apparatus, instrumentation, specimen fabrication, and analysis procedures required to determine fracture energy of ~~asphalt concrete mixture~~ and similar quasi-brittle materials.

1.4 The text of this test method references notes and footnotes which provide explanatory material. These notes and footnotes (excluding those in tables and figures) shall not be considered as requirements of the test method.

1.5 The values stated in SI units are to be regarded as the standard. ~~The values given in parentheses are for information only. No other units of measurement are included in this standard.~~

1.6 *This standard does not purport to address all of the safety concerns, if any, associated with its use. It is the responsibility of the user of this standard to establish appropriate ~~safety~~ safety, health, and health environmental practices and determine the applicability of regulatory limitations prior to use.*

1.7 *This international standard was developed in accordance with internationally recognized principles on standardization established in the Decision on Principles for the Development of International Standards, Guides and Recommendations issued by the World Trade Organization Technical Barriers to Trade (TBT) Committee.*

<sup>1</sup> This test method is under the jurisdiction of ASTM Committee D04 on Road and Paving Materials and is the direct responsibility of Subcommittee D04.26 on Fundamental/Mechanistic Tests.

Current edition approved Dec. 1, 2013 Dec. 15, 2020. Published January 2014 January 2021. Originally approved in 2007. Last previous edition approved in 2007 2013 as D7313 – 07a D7313 – 13. DOI: 10.1520/D7313-13.10.1520/D7313-20.

<sup>2</sup> Wagoner, M. P., Buttlar, W. G., Paulino, G. H., and Blankenship, P., "Laboratory Testing Suite for Characterization of Asphalt Concrete Mixtures Obtained from Field Cores," The boldface numbers in parentheses refer to a list of references at Journal of the Association of Asphalt Paving Technologists, end of this standard, 2006.

## 2. Referenced Documents

### 2.1 ASTM Standards:<sup>3</sup>

- [D8 Terminology Relating to Materials for Roads and Pavements](#)
- [D3666 Specification for Minimum Requirements for Agencies Testing and Inspecting Road and Paving Materials](#)
- ~~[D6373 Specification for Performance Graded Asphalt Binder](#)~~
- [D6925 Test Method for Preparation and Determination of the Relative Density of Asphalt Mix Specimens by Means of the Superpave Gyrotory Compactor](#)
- [D7643 Practice for Determining the Continuous Grading Temperatures and Continuous Grades for PG Graded Asphalt Binders](#)
- [E177 Practice for Use of the Terms Precision and Bias in ASTM Test Methods](#)
- [E399 Test Method for Linear-Elastic Plane-Strain Fracture Toughness of Metallic Materials](#)
- [E691 Practice for Conducting an Interlaboratory Study to Determine the Precision of a Test Method](#)
- [E1823 Terminology Relating to Fatigue and Fracture Testing](#)

### 2.2 AASHTO Standard:~~Standards:~~<sup>4</sup>

- ~~[AASHTO T 322 Method of Test for Determining the Creep Compliance and Strength of Hot Mix Asphalt \(HMA\) Using the Indirect Tensile Test Device](#)~~
- [AASHTO R 30 Practice for Mixture Conditioning of Hot-Mix Asphalt \(HMA\)](#)

## 3. Terminology

### 3.1 Definitions:

3.1.1 Terminologies [E1823](#) and [D8](#) are applicable to this test method.

~~3.2 Definitions—Definitions of Terms Specific to This Standard: Terminologies [E1823](#) and [D8](#) are applicable to this test method.~~

3.2.1 *crack mouth*—~~the portion of the notch that is on the flat surface of the specimen, that is, opposite specimen (bull nose), perpendicular to the notch tip as identified by letters a and C (see [Fig. 3](#)).~~ [Fig. 3](#).

3.2.2 *crack mouth opening displacement (CMOD)*—the relative displacement of the crack mouth.

3.2.3 *disk-shaped compact tension geometry*—a geometry that utilizes a disk-shaped specimen with a single edge notch as described in Test Method [E399](#).

3.2.4 *2-fracture energy,  $G_f$* —the energy required to create a unit surface area of a crack.

3.2.5 *notch tip*—end of notch where the crack will initiate and propagate.

## 4. Significance and Use

4.1 The test method was developed for determining the fracture resistance of ~~asphalt-aggregate~~ asphalt mixtures. The fracture resistance can help differentiate asphalt mixtures whose service life might be compromised by cracking. The test method is generally valid for specimens that are tested at temperatures of  $10^{\circ}\text{C}$  ( $50^{\circ}\text{F}$ ) ~~10 °C~~ or below (see [Note 1](#)). The specimen geometry is readily adapted to 150 mm diameter specimens, such as fabricated from Superpave (trademark) gyrotory compactors (Test Method [D6925](#)), ~~that which~~ are used for the asphalt ~~concrete~~ mixture design process. The specimen geometry can also be adapted for forensic investigations using field cores of pavements where thin lifts are present. This geometry has been found to produce satisfactory results for asphalt mixtures with nominal maximum aggregates size ranging from 4.75 to 19 ~~mm~~ mm ([2](#)).

NOTE 1—The stiffness of the asphalt binder tends to influence the assessment of a valid test as described in [7.4](#). For instance, a soft asphalt ~~binder~~ binder which may be required for a very cold climate might not lead to a mixture that would produce valid results at  $10^{\circ}\text{C}$  ~~and~~  $+10^{\circ}\text{C}$  and, conversely, a hard asphalt binder utilized in hot climates may require higher temperatures to provide any meaningful information.

NOTE 2—The quality of the results produced by this test method are dependent on the competence of the personnel performing the procedure and the capability, calibration, and maintenance of the equipment used. Agencies that meet the criteria of Specification [D3666](#) are generally considered capable of competent and objective ~~testing/sampling/inspection/etc.~~ testing, sampling, inspection, etc. Users of this test method are cautioned that compliance with Specification [D3666](#) alone does not completely ~~assure~~ ensure reliable results. Reliable results may depend on many factors; following the suggestions of

<sup>3</sup> For referenced ASTM standards, visit the ASTM website, [www.astm.org](http://www.astm.org), or contact ASTM Customer Service at [service@astm.org](mailto:service@astm.org). For *Annual Book of ASTM Standards* volume information, refer to the standard's Document Summary page on the ASTM website.

<sup>4</sup> Available from American Association of State Highway and Transportation Officials (AASHTO), 444 N. Capitol St., NW, Suite 249, Washington, DC 20001, <http://www.transportation.org>.

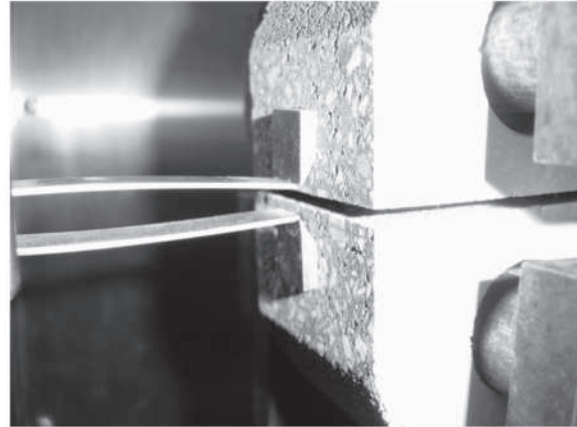
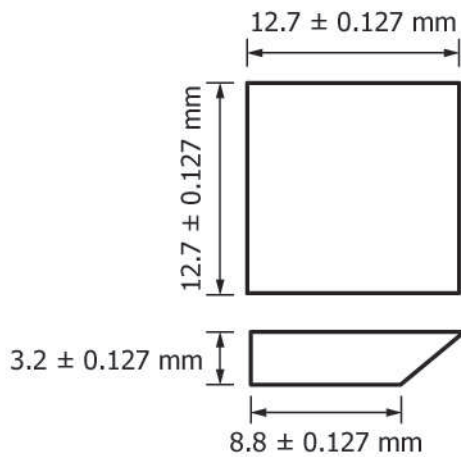

(a) Schematic of Gage Points

(b) Attachment of Clip-on Gage Points

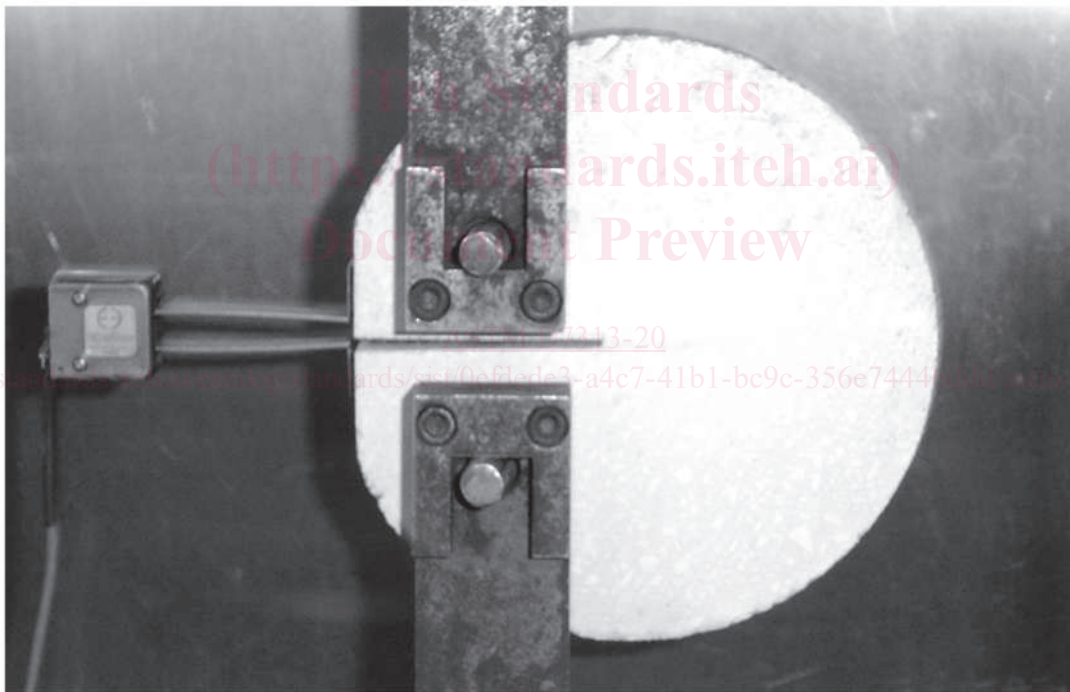

(c) Test Set-up

FIG. 2 Example of Clip-on Gage and Attachment Procedures

Specification D3666 or some similar acceptable guidelines provides a means of evaluating and controlling some of those factors.

NOTE 3—The failure mechanism experienced in this test is influenced by the aggregate type due to the interactive effect of asphalt binder stiffness and aggregate quality on the fracture path and, therefore, fracture energy values. At high values of asphalt binder stiffness, similar to those experienced near the low-temperature performance grade of the asphalt binder, the crack will travel around the aggregate when the mixture includes hard, non-absorptive (for example, granite, trap rock) aggregates resulting in a longer crack path and higher values of fracture energy. For softer, more absorptive aggregates, the crack will travel through the aggregate, shortening the crack path and leading to lower values of fracture energy (3). Due to the influence of aggregate type on fracture energy, mixture design and/or binder grade adjustments in mixes that use softer aggregates may not be sufficient in improving fracture energy to meet a target value.

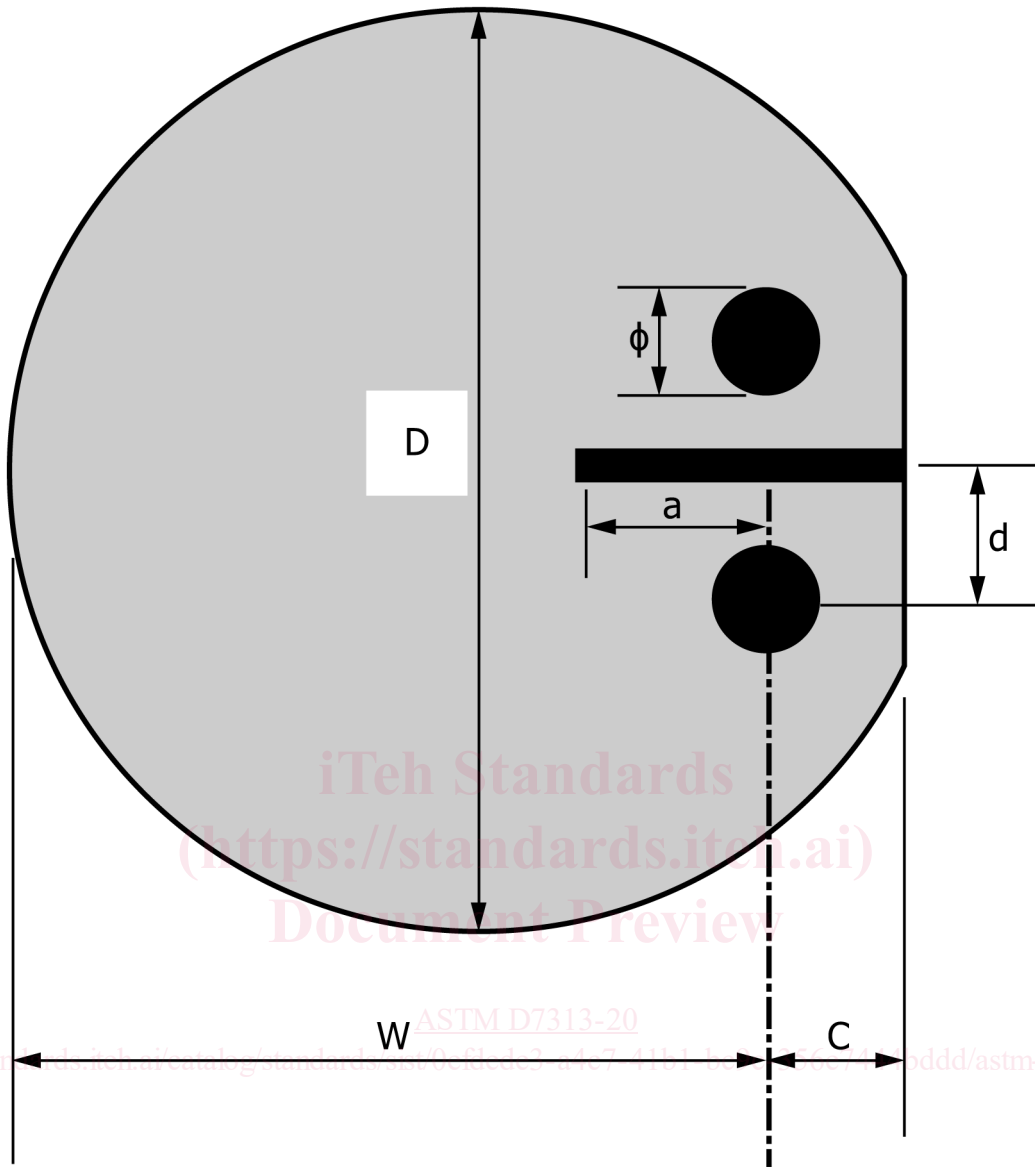

FIG. 3 DC(T) Specimen Dimensions

## 5. Apparatus

5.1 *Loading*—Specimens shall be tested in a loading frame capable of delivering a minimum of 20 kN (4500 lbf) in tension. The load apparatus shall be capable of maintaining a constant crack mouth opening displacement within 2 % of the target value throughout the test. Closed-loop servo-hydraulic or servo-pneumatic test frames are highly recommended, but not required if the CMOD rate meets the specifications listed above. The load cell shall have a resolution of 20 N (4.5 lbf) or better.

5.2 *Loading Fixtures*—An example of a loading clevis suitable for testing of the specimen is shown in Fig. 1. The specimen is loaded through the pins which are allowed to shall roll freely on the flat surfaces of the loading clevis. Any clevis design may be used if the design demonstrates the ability to accomplish the same result. The recommended dimensions of the loading clevis are shown in Fig. 1.

5.3 *Environmental Chamber (Temperature Control System)*—The environmental chamber shall enclose the entire specimen and maintain the specimen at the desired test temperature. The temperature in the environmental chamber shall be monitored using a dummy instrumented specimen of similar geometry as the test specimen within  $\pm 0.5$  °C throughout the conditioning and testing times. Specimens can also be pre-conditioned in a separate environmental chamber that can maintain the temperature of the dummy

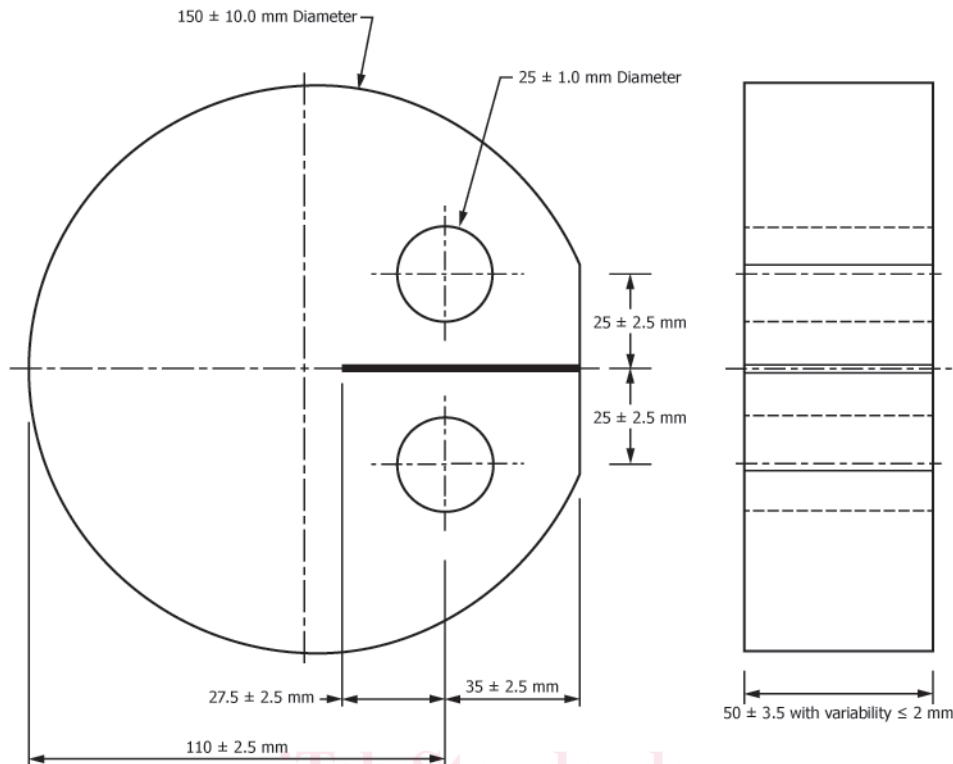

FIG. 3 DC(T) Specimen Dimensions (continued)

instrumented specimen to within  $\pm 0.5\text{ }^{\circ}\text{C}$  throughout the condition period prior to testing. However, [Note 4](#) provides additional guidance on temperature tolerance to improve the test variability.

**NOTE 4**—It is recommended that a  $\pm 0.2\text{ }^{\circ}\text{C}$  tolerance be used for conditioning and testing to lower test variability. Testing temperature tolerance of  $\pm 0.2\text{ }^{\circ}\text{C}$  is recommended on the basis of ruggedness testing performed by ASTM in 2012. While other asphalt cracking performance tests currently use a  $\pm 0.5\text{ }^{\circ}\text{C}$  tolerance: (1) these other tests have not yet gone through ruggedness evaluation to establish the test temperature sensitivity; and (2) these other tests are not conducted at lower test temperatures where variations in temperatures on fracture response of material is more sensitive. Recent works by Dave et al. (4) have shown the impact of test temperature and its sensitivity and supports use of smaller temperature tolerance. Furthermore, at present there are already a number of devices (over 20) that routinely conduct DCT tests with conditioning and testing temperature tolerance of less than  $\pm 0.2\text{ }^{\circ}\text{C}$ .

**5.4 Thermometer**—Temperature of an instrumented dummy specimen shall be measured with resistance temperature detectors (RTDs) or other suitable devices accurate to within  $0.05\text{ }^{\circ}\text{C}$ . The RTD and controller or other suitable devices shall be NIST traceable.

**5.5 CMOD Displacement Gage**—A displacement gage shall be used to measure the relative displacement of the crack mouth across two points, initially  $5\text{ mm}$  ( $0.2\text{ in.}$ ) apart. The gage shall be attached securely to gage points, yet have the ability to be released without damage if the specimen breaks.

**5.5.1** A recommended gage would be a clip-on gage, described in Test Method [E399](#), which is attached to gage points via knife edges. Gage points (see [Fig. 2\(a\)](#)) shall be glued to the specimen so that the clip-on gage is set to the proper gage length, which is typically  $5\text{ mm}$  ( $0.2\text{ in.}$ ), mm. [Fig. 2\(b\)](#) illustrates the attachment of the clip-on gage to the gage points. [Fig. 2\(c\)](#) illustrates the test set-up with the specimen in the fixtures and clip-on gage attached.

**5.5.2** At the beginning of the test, the displacement gage shall have an ability to travel a minimum displacement of  $6.35\text{ mm}$  ( $0.25\text{ in.}$ ), mm.

**5.6 Data Acquisition**—~~Two~~Three channels of data acquisition are required: ~~load~~load, temperature, and CMOD. The acquisition system shall have the ability to acquire the data at a minimum of 25 data points per second.

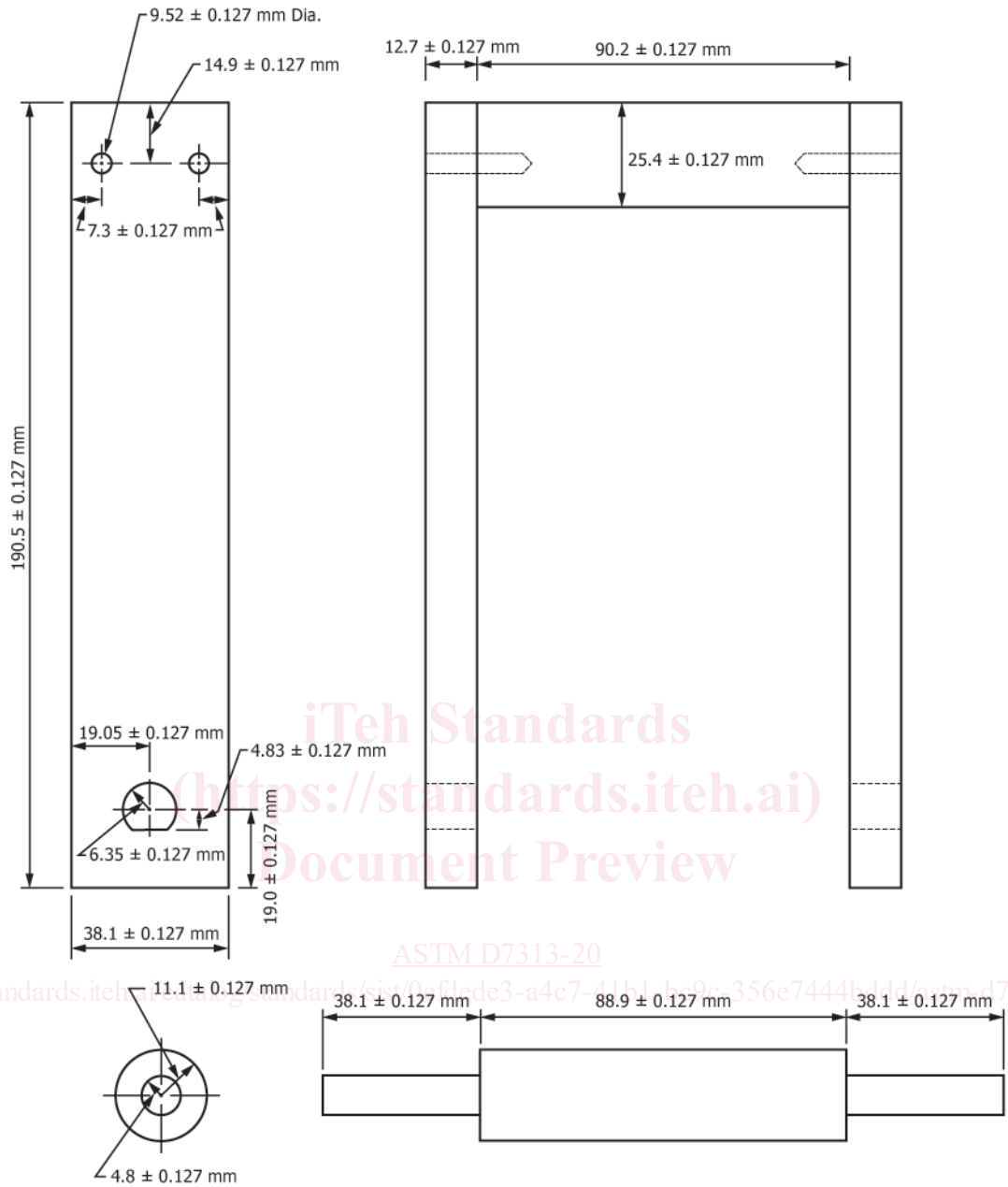

FIG. 1 Schematic of Loading Clevis

NOTE 3—A third channel is recommended for temperature data acquisition. The acquisition system should have the ability to acquire the data at a minimum of 25 data points per second.

## 6. Test Specimens

6.1 Test specimens shall be fabricated in accordance with the dimensions shown in Fig. 3. Typically, a sample 150 mm in diameter by 150 mm in height is fabricated. Two specimens can be cut from the fabricated sample.

6.2 Lab mix lab compacted (LMLC), plant mix lab compacted (PMLC), or reheated plant mix lab compacted (RPMLC) asphalt mixtures may require special curing techniques.

NOTE 5—Heating asphalt mixtures for a period of time prior to compaction may result in specimens having properties that are different from those that are compacted immediately after mixing. Asphalt mixture conditioning, reheat temperature, and reheat time should be defined in the applicable specification.

NOTE 6—Aging of the loose asphalt mixture and/or compacted asphalt mixture and the air voids of the compacted sample can significantly affect the fracture energy of the asphalt mixture. There are references for short-term aging of the loose asphalt mixture such as AASHTO R 30, which is 4 h at 135 °C. AASHTO R 30 also refers to long-term aging of the compacted sample, which is short-term oven aging of the loose asphalt mixture followed by aging of the compacted specimen for five days at 85 °C. Braham et al. (5) proposed 24 h at 135 °C loose mixture aging to simulate long-term aging of the asphalt mixture. The NCHRP project 9-54 titled “Long-Term Aging of Asphalt Mixtures for Performance Testing and Prediction” developed a procedure that is calibrated and validated with field data to simulate long-term aging of asphalt mixtures (6). Recommendations from this study should be considered in selection of long-term aging protocol.

**6.3 Specimen Fabrication**—The equipment used for specimen fabrication shall utilize diamond-impregnated cutting faces and water-cooling to minimize damage to the specimen.

**6.3.1 Specimen Thickness**—The target thickness for laboratory compacted specimens shall be  $50 \pm 5$  mm ( $2 \pm 0.2$  in.) 3.5 mm. The target thickness for field cores should be the lift thickness or  $50 \pm 5$  mm ( $2 \pm 0.2$  in.) 3.5 mm if the lift is greater than 50 mm (2 (see Note 7 in.) in.). The thickness shall be measured at four equally spaced points around the circumference to the nearest  $\pm 0.5$  mm ( $\pm 0.02$  in.) and shall not vary by more than 2.0 mm (0.079 in.) mm.

NOTE 7—Tests have been performed on specimens as small as 25 mm. However, users are cautioned against test specimens below 50 mm in thickness as it may affect test results. A minimum thickness of 25 mm is recommended in instances where field core lift thickness does not allow for the preparation of a 50 mm specimen.

**6.3.2 Notch**—The starter notch shall be fabricated along the diameter of the specimen within  $\pm 1.5$  mm ( $\pm 0.06$  in.) of the location described in Fig. 3 and perpendicular to the faces within  $\pm 1.5$  mm ( $\pm 0.06$  in.)  $\pm 1.5$  mm. The starter notch shall be no wider than 1.5 mm (0.06 in.) mm, with a narrower notch being highly recommended (see Note 48). To expedite the fabrication, a larger notch width can be used to cut up to 90 % of notch length with the remaining cut being 1.5 mm (0.06 in.) 1.5 mm in width.

NOTE 8—The fabrication of the notch is a critical step in providing a valid fracture energy value. value. If the notch varies significantly between replicates, then the value of the fracture energy will be influenced. The notch length is also critical, since providing a fatigue crack of a known length, length as recommended by Test Method E399, is difficult to produce in these materials. However, a notch which is relatively narrow compared to the maximum aggregate size will produce satisfactory results.

**6.3.3 Flat Surface at Crack Mouth**—The flat surface at the crack mouth (bull nose) shall be cut  $90 \pm 5^\circ$  to the notch.

**6.3.4 Loading Holes**—The loading holes shall be fabricated to the size and location as described in Fig. 3 and shall be  $90 \pm 5^\circ$  to the parallel faces of the specimen. The location of the loading holes shall not be greater than 5 mm (0.2 in.) from the specified locations.

**6.3.5 Specimen Diameter, D**—The target diameter for laboratory compacted specimens shall be  $150 \pm 10$  mm. Measurements shall be taken at no less than two points to the nearest  $\pm 0.5$  mm ( $\pm 0.02$  in.) around the circumference of the specimen and then averaged.

**6.3.6 Initial ligament length, (W-a)**—Ligament Length, (W - a)—Measurements—Prior to the test, measurements shall be taken on both sides of the specimen to the nearest  $\pm 0.5$  mm ( $\pm 0.02$  in.) and averaged.

## 7. Procedure

**7.1 Conditioning**—The specimens shall be placed in a ~~temperature-controlled~~ temperature-controlled chamber for a minimum of 82 h and a maximum of 168 h at the desired test temperature. The temperature of an instrumented dummy specimen placed in the temperature-controlled chamber shall be within  $\pm 0.2^\circ\text{C}$  ( $\pm 0.4^\circ\text{F}$ )  $\pm 0.5^\circ\text{C}$  of the test temperature throughout the conditioning and testing times. A suggested See Note 9 test temperature of  $10^\circ\text{C}$  ( $18^\circ\text{F}$ ) greater than the low temperature performance grade of the asphalt binder, as defined in Specification for recommended test temperature, ~~D6373~~, is recommended.

NOTE 9—A suggested test temperature of  $10^\circ\text{C}$  greater than the continuous low-temperature performance grade of the asphalt binder, as defined in Specification D7643, is recommended. The validity of this test to provide measure of asphalt mixture fracture energy has only been determined in low-temperature applications.

**7.2** After temperature conditioning, insert the specimen in loading ~~fixtures and apply fixtures~~. Ensure that test temperature of instrumented dummy within testing chamber stabilizes within  $\pm 0.5^\circ\text{C}$  of desired test temperature. Apply a small seating load of