



Designation: F680 – 20

# Standard Test Methods for Nails<sup>1</sup>

This standard is issued under the fixed designation F680; the number immediately following the designation indicates the year of original adoption or, in the case of revision, the year of last revision. A number in parentheses indicates the year of last reappraisal. A superscript epsilon ( $\epsilon$ ) indicates an editorial change since the last revision or reappraisal.

## 1. Scope\*

1.1 These test methods cover procedures for the testing of nails. The test or tests selected, and the requirements for compliance, will be as specified in the applicable product standard. Performance tests for nail withdrawal and lateral load capability are not included as they are covered by Test Methods **D1761**.

1.2 The tests described are as follows:

	Section
Dimensional tests	5
Tension test	6
Conventional bend test	7
Impact bend test	8
Rockwell hardness test	9
Coating weight test	10
Coating adherence test for zinc-coated nails	11

1.3 The values stated in inch-pound units are to be regarded as standard. The values given in parentheses are mathematical conversions to SI units that are provided for information only and are not considered standard.

1.4 *This standard does not purport to address all of the safety concerns, if any, associated with its use. It is the responsibility of the user of this standard to establish appropriate safety, health, and environmental practices and determine the applicability of regulatory limitations prior to use.*

1.5 *This international standard was developed in accordance with internationally recognized principles on standardization established in the Decision on Principles for the Development of International Standards, Guides and Recommendations issued by the World Trade Organization Technical Barriers to Trade (TBT) Committee.*

## 2. Referenced Documents

2.1 *ASTM Standards:*<sup>2</sup>

<sup>1</sup> These test methods are under the jurisdiction of ASTM Committee F16 on Fasteners and are the direct responsibilities of Subcommittee F16.05 on Driven and Other Fasteners.

Current edition approved Dec. 15, 2020. Published January 2021. Originally approved in 1980. Last previous edition approved in 2017 as F680-17. DOI: 10.1520/F0680-20.

<sup>2</sup> For referenced ASTM standards, visit the ASTM website, www.astm.org, or contact ASTM Customer Service at service@astm.org. For *Annual Book of ASTM Standards* volume information, refer to the standard's Document Summary page on the ASTM website.

- [A90/A90M Test Method for Weight \[Mass\] of Coating on Iron and Steel Articles with Zinc or Zinc-Alloy Coatings](#)
- [A370 Test Methods and Definitions for Mechanical Testing of Steel Products](#)
- [A428/A428M Test Method for Weight \[Mass\] of Coating on Aluminum-Coated Iron or Steel Articles](#)
- [D1761 Test Methods for Mechanical Fasteners in Wood and Wood-Based Materials](#)
- [E18 Test Methods for Rockwell Hardness of Metallic Materials](#)
- [F547 Terminology of Nails for Use with Wood and Wood-Base Materials](#)

## 3. Terminology

3.1 *Definitions*—For definitions of terms used in this test method, refer to Terminology **F547**.

## 4. Significance and Use

4.1 When specified, the tests selected for application shall be performed to assure conformance with requirements stipulated in the product specification.

## 5. Dimensional Tests

5.1 Dimensions to be evaluated include, but shall not be limited to length, shank diameter, diameter or major dimensions of head, straightness, head concentricity to shank, and length of point. For mechanically deformed nails, angle, depth, and configuration of deformations and other dimensional characteristics shall be measured when required. Unless specified, any suitable measuring means as identified in these test methods may be applied.

5.2 *Measurement of smooth shank nails:*

5.2.1 Smooth shank nails shall be measured at the approximated mid-point of the shank length. Additional locations along the shank may be selected as required.

5.2.2 Measurements shall not be taken across the gripper marks.

5.2.3 Average of two measurements taken approximately 90° apart shall constitute the diameter measurement.

5.3 Measurement of deformed shank nails diameters (See **Note 1**.)

5.3.1 For deformed shank nails where the deformation exists along the entire length of the shank.

\*A Summary of Changes section appears at the end of this standard

5.3.1.1 Measure at the approximate mid-point of the shank length. Additional locations along the shank may be selected as required.

5.3.1.2 Average of two measurements taken approximately 90° apart shall constitute the diameter measurement.

5.3.1.3 These measurements will only provide a crest diameter. Analysis of crest diameter increase versus nail diameter is not possible for this type of nail.

5.3.2 For deformed shank nails where the deformation does not extend along the entire length of the shank (Fig. 1).

5.3.2.1 Measure at the approximate mid-point of the deformed portion of the shank. Additional locations along the deformed shank portion may be selected as required, including at the top of the deformation (towards the head) and at the bottom of the deformation (towards the point) may also be appropriate.

5.3.2.2 When the difference between the crest diameter of the deformed section and the nail diameter is required (deformation growth), measurements shall also be taken across the smooth shank portion (see 5.2) and the deformed shank portion of the nail. The difference of the averages will determine deformation growth.

5.4 Preferred measuring devices in order of preference:

5.4.1 Handheld micrometer,

5.4.2 Handheld calipers, and

5.4.3 Optical measuring device such as comparator, shadow graph, etc. Optical devices will allow for the measurement of ring pitch (spacing between rings) and ring root diameters.

NOTE 1—The process of nail shank deformation results in an increase in diameter, or deformation growth across the crest diameter of the deformation.

## 6. Tension Test

6.1 Nails are not subject to tension testing. However, wire used to make the nails may be tested as required by prior agreement or to affect mill product control. The testing of wire is covered in the general section of Test Methods A370 and Supplement IV, Round Wire Products.

## 7. Conventional Bend Test

7.1 This test is used as a means of testing the ductility of certain types of nails or of the wires used in the manufacture of nails. The angle of bend and the mandrel diameter will be

specified in the product specification. The cold bending shall be performed by any hand or power device that will deform the sample closely about a mandrel of specified diameter through the required angle without causing damage to the nail surface. The sample shall be considered to have failed if fracture occurs prior to attainment of the required minimum bend angle. Unless otherwise specified, the conventional bend test shall not be applied to annularly threaded nails or to the region of a nail exhibiting gripper marks.

## 8. Impact Bend Test

8.1 The impact test is primarily applicable to the testing of pallet nails to assess their suitability for that application. The testing device is shown in Fig. 2 and its operation is described in Annex A1. For any given diameter, the data from this test can be correlated with Rockwell hardness used to specify the mechanical properties of the nail. The impact bend test is intended as a convenient test that may be used in manufacturing and consumer quality monitoring of mechanical properties. However, in the case of dispute, the Rockwell hardness test, supplemented by the conventional bend test, will be considered the governing test.

## 9. Rockwell Hardness Test

9.1 This test is used to measure the hardness of heat-treated nails. Prepare flat surfaces by grinding or filing. Take care not to alter the tempered hardness of the nail during preparation of the flats. The width of the prepared flat shall be sufficient to prevent edge bulge adjacent to each hardness impression. The thickness at the test section shall be sufficient to avoid a bulge or other visible markings on the surface opposite to the impression. Hardness can be determined using a shank having prepared parallel surfaces. Determine the hardness in accordance with Test Methods E18. Usually three readings are made on a nail and these readings are averaged for the final result.

9.2 An alternate method for determining Rockwell hardness is to cut the nail off about ½ in. (13 mm) from the head. Grind the top of the head to remove scale and obtain a flat surface. Grind the transversely cut end flat, using proper precautions not to alter the tempered hardness of the nail. Place the sample head down on the anvil of the hardness testing machine and determine the hardness on the transverse section.

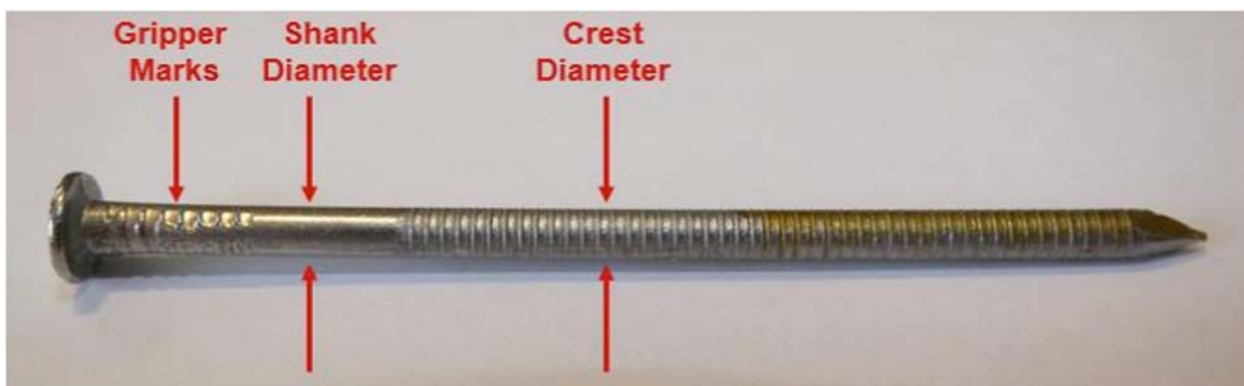
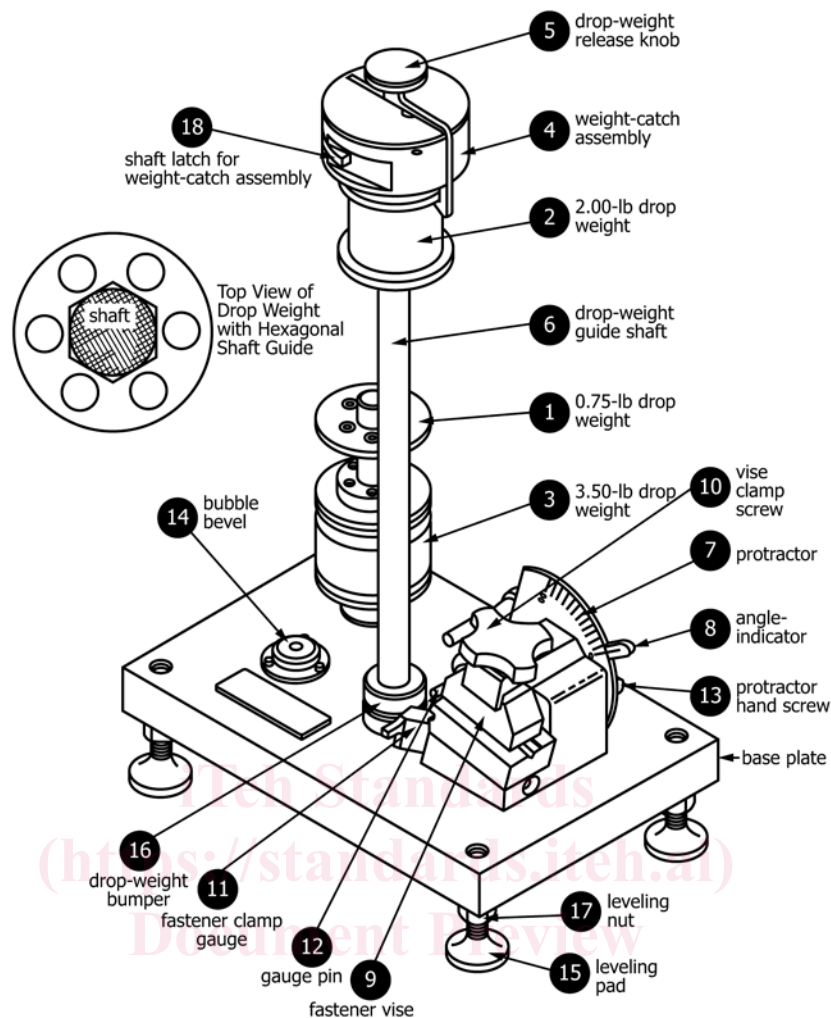

FIG. 1 Diameter Properties of a Ring Shank Nail



NOTE 1—This device is available from The National Wooden Pallet and Container Assn., 1625 Massachusetts Ave., Washington, DC 20036

FIG. 2 A Typical Impact Bend Tester for the Impact Bend Testing of Nails

## 10. Coating Weight Test

10.1 This test deals with zinc, aluminum, and copper-clad coatings only and does not deal with other metallic coatings such as cadmium.

10.2 Cut the heads and points from samples of zinc-coated or aluminum-coated nails selected for testing. Take a sufficient number of such specimens to provide a total length over 12 in. (300 mm), preferably about 24 in. (600 mm). Since the density of the steel is known (0.2836 lb/in.<sup>3</sup> (0.1276 kg/m<sup>3</sup>)), it is not necessary to use a specific total length of specimens.

10.3 Determine the weight of zinc coating in accordance with Test Method [A90/A90M](#).

10.4 Determine the weight of aluminum coating in accordance with Test Method [A428/A428M](#).

10.5 Determine the thickness of coating of copper-clad nails by one of the following three methods:

10.5.1 Accurately measuring the diameter of the wire before and after removing the cladding by any suitable means.

10.5.2 Cutting off the wire, grinding one end smooth, etching the exposed cross section to differentiate between core and cladding, and measuring under suitable magnification.

10.5.3 Using electrical indicating instruments.

10.6 Calculate the weight of the copper cladding from the thickness as measured above or determine the weight of the cladding by chemically stripping the copper and accurately weighing the wire sample before and after stripping.

## 11. Coating Adherence Test for Zinc-Coated Nails

11.1 Determine the adherence of the zinc coating to the surface of the base metal by cutting or prying with the point of a stout knife, applied with considerable pressure in a manner tending to remove a portion of the coating. The adherence shall be considered inadequate if the coating flakes off in the form of a layer or skin so as to expose the base metal in advance of the knife point. Testing carried out at edges or corners (points of lowest coating adherence) shall not be used to determine

adherence of coating. Likewise, removal of small particles of the coating by paring or whittling shall not be used to determine failure.

**12. Precision and Bias**

12.1 The precision and bias of these tests have not been determined at this time.

**ANNEXES**

**(Mandatory Information)**

**A1. OPERATION OF THE IMPACT BEND TESTER (FIG. NO. 1)**

A1.1 *Scope*—The test is applicable to nails with shank diameters of 0.106 in. (2.7 mm) to 0.135 in. (3.4 mm) and lengths of 1½ in. (38 mm) to 3 in. (76 mm) and with or without deformations.

A1.2 Hold the nail to be tested in a chuck in such a way that it cantilevers 15/32 in. (12 mm) at an angle of 80° to the vertical. Hit its head after the free-fall drop of a 3.50-lb (1.58-kg) weight from a 157/16 in. (392 mm) height, thereby applying 54.0 in.·lbf (6.1-J potential or 4.52-J kinetic) energy to the head of the inclined nail. As a result of this impacting, soft nails are bent readily without breaking and non-ductile nails fail abruptly partially or completely while being bent only a few degrees. The test includes recording the bend angle of the tested nail as well as the number and type of failure, if any.

A1.3 The impact bend test device, shown in Fig. 2, shall consist of a 0.750-in. (19.0-mm) diameter shaft, along which the 3.50-lb (1.58-kg) drop weight slides to hit the head of the nail. A protractor shall be used to measure the angle of the tested nail.

A1.4 Measure the dimensions of the nails prior to testing. Replace chuck inserts with worn edges with new ones. Position the specimen properly between the chuck inserts in such a way that the specimen protrudes 15/32 in. (12 mm) from the inserts. Tighten the chuck securely, to prevent the displacement of the nail during application of the impact load, and release the drop weight. Record the type of failure, if any, and the bend angle for each nail and determine the average bend angle for the nails tested.

ASTM F680-20

<https://standards.iteh.ai/catalog/standards/sist/79597249-2b3a-4916-ad7c-ccc749a8be5c/astm-f680-20>

**A2. NAIL SHANK DIAMETER (HANDHELD) MEASUREMENTS (Fig. A2.1–Fig. A2.5)**

A2.1 *Scope*—The techniques are applicable to nails with smooth or deformed shanks. This annex addresses only measurements with handheld devices.

A2.2 *Measurement of nail shanks with micrometers:*

A2.2.1 Micrometers shall have flat ends on the anvil and spindle.

A2.2.2 Open spindle of micrometer and place nail between anvil and spindle. (Fig. A2.1 and Fig. A2.2) gently turn the spindle to bring the measuring surfaces into contact with the



**FIG. A2.1 Proper Method Of Measuring**