



Designation: E127 – 20

Standard Practice for Fabrication and Control of Flat Bottomed Hole Ultrasonic Standard Reference Blocks¹

This standard is issued under the fixed designation E127; the number immediately following the designation indicates the year of original adoption or, in the case of revision, the year of last revision. A number in parentheses indicates the year of last reapproval. A superscript epsilon (ϵ) indicates an editorial change since the last revision or reapproval.

This standard has been approved for use by agencies of the U.S. Department of Defense.

1. Scope*

1.1 This practice covers a procedure for fabrication and control of metal alloy reference blocks used in ultrasonic examinations that contain flat bottom holes (FBH).

1.2 These blocks may be used for checking the performance of ultrasonic examination instrumentation and search units and for standardization and control of ultrasonic examination of metal alloy products.

1.3 The reference blocks described are suitable for use with either the direct-contact method or immersion pulse-echo ultrasonic methods.

1.4 Standard sets are described for flat surface sound entry; the Basic set, Area-Amplitude set, and Distance Amplitude set.

1.5 The requirements for FBH fabrication may be applied to round bar/billet reference standards and reference standards fabricated from other product forms.

1.6 This practice does not specify reference reflector sizes or product rejection limits. It does describe fabrication practices and applied tolerances. In all cases of conflict between this practice and customer specifications, the customer specification shall prevail.

1.7 The values stated in inch-pound units are to be regarded as standard. The values given in parentheses are mathematical conversions to SI units that are provided for information only and are not considered standard.

1.8 This practice has incorporated the requirements of Practice E428 and Guide E1158. Reference standards that were manufactured under Practice E428 and Guide E1158 comply with the requirements of this practice.

1.9 *This standard does not purport to address all of the safety concerns, if any, associated with its use. It is the responsibility of the user of this standard to establish appropriate*

safe safety, health, and environmental practices and determine the applicability of regulatory limitations prior to use.

1.10 *This international standard was developed in accordance with internationally recognized principles on standardization established in the Decision on Principles for the Development of International Standards, Guides and Recommendations issued by the World Trade Organization Technical Barriers to Trade (TBT) Committee.*

2. Referenced Documents

2.1 ASTM Standards:²

- B107/B107M Specification for Magnesium-Alloy Extruded Bars, Rods, Profiles, Tubes, and Wire
- B221 Specification for Aluminum and Aluminum-Alloy Extruded Bars, Rods, Wire, Profiles, and Tubes
- B241/B241M Specification for Aluminum and Aluminum-Alloy Seamless Pipe and Seamless Extruded Tube
- E317 Practice for Evaluating Performance Characteristics of Ultrasonic Pulse-Echo Testing Instruments and Systems without the Use of Electronic Measurement Instruments
- E428 Practice for Fabrication and Control of Metal, Other than Aluminum, Reference Blocks Used in Ultrasonic Testing (Withdrawn 2019)³
- E1065 Practice for Evaluating Characteristics of Ultrasonic Search Units
- E1158 Guide for Material Selection and Fabrication of Reference Blocks for the Pulsed Longitudinal Wave Ultrasonic Testing of Metal and Metal Alloy Production Material (Withdrawn 2019)³
- E1316 Terminology for Nondestructive Examinations
- E1324 Guide for Measuring Some Electronic Characteristics of Ultrasonic Testing Instruments
- E2375 Practice for Ultrasonic Testing of Wrought Products

¹ This practice is under the jurisdiction of ASTM Committee E07 on Nondestructive Testing and is the direct responsibility of Subcommittee E07.06 on Ultrasonic Method.

Current edition approved Dec. 1, 2020. Published January 2021. Originally approved in 1958. Last previous edition approved in 2019 as E127 – 19^ε1. DOI: 10.1520/E0127-20.

² For referenced ASTM standards, visit the ASTM website, www.astm.org, or contact ASTM Customer Service at service@astm.org. For *Annual Book of ASTM Standards* volume information, refer to the standard's Document Summary page on the ASTM website.

³ The last approved version of this historical standard is referenced on www.astm.org.

*A Summary of Changes section appears at the end of this standard

2.2 SAE Standards:⁴

AMS 4928 Titanium Alloy Bars, Wire, Forgings, and Rings
6Al - 4V Annealed

AMS 6409 Steel, Bars, Forgings, and Tubing 0.80Cr - 1.8Ni
- 0.25Mo (0.38 - 0.43C) (SAE 4340) Special Aircraft
Quality Cleanliness, Normalized and Tempered

AMS 6415 Steel, Bars, Forgings, and Tubing 0.80Cr - 1.8Ni
- 0.25Mo (0.38 - 0.43C) (SAE 4340)

AMS 6484 Steel, Bars, Forgings, and Tubing 0.80Cr - 1.8Ni
- 0.25Mo (0.38 - 0.43C) (SAE 4340) Normalized and
Tempered

QQ-A225/6 Aluminum Alloy, 2024, Bar, Rod, and Wire;
Rolled, Drawn, or Cold Finished

QQ-A225/9 Aluminum Alloy 7075, Bar, Rod, Wire, and
Special Shapes; Rolled, Drawn, or Cold Finished

3. Terminology

3.1 Definitions—For definitions of terms not specific to this practice, refer to Terminology E1316.

3.2 Definitions of Terms Specific to This Standard:

3.2.1 angular error, *n*—the condition observed in ultrasonic tests of reference blocks when the response from the hole bottom is not maximum while the search unit is positioned to

obtain either a maximum number of back reflections from a reference block or a maximum indication from its entry surface.

3.2.1.1 Discussion—Angular error results when the entry surface, hole bottom, and back surface are not parallel to each other.

3.2.2 entry surface, *n*—the end of a reference block through which ultrasonic energy must pass when reflections from the hole bottom are obtained.

3.2.3 hole bottom, *n*—the flat reflecting surface in a reference block that is obtained by making the entire end of a drilled hole smooth and flat using best machining practices; the hole bottom is parallel to the entry surface of the block.

3.2.4 hole size, *n*—the diameter of the hole in a reference block that determines the area of the hole bottom.

3.2.5 metal distance, *n*—the distance in a reference block from its entry surface to the hole bottom.

3.2.6 non-standard blocks, *n*—blocks fabricated from production material shapes, round and flat bar and billet, concave surface standards, extruded, forged and additive manufactured shapes.

3.2.7 standard block sets, *n*—flat entry surface blocks fabricated per Fig. 1.

⁴ Available from SAE International (SAE), 400 Commonwealth Dr., Warrendale, PA 15096, <http://www.sae.org>.

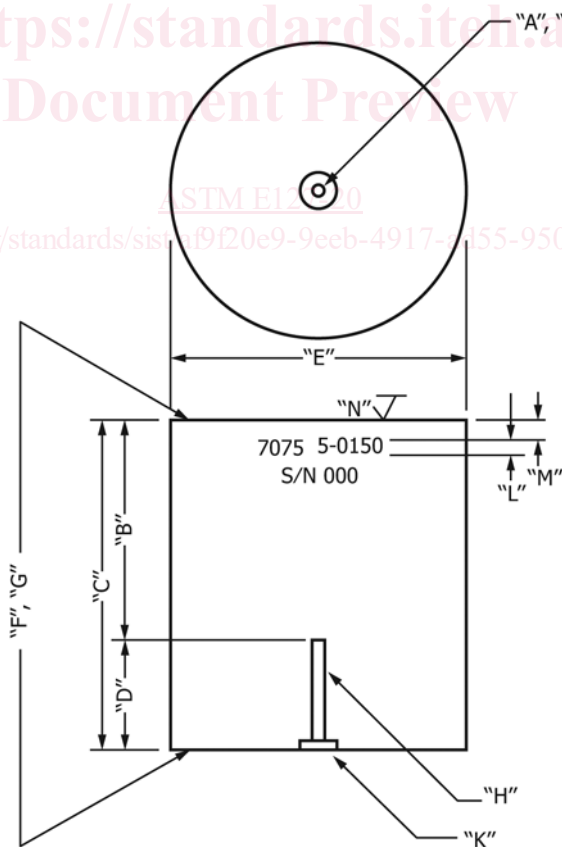

FIG. 1 Standard Set Block Dimensions

3.2.7.1 *Discussion*—Recommended Area Amplitude, Distance Amplitude, and Basic sets of these blocks are described in Section 6.

4. Summary of Practice

4.1 Standard Sets (See 3.2.7)

4.1.1 These recommended sets are described in Section 6. Reference standard material is ultrasonically evaluated to ensure freedom from significant discontinuities and is then precisely fabricated into cylindrical blocks of prescribed lengths. A single, flat-bottom hole of specific diameter is drilled to a constant depth into the end of each block at its center, and the blocks are grouped into sets according to hole size and block length, or metal distance.

4.1.2 Each block is checked ultrasonically using a calibrated ultrasonic test system at a prescribed test frequency. Distance-amplitude and area-amplitude characteristics are established for sets of fabricated blocks using specific reflectors to provide a standard response. Curves are plotted to establish the interrelationship between the various blocks in the sets.

4.2 Non-Standard Blocks (See 3.2.6)

4.2.1 Reference standard material is ultrasonically evaluated to ensure freedom from significant discontinuities. The entry surface shall be free of surface discontinuities that would interfere with the sound beam.

4.2.2 Due to the variability of the end user test conditions, the curves plotting the interrelationship between the FBHs in the standard are typically performed by the end user, not the fabricator.

4.3 Selection of Material

4.3.1 Section 7 of this standard contains guidance on the selection and testing of material for ultrasonic reference standards.

5. Significance and Use

5.1 Standard reference block sets per 4.1 fabricated in accordance with this practice will exhibit specific area-amplitude and distance amplitude relationships only with an immersion test at 5 MHz using the search unit, test instrument, and test parameters described in this practice. Comparison tests at other frequencies or with uncalibrated instruments will not necessarily give the same relationships shown in this practice. See Ref (1)⁵ for area-amplitude limitations at other frequencies and transducer diameters. Also see Ref (2) for cautions regarding use of standard blocks for test standardizations.

5.2 Reference standards fabricated per 4.2 may utilize the fabrication and verification techniques herein. Due to the variable nature of non-standard blocks, the details should be agreed upon in the ordering documents.

6. Description of Various Recommended Sets

6.1 In ultrasonic testing of metals, a standard reference usually is necessary to establish a specified test sensitivity. A standard ultrasonic reference also is required frequently to

⁵ The boldface numbers in parentheses refer to a list of references at the end of this standard.

determine the effect of variations in metal distance upon the ultrasonic response from detected discontinuities. Test sensitivity standardizations and corrections for metal distance are most reliable when made under the same conditions employed for the actual tests. For these purposes, reference blocks containing various combinations of hole size and metal distance are necessary.

6.2 The following combinations or sets of blocks are recommended:

6.2.1 *Basic Set*—The basic set consisting of ten reference blocks is listed in Table 1. Area-amplitude relations are obtained by intercomparison of blocks containing the 3 in. (76.2 mm) metal distance and $\frac{3}{64}$ in., $\frac{5}{64}$ in., and $\frac{8}{64}$ in. (see Table 2 note) diameter holes, respectively. Distance-amplitude relations are obtained by intercomparison of the blocks of various lengths which contain $\frac{5}{64}$ in. diameter holes.

NOTE 1—Direct conversion from inches to millimetres (1 in. = 25.4 mm) gives hole size dimensions for which there are no standard metric drills; however, Table 2 gives the nearest standard metric drill size.

6.2.2 *Area-Amplitude Set*—The area-amplitude set consisting of eight ultrasonic standard reference blocks is listed in Table 3. Area-amplitude relationships are obtained by intercomparison of any three or more blocks with different flat bottom-hole sizes at the same metal distance from front surface to hole bottom.

6.2.3 *Distance-Amplitude Set*—A distance-amplitude set may include any convenient number of the reference blocks shown in Table 4 and does not necessarily include all blocks listed. A recommended distance-amplitude set contains at least 12 blocks, and each set contains only one of the three hole sizes shown in Table 4. Blocks comprising the 19 block distance-amplitude sets, which are customarily supplied commercially, are indicated in Table 4. Increments of metal distance in each of the three groups of blocks in the recommended set should be identical. Distance-amplitude relationships are obtained by intercomparison of all blocks containing the same size hole.

TABLE 1 Dimensions and Identification of Reference Blocks in the Basic Set (see Fig. 1)

NOTE 1—Direct conversion from inches to millimeters (1 in. = 25.4 mm) gives hole size dimensions for which there are no standard metric drills; however, Table 2 gives the nearest standard metric drill size.

Block Identification Number	Hole Diameter (A)		Metal Distance (B)		Overall Length (C)	
	$\frac{1}{64}$ ths in.	in.	in.	mm	in.	mm
3-0300	3	3.000	76.2	3.750	95.2	
5-0012	5	0.125	3.2	0.875	22.2	
5-0025	5	0.250	6.4	1.000	25.4	
5-0050	5	0.500	12.7	1.250	31.8	
5-0075	5	0.750	19.0	1.500	38.1	
5-0150	5	1.500	38.1	2.250	57.2	
5-0300	5	3.000	76.2	3.750	95.2	
5-0600	5	6.000	152.4	6.750	171.4	
8-0300	8	3.000	76.2	3.750	95.2	
8-0600	8	6.000	152.4	6.750	171.4	

TABLE 2 Diameter of Flat-Bottom Holes in Inch-Pound Units and the Nearest Metric Drill Hole Diameter

NOTE 1—Ratio of the area of the nearest metric drill size to the area of the inch-pound drill size is 1.016 throughout.

Hole Diameter in Inch-Pound Units, in.	Nearest Metric Drill Size, mm
1/64	0.40
2/64	0.80
3/64	1.20
4/64	1.60
5/64	2.00
6/64	2.40
7/64	2.80
8/64	3.20

TABLE 4 Dimensions and Identification of Reference Blocks in Distance-Amplitude Sets

Block Identification Number, 3-, 5-, and 8- ^A	Metal Distance (B)		Overall Length (C)	
	in.	mm	in.	mm
-0006 ^B	0.0625	1.6	0.812	20.6
-0012 ^B	0.125	3.2	0.875	22.2
-0025 ^B	0.250	6.4	1.000	25.4
-0038 ^B	0.375	9.5	1.125	28.6
-0050 ^B	0.500	12.7	1.250	31.8
-0062 ^B	0.625	15.9	1.375	34.9
-0075 ^B	0.750	19.1	1.500	38.1
-0088 ^B	0.875	22.2	1.625	41.3
-0100 ^B	1.000	25.4	1.750	44.5
-0125 ^B	1.250	31.8	2.000	50.8
-0150	1.500	38.1	2.250	57.2
-0175 ^B	1.750	44.5	2.500	63.5
-0200	2.000	50.8	2.750	69.9
-0225 ^B	2.250	57.2	3.000	76.2
-0250	2.500	63.5	3.250	82.6
-0275 ^B	2.750	69.9	3.500	88.9
-0300	3.000	76.2	3.750	95.3
-0325 ^B	3.250	82.6	4.000	101.6
-0350	3.500	88.9	4.250	108.0
-0375 ^B	3.750	95.3	4.500	114.3
-0400	4.000	101.6	4.750	120.7
-0425 ^B	4.250	108.0	5.000	127.0
-0450	4.500	114.3	5.250	133.4
-0475 ^B	4.750	120.7	5.500	139.7
-0500	5.000	127.0	5.750	146.1
-0525 ^B	5.250	133.4	6.000	152.4
-0550	5.500	139.7	6.250	158.8
-0575 ^B	5.750	146.1	6.500	165.1
-0600	6.000	152.4	6.750	171.5

^A Hole diameters (A) 3/64, 5/64, and 8/64 in.

^B Blocks customarily included in commercial 19 block distance-amplitude sets.

TABLE 3 Dimensions and Identification of Reference Blocks in the Area-Amplitude Set (see Fig. 1)

Block Identification Number	Hole Diameter (A)		Metal Distance (B)		Overall Length (C)	
	1/64 ths in.	in.	mm	in.	mm	
1-0300	1	3.000	76.2	3.750	95.3	
2-0300	2	3.000	76.2	3.750	95.3	
3-0300	3	3.000	76.2	3.750	95.3	
4-0300	4	3.000	76.2	3.750	95.3	
5-0300	5	3.000	76.2	3.750	95.3	
6-0300	6	3.000	76.2	3.750	95.3	
7-0300	7	3.000	76.2	3.750	95.3	
8-0300	8	3.000	76.2	3.750	95.3	

6.3 If the blocks are to be used for immersion testing, they should be suitably anodized or otherwise protected to enhance resistance to corrosion. Uncoated blocks shall be designated as Type 1; coated blocks shall be designated as Type 2.

6.4 A number of important variables that affect the response from reference blocks can be controlled during fabrication by accurate machining practices. The roughness of the entry surface; the alignment of entry surface, hole bottom, and back surface; and the surface condition of the hole bottom are the more important physical variables that must be controlled during the fabrication of reference blocks. The quality of material used for blocks also is a factor.

6.5 *Non-Standard Blocks*—There are many different types of reference blocks used in industry depending upon the size and shape of the material to be examined. Some of the more common flat bottom hole (FBH) types are described in [Appendix X2](#).

7. Material Selection

7.1 Recommended materials for standard block sets are listed in [Table 5](#) (Practice [E2375](#)).

7.2 For non-standard blocks, it is good practice to use a sample removed from the production lot of material as the reference block material. When this is not possible the reference block material should be of the same general shape and dimensions, surface finish, chemical composition, and microstructure as the production material to be examined.

7.3 To ensure that the material chosen is suitable for use as reference block material and is free of potentially interfering

TABLE 5 Recommended Reference Block Material

Material to be Tested	Reference Material	Typical Specification
Aluminum	7075-T6	ASTM B221 , ASTM B241/B241M , QQ-A225/9
---	2024	ASTM B221 , ASTM B241/B241M , QQ-A225/6
Magnesium	ZK60	ASTM B107/B107M
Titanium	Ti-6Al-4V annealed	AMS 4928
Low Alloy Steels	4340 annealed	AMS 6484, AMS 6415, AMS 6409

reflectors, ultrasonically examine the reference block material at the anticipated frequency and at a sensitivity that produces an acoustic noise level of 20 % screen height. The entire block should be scanned from the surface which will be used for standardization. Any discrete indication that exceeds 40 % screen height should be cause to remove the material from consideration as an ultrasonic reference block.

7.3.1 For materials with very low noise levels, this test may be over-sensitive. Such materials may be ultrasonically examined at a sensitivity that assures no signals will be present in the material that is more than half the response of the intended flat bottomed hole response. Suitable reference standards in acoustically similar material will be required for standardization of the test.

7.4 Methods for determining acoustic compatibility of reference standards and material under test are typically defined by the governing ultrasonic test specification.

8. Fabrication Procedure

8.1 Standard sets per 4.1 shall be fabricated to the dimensions of Fig. 1 and Table 6.

8.2 The following machining sequence is recommended:

8.2.1 Machine all blocks to a uniform entry surface finish and to the required dimensional tolerances.

8.2.2 Drill the test hole to the nominal depth with a standard drill point.

8.2.3 Carefully prepare a flat-bottom drill or cutter with cutting edges square and flat within 0.0005 in. (0.013 mm) and perpendicular to its longitudinal axis (flatness, squareness, etc., should be checked at a minimum of 60× magnification on an optical comparator).

8.2.4 Continue to drill as needed to remove all the conical configuration of the bottom of the hole

8.2.5 Remove drill, check cutting edge, regrind, if necessary.

8.2.6 Remove an additional 0.005 in. (0.13 mm) of material from the hole bottom.

8.2.7 Recheck cutting edges of the drill on the optical comparator, regrind, if necessary, and repeat 8.2.5 and 8.2.6. Careful attention must be given to the squareness of corners of the cutter; the slightest radius reduces the reflective area of the hole bottom.

8.2.8 *Typical Block Identification:*

7075 = Typical alloy designation,

5 = Hole size in 1/64 in. increments, and

0150 = 1.50 in. metal travel in 00.00 in.

8.3 *Non-standard Blocks*, fabricated from production shapes, bar/billet standards, curved surface standards, etc. will use the fabrication methods of 8.2 and the tolerances defined in Table 6 as far as is practical. Surface finish on bar and billet standards is typically the finish supplied on the bar or as specified by the customer. For blocks such as concave standards where the surface is fabricated, the surface finish tolerance of Table 6 may be applicable. Metal distance is typically defined by governing Ultrasonic Method Specifications or as specified by the customer.

8.4 *Counterbore Method for Deep Flat Bottomed Holes*—This describes a method for fabricating deep FBHs that can be simpler, faster, and less expensive than those used to fabricate

the blocks shown in to Figs. X2.2-X2.5. A pilot hole is used to locate and position the FBH thus eliminating the milling of the steps. This allows the bar circumference to remain for support during standardization which is much more representative to production material. This method also results in an added advantage for mechanical examination of rotating material by allowing signals from the reference block to be more easily evaluated dynamically as the block is moved at the maximum scanning rate.

8.4.1 The method is simply to use a larger pilot drill to produce a hole to within a short distance of the depth of the FBH. The body and bottoming drills for the FBH are then successively mounted in a holder of the same diameter as the pilot drill for the final drilling and flattening operations. This helps to ensure that the flat bottom of the final hole will be parallel to a tangent of the top surface at a point immediately above the hole. This is due to the increased stiffness of the pilot drill and the holder being much greater than that of the smaller final drills. That prevents skewing of the final holes that could result from deep drilling of a small hole due to excess drilling speed or pressure or to grain anomalies or small hardness variations in the material that might deflect smaller drills if used for the total distance.

8.4.2 The size of a typical pilot hole used for this purpose is 0.375 in. (9.53 mm). The pilot hole is typically drilled to within approximately 0.50 in. (12.7 mm) of the final desired FBH depth. After the FBH is drilled, cleaned, and verified the entrance to the pilot hole must be sealed to prevent the entry of couplant or other foreign material.

8.4.3 Fig. X2.1 shows cross sectional views of FBHs placed in a round bar by this method.

8.4.4 For standardization of a system for examination of cylindrical material, the bottom of the FBH fabricated in accordance with this procedure at any depth in the material may be used for “static” standardization (that is, with no relative motion between standard and search unit). “Dynamic” standardization is performed with rotary and translational motion between standard and search unit at the maximum speeds to be used for the final examination. In this case, the instrument alarm gate may be set to be activated by the signal from any FBH drilled to a depth of less than a radius of the material while not responding to signals from the sides of the

TABLE 6 Fabrication Tolerances for Standard Set Blocks

Parameter	Dimension	Tolerance	Dimension Metric (mm)	Tolerance Metric (mm)
A. FBH Diameter	Per Table 1, Table 3	±0.0005 in.	Per Table 1, Table 3	±0,0127
B. Metal Distance	Per Table 1, Table 3, Table 4	±0.015 in.	Per Table 1, Table 3, Table 4	±0,381
C. Overall Length	Per Table 1, Table 3, Table 4	±0.005 in.	Per Table 1, Table 3, Table 4	±0,127
D. Hole Depth	0.75 in.	±0.005 in.	19,05	±0,127
E. Block Diameter	2.0 in.	±0.020 in.	50,8	±0,508
Block Diameter >6 in. TMD	2.5 in.	±0.030 in.	63,5	±0,762
F. End Face Flatness	Within 0.0005 in.	---	Within 0,0127	---
G. Parallelism	Within 0.001 in.	---	Within 0,0254	---
H. FBH Perpendicularity	Within 20 minutes	---	Within 20 minutes	---
I. Hole Bottom Flatness	0.001 in.	Per 0.125 in.	0.0254	Per 3,175
J. Centered	Within 0.010 in.	---	Within 0,254	---
K. Counterbore	0.25 in. x 0.063 in.	---	6,35 x 1,6	---
L. Block ID Size	0.12 in.	min height	3,048	min height
M. Block ID Location	0.25 in.	min from top	6,35	min from top
N. Entry Surface Finish	32 μinch	max	0,8 μmeter	max
Other Surface Finish	63 μinch	nominal	1,6 μmeter	nominal

pilot or FBH drills as they enter the beam from the search unit. For C-scan standardization, all FBH depths can be gated at once, the pilot holes show up separate from the FBH indications.

8.5 Diffusion Bonding Method—The diffusion bonding technique offers an alternative method of reference block manufacture. With this method, it is possible to fabricate reference blocks containing flat disc-shaped ultrasonic reflectors instead of FBHs. In many cases, this permits the examination of the reference block from more than one direction, thus enhancing the utility of the block.

8.5.1 A typical example is shown in **Fig. X2.6** in **Appendix X2**. A diffusion-bonded reference block for small diameter rounds could be fabricated as shown. A section is removed from one of the round bars to be examined. The bar section is split lengthwise and both split surfaces are carefully ground. An end mill of the desired diameter is used to mill a shallow (typically $\frac{1}{2}$ the hole diameter in depth) FBH in one of the split sections. The sections are then bonded back together using the diffusion bonding process. (The application of heat and pressure on the two sections for a period of time results in a sound diffusion bond which is indistinguishable ultrasonically from the normal structure.) (See **Note 2**.) The result is a reference standard that can be examined from either of two sides.

NOTE 2—The time, temperature, and pressure requirements for a diffusion bond are both material and configuration dependent and therefore are beyond the scope of this practice. The American Welding Society can furnish information on the subject.

8.5.2 With developed skills, all of the reference blocks shown in **Figs. X2.1-X2.5** along with many more types can be successfully fabricated using the diffusion bonding technique.

8.5.3 Replication of the disc-shaped reflector in diffusion bonded reference blocks is not possible. An alternative method of determining whether the reflector has been distorted by the bonding process is to fabricate a second block under identical conditions for destructive examination at the conclusion of the process.

9. Checking Physical Characteristics

9.1 All dimensions of the reference blocks including the diameter and perpendicularity of the examination hole may be checked by normal quality control procedures for physical measurements. The configuration, squareness, flatness, and surface finish for hole bottoms $\frac{3}{64}$ in. (1.2 mm) in diameter and larger may be checked by the following recommended technique for making and evaluating plastic replicas:

9.1.1 Clean hole with a suitable oil-free noncorrosive solvent and dry with a stream of dried and filtered air.

9.1.2 Mix the replicating material in accordance with the manufacturer's instructions.

9.1.3 Force the material into the hole with a disposable medical syringe and needle of adequate size.

9.1.4 Fill the hole beginning at the bottom and gradually moving outward making certain that no air pockets or bubbles remain in the hole.

9.1.5 Insert a small wire, pin, needle, or other suitable object that will serve as a rigid core and facilitate removal of the replica.

9.1.6 After curing, the replica may be removed and examined. The replica shall indicate that the hole diameter and hole bottom flatness are within **Table 6** tolerances and hole bottom roughness shall not be greater than 16 μ inch Ra finish. For record purposes, the replica may be projected on a comparator screen and photographed as shown in **Fig. 2**, or other equivalent techniques.

10. Procedure for Assessing Ultrasonic Characteristics of Blocks

10.1 For standard block sets, all measurements of area/amplitude and distance amplitude characteristics are to be made using a 5 MHz, $\frac{3}{8}$ in. (9.5 mm) flat transducer at a water path distance equal to the measured distance to the last near-field maximum (Y0+) and a calibrated test instrument. The transducer shall be characterized according to **Practice E1065**. Reference blocks that exhibit satisfactory external physical characteristics and proper configuration of the hole shall be subjected to additional examination to check their ultrasonic response characteristics. If the ultrasonic-response characteristics are to be established by immersion techniques, the drilled flat-bottom holes shall be cleaned and temporarily plugged or sealed by some other suitable technique to ensure a leak-tight closure. It is recommended that blocks fabricated as sets be compared with each other to determine their relative ultrasonic-response characteristics. This is particularly desirable in the cases of sets containing flat-bottom holes smaller than $\frac{3}{64}$ in. (1.2 mm) in diameter that cannot be satisfactorily replicated.

10.2 Area/Amplitude Response Curves—An area/amplitude set may contain several blocks with same external dimensions and distance from the entry surface to the selected FBHs of varying sizes. An area/amplitude-response curve may be obtained by recoding the gain setting required to set each block response to a set full screen height reference level (choosing a set value in the range of 50 % to 90 % is recommended). Relative area on the X axis is the block number squared (a #8 block is plotted as 64 relative area units.) The Relative Area X axis is plotted on a logarithmic scale. A typical area/amplitude curve for a set of blocks is shown in **Fig. 3**. Any block that exhibits an erratic ultrasonic response and does not fall within the apparent normal area/amplitude-response curve is considered unsatisfactory and shall not be used. Modification of the FBH to meet the required ultrasonic response is not an acceptable procedure. Area/amplitude responses between different FBH sizes are calculated by the formula

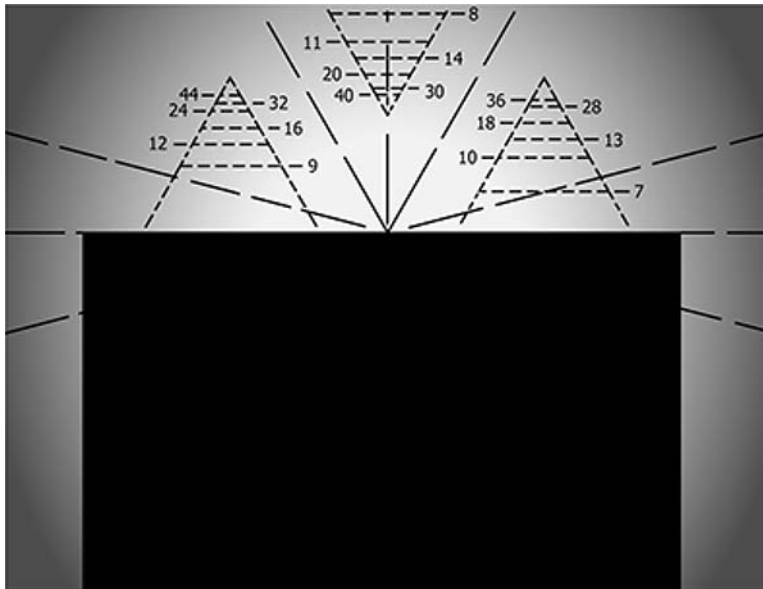

FIG. 2 Shadow-Graph (20x Magnification) of $\frac{1}{64}$ in. (6.4 mm) Diameter Flat-Bottom Hole Replica as Viewed on 62.5x Optical Comparator with Commercial Viewing Screen (Reduced $\frac{1}{2}$)

E127 Area Amplitude Plot, S/N #####
8 Block set, 4340 Steel

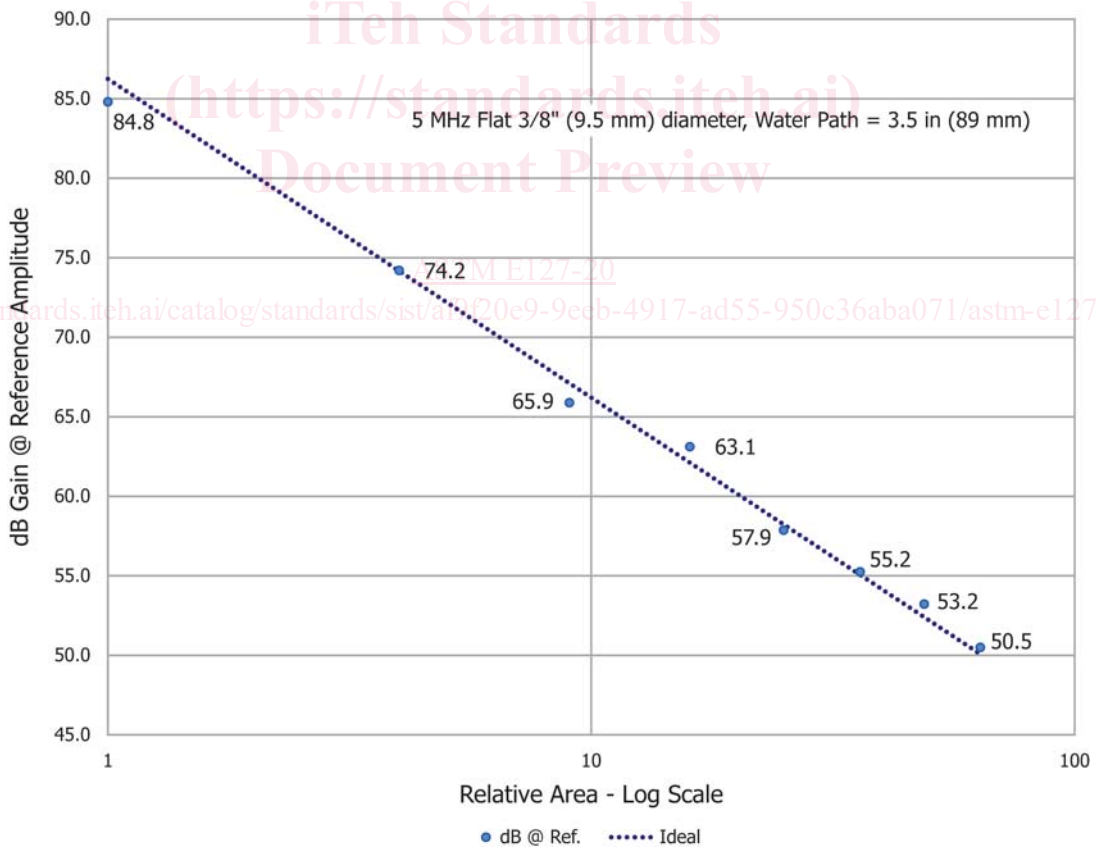

FIG. 3 Area Amplitude Response Plot

$dB=20*LOG(\frac{A1}{A2})$ where A1 and A2 are the areas of the flat bottomed holes. See S1 for additional ordering options.

10.3 Distance Amplitude Response Curves—A distance/amplitude set may contain a number of blocks with identical