



Designation: ~~C1889~~–19 ~~C1889~~ – 21

Standard Practice for Minimum Structural Design Loading for Monolithic or Sectional Precast Concrete Utility, Water, and Wastewater Structures Using AASHTO LRFD Design¹

This standard is issued under the fixed designation C1889; the number immediately following the designation indicates the year of original adoption or, in the case of revision, the year of last revision. A number in parentheses indicates the year of last reapproval. A superscript epsilon (ε) indicates an editorial change since the last revision or reapproval.

1. Scope

1.1 This practice describes the minimum loads to be applied when designing monolithic or sectional precast concrete utility structures, or sectional precast concrete water and wastewater structures, where AASHTO LRFD design is required. Concrete pipe, box culverts, and material covered in Specification ~~C478C478/C478M~~ are excluded from this practice. Structures not requiring AASHTO LRFD design are to be designed using the loads specified in ASTM ~~C857~~ or ASTM ~~C890~~, as applicable.

1.2 The values stated in inch-pound units are to be regarded as the standard. The values given in parentheses are provided for information only.

1.3 *This standard does not purport to address all of the safety concerns, if any, associated with its use. It is the responsibility of the user of this standard to establish appropriate safety, health, and environmental practices and determine the applicability of regulatory limitations prior to use.*

1.4 *This international standard was developed in accordance with internationally recognized principles on standardization established in the Decision on Principles for the Development of International Standards, Guides and Recommendations issued by the World Trade Organization Technical Barriers to Trade (TBT) Committee.*

2. Referenced Documents

2.1 ASTM Standards:²

~~C478C478/C478M~~ Specification for Circular Precast Reinforced Concrete Manhole Sections (Metric) ~~C0478_C0478M~~
~~C857~~ Practice for Minimum Structural Design Loading for Underground Precast Concrete Utility Structures
~~C890~~ Practice for Minimum Structural Design Loading for Monolithic or Sectional Precast Concrete Water and Wastewater Structures

2.2 AASHTO Standard:³

~~AASHTO LRFD~~ Bridge Design Specifications (Current Edition)

3. Terminology

3.1 Definitions of Terms Specific to This Standard:

¹ This test method is under the jurisdiction of ASTM Committee C27 on Precast Concrete Products and is the direct responsibility of Subcommittee C27.30 on Water and Wastewater Containers.

Current edition approved Nov. 1, 2019/Jan. 1, 2021. Published December 2019/January 2021. Originally approved in 1919. Last previous edition approved in 1919 as C1889 - 19. DOI: 10.1520/C1889-19/10.1520/C1889-21

² For referenced ASTM standards, visit the ASTM website, www.astm.org, or contact ASTM Customer Service at service@astm.org. For *Annual Book of ASTM Standards* volume information, refer to the standard's Document Summary page on the ASTM website.

³ Available from American Association of State Highway and Transportation Officials (AASHTO), 444 N. Capitol St., NW, Suite 249, Washington, DC 20001, http://www.transportation.org.

- 3.1.1 *above ground structures, n*—all structures with their base above ground.
- 3.1.2 *bearing loads, n*—foundation pressure reaction to all loads acting on the structure.
- 3.1.3 *below ground structures, n*—all structures other than those with their base at or above ground.
- 3.1.4 *construction loads*—all loads superimposed on the structure due to equipment and vehicles related to the installation of the structure and subsequent construction activities in the vicinity of the structure.
- 3.1.5 *dead loads, n*—weight of the structure and all permanent loads imposed on the structure.
- 3.1.6 *dynamic load allowance (Impact)*—percentage increment to be added to the traffic load to account for wheel load impact from moving vehicles.
- 3.1.7 *equipment loads, n*—loads induced into the structure by equipment installed on mounting devices cast into the structure or mechanically and permanently attached to the structure.
- 3.1.8 *ground level, n*—ground surface elevation at the finished surface of the structure.
- 3.1.9 *height of the structure, n*—total height from outside bottom of the structure to the ground level.
- 3.1.10 *hydrostatic loads, n*—all pressures due to the weight of water or other liquids.
- 3.1.11 *KIP, n*—1000 lbf. (kilo pound)
- 3.1.12 *KSI, n*—KIPs per square inch.
- 3.1.13 *lane load*—a uniform load applied to a 10-foot-wide lane on a bridge deck where the span exceeds 15 feet.
- 3.1.14 *lateral earth loads, n*—all pressures due to the effective weight of adjacent earth backfill.
- 3.1.15 *lateral surcharge loads*—lateral pressure due to vertical loads superimposed on the adjacent earth backfill.
- 3.1.16 *lifting loads, n*—forces induced into the structure during handling at the precast plant and the construction site.
- 3.1.17 *live loads*—all loads superimposed on the structure or adjacent earth fill due to vehicles or pedestrians.
- 3.1.18 *Load and Resistance Factor Design (LRFD)*—a design philosophy used in the design of concrete structures that takes variability in the behavior of structural elements and loads into account.
- 3.1.19 *load modifier*—additional load factor to account for the ductility (n_D), redundancy (n_R), and the operational importance (n_I) of a bridge or other structure.
- 3.1.19.1 *Discussion*—
~~Buried structures are considered to be non-redundant under earth fill ($n_R = 1.05$), and redundant under live and dynamic load allowance loads ($n_R = 1.00$) according to AASHTO LRFD 1.3.4 and 12.5.4. Typical value of the operational importance classification for precast structures (n_I) is 1.00, but may be reduced to 0.95 when the structure is considered non-critical.~~
- 3.1.19 *multiple presence factor*—additional live load factor to account for the probability of simultaneous lane occupation by the full AASHTO HL-93 design live load.
- 3.1.20 *OD*—outside Dimension of a structure.

3.1.21 *utility structure*—a structure that is used by an electric, gas, communication or similar industries.

3.1.22 *water and wastewater structures*—solar heating reservoirs, septic tanks, cisterns, holding tanks, leaching tanks, extended aeration tanks, wet wells, pumping stations, grease traps, distribution boxes, oil-water separators, treatment plants, manure pits, catch basins, drop inlets, and similar structures.

4. Significance and Use

4.1 This practice is intended to standardize the minimum structural loads used to design a precast concrete product using AASHTO LRFD.

4.2 The user is cautioned to properly correlate the anticipated field conditions and requirements with the design loads. Field conditions may dictate loads greater than described here.

5. Design Loads

5.1 Vertical Loads:

5.1.1 Permanent vertical loads typically include the weight of the concrete structure, road bed, walkways, earth fill and access opening covers.

5.1.2 Minimum unit weights of materials for design, unless specified otherwise, shall be: 140 lb/ft³ for compacted aggregate or bituminous paving; 145 lb/ft³ for concrete (Compressive strength ≤ 5.0 KSI); 120 lb/ft³ for compacted soils.

NOTE 1—Unit weights are as shown in AASHTO LRFD Section 3.5.1, Table 1.

5.1.3 Earth fill loading on top of the structure shall be modified for soil-structure interaction by a value of W_e , per the following:

$$W_e = F_e * \gamma * H \quad (1)$$

where:

W_e = soil-structure interaction variable for unfactored earth load, lbf/ft²,

F_e = $1 + 0.20 \frac{H}{B_c}$ (not to exceed 1.15),

γ = unit weight of soil, lb/ft³ (120 lb/ft³ unless noted otherwise),

B_c = width of structure (OD), ft, and

H = height of fill between wheels (ground level) and structure, ft.

NOTE 2—Soil Structure interaction loads refer to AASHTO LRFD Section 12.11.2.2.

5.1.4 Traffic Loads:

5.1.5 The vehicle loading arrangement, spacing, and weights of vehicle axles for an AASHTO HL-93 design truck are shown in Fig. 1, and the AASHTO Design Tandem axles are shown in Fig. 2.

NOTE 3—Vehicle loads per AASHTO LRFD Section 3.6.1.2.2.

5.1.6 For spans greater than 15 ft where the structure is subjected to direct traffic loads, a lane load shall be applied. The lane load shall consist of a 640 lbf/linear foot (in the travel direction) live load, transversely distributed over a width of 10 ft, but not subject to the dynamic load allowance.

5.1.7 For structures designed for a single truck, the multiple presence factor of 1.2 shall be applied. For structures where two (2) vehicles side by side are considered in the design, the multiple presence factor shall be 1.0.

5.1.8 Distribution of Wheel Loads at the Surface:

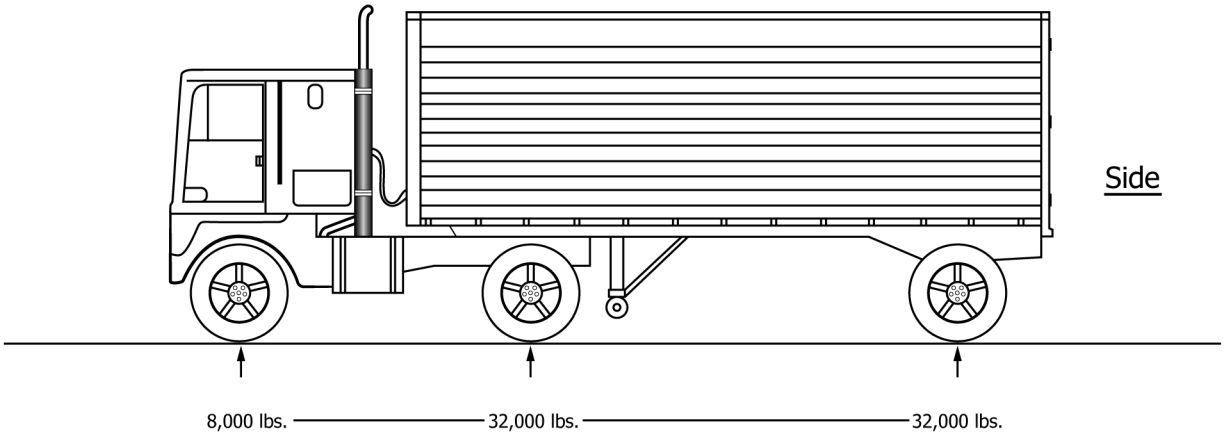

Tire Contact Area = 10" × 20"

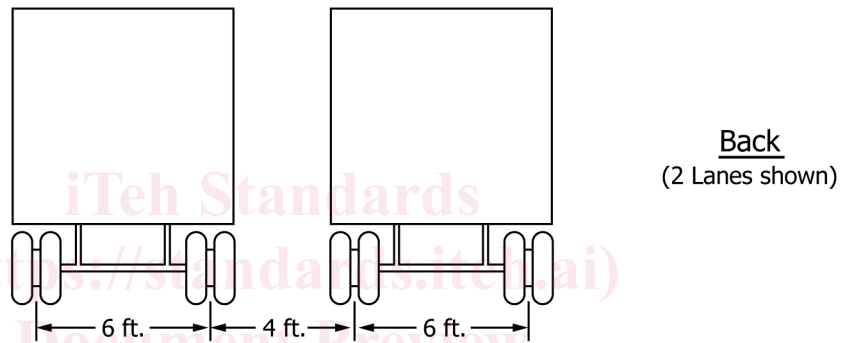

FIG. 1 Loading Arrangements (AASHTO HL-93)

ASTM C1889-21
<https://standards.iteh.ai/catalog/standards/sist/288c00070e-449c-b367-9cae03010ce2/astm-c1889-21>

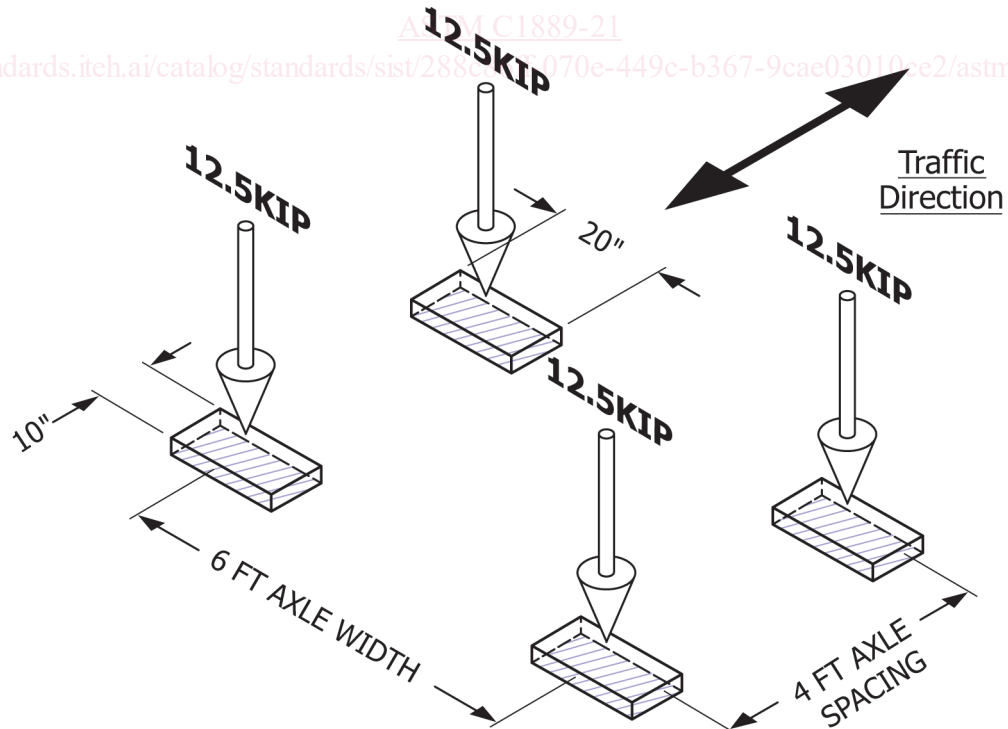

FIG. 2 Loading Arrangements (AASHTO Design Tandem Axles)

5.1.8.1 For structures where the depth of fill is less than 2.0 ft, concentrated live loads from a single traffic wheel, shall be distributed perpendicular to the span by an amount equal to E , the effective width. This shall be considered for traffic traveling both parallel or perpendicular to the span:

$$E = 4 \text{ ft} + 0.6S \tag{2}$$

where:

E = equivalent distribution width, ft and
 S = design span, ft.

NOTE 4— E width distribution is determined by concrete properties, not soil properties, and may need to be reduced for structural slab widths less than the E width calculated here. Large openings, or unsupported edges of slabs will typically require reduced E widths.

5.1.9 *Distribution of Wheel Loads through Earth Fills:*

5.1.9.1 For below ground structures where earth fill is 2.0 ft or greater above the structure, the vehicle wheel loads shall be distributed as a truncated pyramid as shown in Fig. 3. The loaded area for each wheel shall be:

$$A = (W + 1.15 H) * (L + 1.15 H) \tag{3}$$

where:

A = wheel load area, ft²,
 W = wheel width, ft,
 L = wheel length, ft, and
 H = height of fill between wheels and structure, ft.

5.1.9.2 The design pressure shall be determined in accordance with Fig. 3:

$$WuLL = \frac{P}{A} \tag{4}$$

where:

$WuLL$ = uniform distributed live load (lb/ft²),
 P = as defined in Fig. 1 and Fig. 2, and

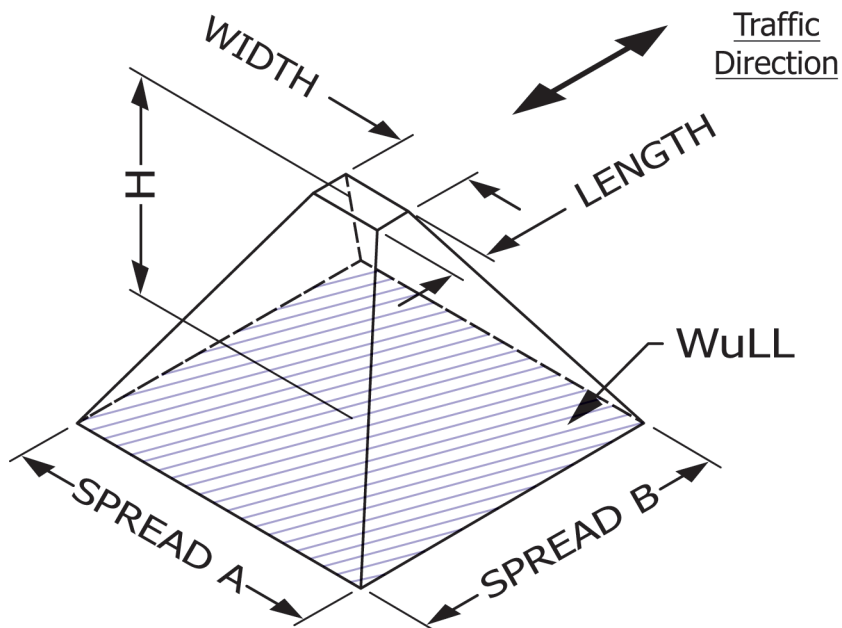

FIG. 3 Vehicle Wheel Loads (Truncated Pyramid)