



Designation: D291/D291M – 20

Standard Test Method for Bulk Density of Crushed Bituminous Coal¹

This standard is issued under the fixed designation D291/D291M; the number immediately following the designation indicates the year of original adoption or, in the case of revision, the year of last revision. A number in parentheses indicates the year of last reapproval. A superscript epsilon (ϵ) indicates an editorial change since the last revision or reapproval.

1. Scope

1.1 This test method covers two procedures for determining the bulk density of crushed coal less than 37.5 mm [1.5 in.] in size, such as is charged into coke ovens, as follows:

1.1.1 *Procedure A*—The cone procedure for determining an uncompacted bulk density.

1.1.1.1 *Standard Method*—Procedure employs the use of a 115 mm [4.5 in.] chute opening and a measuring box having dimensions of 305 mm x 305 mm x 305 mm [12.0 in. x 12.0 in. x 12.0 in.].

1.1.1.2 *Alternate Method*—Procedure employs the use of a 203 mm [8.0 in.] chute opening and a measuring box having dimensions of 203 mm x 203 mm x 305 mm [8.0 in. x 8.0 in. x 12.0 in.] for coals with a total moisture greater than 7 %.

1.1.2 *Procedure B*—The dropped-coal procedure for determining a compacted bulk density, comparable to actual bulk densities attained in coke ovens.

1.2 This test method is not applicable to the testing of powdered coal as used in boiler plants, nor to the determination of the bulk density of coal in storage piles.

1.3 *Units*—The values stated in either SI units or inch-pound units are to be regarded separately as standard. The values stated in each system are not necessarily exact equivalents; therefore, to ensure conformance with the standard, each system shall be used independently of the other, and values from the two systems shall not be combined.

1.4 *This standard does not purport to address all of the safety concerns, if any, associated with its use. It is the responsibility of the user of this standard to establish appropriate safety, health, and environmental practices and determine the applicability of regulatory limitations prior to use.*

1.5 *This international standard was developed in accordance with internationally recognized principles on standardization established in the Decision on Principles for the Development of International Standards, Guides and Recommendations issued by the World Trade Organization Technical Barriers to Trade (TBT) Committee.*

¹ This test method is under the jurisdiction of ASTM Committee D05 on Coal and Coke and is the direct responsibility of Subcommittee D05.15 on Metallurgical Properties of Coal and Coke.

Current edition approved Nov. 1, 2020. Published January 2021. Originally approved in 1927. Last previous edition approved in 2012 as D291 – 07(2012). DOI: 10.1520/D0291_D0291M-20.

2. Referenced Documents

2.1 *ASTM Standards*:²

D440 Test Method of Drop Shatter Test for Coal

D2234/D2234M Practice for Collection of a Gross Sample of Coal

D3038 Test Method for Drop Shatter Test for Coke

D3302/D3302M Test Method for Total Moisture in Coal

D4749 Test Method for Performing the Sieve Analysis of Coal and Designating Coal Size

3. Significance and Use

3.1 This test method concerns the compaction of crushed coal to determine either its compacted or uncompacted bulk density, for purposes such as charging coke ovens.

PROCEDURE A—CONE PROCEDURE FOR UNCOMPACTED BULK DENSITY

4. Apparatus

4.1 *Measuring Box*:

4.1.1 *Standard Method*, of rigid construction, having inside dimensions of 305 mm x 305 mm x 305 mm [12.0 in. x 12.0 in. x 12.0 in.], and a volume of $0.02873 \text{ m}^3 \pm 0.00008 \text{ m}^3$ [$1.000 \text{ ft}^3 \pm .003 \text{ ft}^3$]. The exact volume of the box shall be determined by water calibration.

4.1.2 *Alternate Method*, of rigid construction, having the inside dimensions of 203 mm x 203 mm x 305 mm [8.0 in. x 8.0 in. x 12.0 in.], and a volume of $0.01257 \text{ m}^3 \pm .00003 \text{ m}^3$ [$0.4444 \text{ ft}^3 \pm 0.0012 \text{ ft}^3$]. The exact volume of the box shall be determined by water calibration.

4.2 *Cone*:

4.2.1 *Standard Method*, conforming to Fig. 1 for filling the measuring box. This cone shall be 610 mm [24.0 in.] high and 510 mm [20.0 in.] in inside diameter at the top, with a circular opening 115 mm [4.5 in.] in diameter at the bottom. A slide valve consisting of a sliding-plate shutter and its supports shall be welded to the bottom of the cone in such a manner that the valve may be opened and closed with ease by removing or inserting the shutter in its supporting slides. The cone shall be

² For referenced ASTM standards, visit the ASTM website, www.astm.org, or contact ASTM Customer Service at service@astm.org. For *Annual Book of ASTM Standards* volume information, refer to the standard's Document Summary page on the ASTM website.

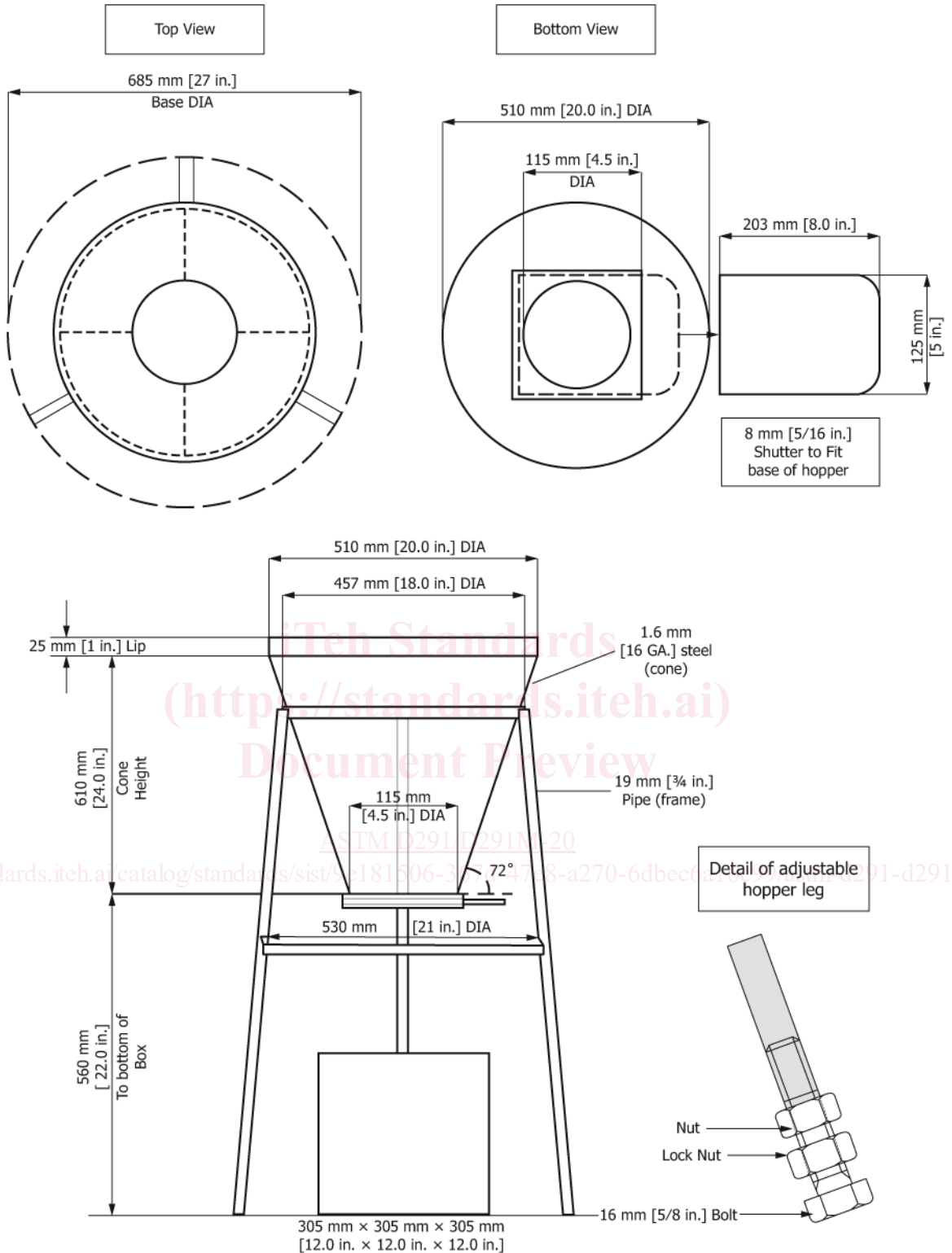

FIG. 1 Example of Apparatus for Cone Procedure: Standard Method

supported in a tripod frame having a circular opening at the top of 457 mm [18.0 in.] in diameter. This frame shall support the cone so that the top-side of the shutter shall be 560 mm [22.0 in.] from the inside bottom surface of the box. An example of the apparatus for the standard cone procedure is shown in Fig. 1.

4.2.2 *Alternate Method*,³ conforming to Fig. 2 for filling the measuring box. This cone shall be 470 mm [18.5 in.] high and

³ Supporting data have been filed at ASTM International Headquarters and may be obtained by requesting Research Report RR:D05-2001. Contact ASTM Customer Service at service@astm.org.

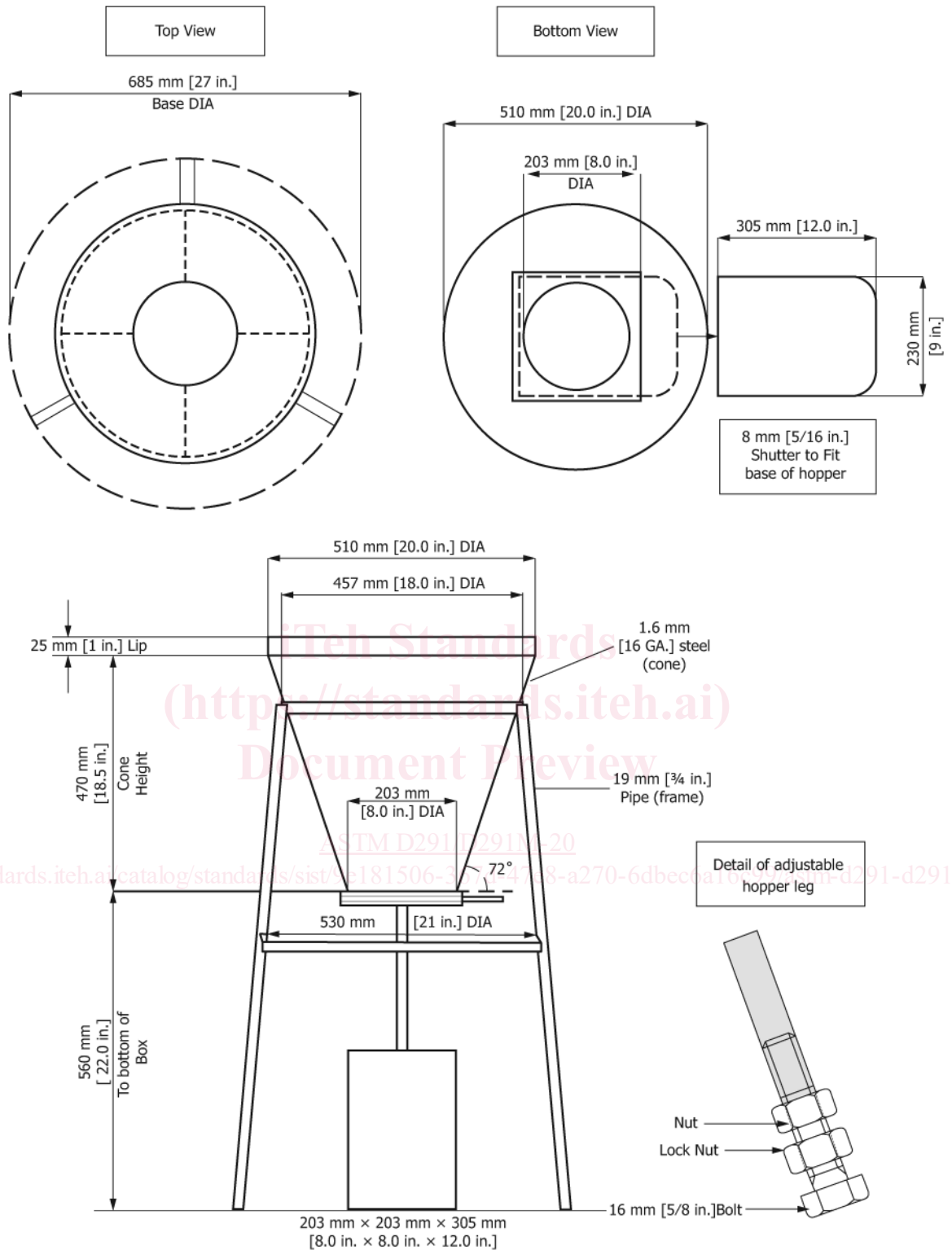

FIG. 2 Example of Apparatus for Cone Procedure: Alternate Method

510 mm [20.0 in.] in inside diameter at the top, with a circular opening of 203 mm [8.0 in.] in diameter at the bottom. A slide valve consisting of a sliding-plate shutter and its supports shall be welded to the bottom of the cone in such a manner that the valve may be opened and closed with ease by removing or inserting the shutter in its supporting slides. The cone shall be

supported in a tripod frame having a circular opening at the top of 457 mm [18.0 in.] in diameter. This frame shall support the cone so that the top-side of the shutter shall be 560 mm [22.0 in.] from the inside bottom surface of the box. An example of the apparatus for the alternate cone procedure is shown in Fig. 2.

4.3 *Leveling Bar*, a steel strip 760 mm [30 in.] long by 37.5 mm [1.5 in.] wide and approximately 5 mm [$\frac{3}{16}$ in.] thick.

4.4 *Scales*, platform, capable of weighing up to 100 kg [220 lb] and sensitive to 0.05 kg [0.1 lb].

5. Sampling

5.1 *Gross Sample*—For collecting gross samples of crushed bituminous coal, the procedures described in Practice **D2234/D2234M** shall apply. During the period of collecting the gross sample, the increments of the sample shall be stored in a waterproof container with a tightly fitting cover in order to prevent the loss of moisture. The minimum number and mass of increments collected shall be in accordance with Table 2 of Practice **D2234/D2234M**. The minimum gross mass of the sample shall be 140 kg [300 lb].

5.2 *Laboratory Sample*—The gross sample of coal shall be thoroughly mixed and subdivided, without crushing, into four 34 kg [75 lb] portions. This operation shall be done as quickly as possible to avoid loss of moisture, and the bulk density shall be determined immediately. If this determination cannot be made immediately, the samples shall be kept in waterproof containers with tightly fitting covers until the time for making the determination.

6. Procedure

6.1 Before filling the cone hopper, level it in its tripod on a solid floor. Pour the prepared sample into a pile on the floor and carefully flatten it to about 100 mm [4 in.] in thickness using a rake or shovel. Avoid pounding of the pile with the back of the shovel. Take successive shovelfuls from uniformly distributed points in the pile and allow them to slide gently from the shovel into the hopper at different peripheral points. This will prevent segregation and packing while the hopper is being filled. Place about 34 kg [75 lb] of coal in the hopper.

6.2 Weigh the empty measuring box to the nearest 0.05 kg [0.1 lb]. Center the previously weighed measuring box under the valve of the cone. Remove the valve shutter completely, allowing all of the coal to flow into the box and overflow the edges. Loosen wet coal, not flowing freely from the hopper, by gently thrusting downward (or poke) through the coal to the valve with the leveling bar.

6.3 After filling the box, carefully level off the excess coal above the box edge by means of the leveling bar, and place the box on the platform scale and weigh it to the nearest 0.05 kg [0.1 lb]. Avoid jarring or shifting of the filled box until all excess coal is leveled off. Record the mass of the filled measuring box to the nearest 0.05 kg [0.1 lb].

6.4 Moisture and size distribution of the coal are the two main factors which affect the bulk density. It is recommended for proper interpretation that a moisture determination and sieve analysis of the coal be reported along with the bulk density result. For directions for determination of the total moisture, see Test Method **D3302/D3302M**. For directions for the determination of size distribution, see Test Method **D4749**. For the purposes of reporting both total moisture and size distribution associated with the bulk density results, the representative sample is taken to be the actual sample employed for

the determination of the bulk density (see Section 5). The minimum gross sample masses required by Test Methods **D3302/D3302M** and **D4749** will not apply.

6.5 For the purpose of simplifying communication between concerned parties in the reporting of the size distribution of the actual bulk density sample, it is recommended to employ the standard series of sieves identified in 6.1.2 of Test Method **D4749** covering from within the actual topsize of the coal down to 6.3 mm ($\frac{1}{4}$ in.). Other sieve sizes may be used.

7. Calculation

7.1 Calculate the uncompacted bulk density, BD_{uncomp} , to the nearest 0.05 kg/m³ [0.1 lb/ft³] as follows:

$$BD_{\text{uncomp, kg/m}^3} [\text{lb/ft}^3] = (W_2 - W_1)/V_1 \quad (1)$$

where:

- W_1 = the mass of the empty measuring box, kg [lb];
- W_2 = the mass of the filled measuring box after leveling as described in 6.3, kg [lb]; and
- V_1 = the measured volume of the measuring box as determined by water calibration as described in 4.1, m³ [ft³].

8. Report

8.1 Report the uncompacted bulk density, BD_{uncomp} , as calculated in Section 7 to the nearest 0.05 kg/m³ [0.1 lb/ft³].

8.2 Report the method, either the Standard Method or Alternate Method, used to determine the BD_{uncomp} .

9. Precision and Bias

9.1 Repeatability:

9.1.1 Duplicate results by the same operator in a given laboratory on consecutive tests determined within a minimum interval of time shall be considered suspect if they differ by more than 9.6 kg/m³ [0.6 lb/ft³].

9.1.2 When two results are obtained that differ by more than this value, two additional tests shall be made. If the second pair of results differs by less than the repeatability, the first pair shall be discarded and the mean of the second pair shall be reported as the result of the test.

9.1.3 When both pairs of results exceed the repeatability, the mean of the four results shall be reported, provided that the two most divergent results differ by less than 13 kg/m³ [0.8 lb/ft³]. Otherwise, all results shall be discarded and the apparatus, procedure, and sample shall be examined for noncompliance causes, which should be corrected before redetermining new pairs of values.

9.2 *Reproducibility*—It is not possible to specify the precision (reproducibility) of the procedure in Test Method **D291/D291M** for measuring the uncompacted bulk density because of the impracticality of obtaining, transporting, and handling representative splits of the materials in the quantities that would be needed to establish the precision statement.

9.3 *Bias*—No information can be presented on the bias of the procedure in Test Method **D291/D291M** for measuring the uncompacted bulk density because the method is empirical and no material having an accepted reference value is available.