



Designation: ~~C110 – 16~~^{ε1} C110 – 20

Standard Test Methods for Physical Testing of Quicklime, Hydrated Lime, and Limestone¹

This standard is issued under the fixed designation C110; the number immediately following the designation indicates the year of original adoption or, in the case of revision, the year of last revision. A number in parentheses indicates the year of last reappraisal. A superscript epsilon (ε) indicates an editorial change since the last revision or reappraisal.

This standard has been approved for use by agencies of the U.S. Department of Defense.

~~ε¹ NOTE—Added research report footnote to Section 24 editorially in January 2017.~~

1. Scope

1.1 These test methods cover physical testing of quicklime and hydrated lime, and of limestone not otherwise covered in ASTM standards.²

NOTE 1—Quicklime and hydrated lime have a high affinity for moisture and carbon dioxide. Caution should be taken to protect both hydrated and quicklime during sampling, storage, and testing (see Practice C50).

1.2 The test ~~procedures~~methods appear in the following order:

	Section
Plastic Property Testing	
Standard Consistency of Lime Putty	5
Plasticity of Lime Putty	6
Water Retention of Hydrated Lime	7
Air Entrainment	8
Soundness Testing	
Autoclave Expansion of Hydrated and Hydraulic Lime	9
Popping and Pitting of Hydrated Lime	10
Application Testing	
Slaking Rate of Quicklime	11
Dry Brightness of Pulverized Limestone	12
Limestone Grindability Determination by the Laboratory Ball Mill —Method	13
Settling Rate of Hydrated Lime	14
Particle Size Analysis	
Residue and Sieve Analysis	15
Sieve Analysis of Dry Limestone, Quicklime, and Hydrated Lime	16
Fineness of Pulverized Quicklime and Hydrated Lime by Air —Permeability	17
Particle Size of Pulverized Limestone	18
Dry Screening of Hydrated Lime, Pulverized Quicklime, and —Limestone by Air Jet Sieving	19
Wet Sieve Analysis of Agricultural Liming Materials	20
Density Measurement	

¹ These test methods are under the jurisdiction of ASTM Committee C07 on Lime and Limestone and are the direct responsibility of Subcommittee C07.06 on Physical Tests.

Current edition approved Dec. 1, 2016/Dec. 1, 2020. Published January 2017/January 2021. Originally approved in 1934. Last previous edition approved in 2016 as C110 – 16/C110 – 16^{ε1}. DOI: 10.1520/C0110-16E01-10.1520/C0110-20.

² For tests on limestone as aggregate, see Vol 04.02 of the *Annual Book of ASTM Standards*. For tests on limestone as building stone, see Vol 04.05 of the *Annual Book of ASTM Standards*.

Apparent Loose Density of Hydrated Lime, Pulverized Quicklime, —and Limestone	21
Apparent Packed Density of Hydrated Lime, Pulverized —Quicklime, and Limestone	22
Relative Density (Specific Gravity) of Hydrated Lime Products	23

Plastic Property Testing

Standard Consistency of Lime Putty	5
Plasticity of Lime Putty	6
Water Retention of Hydrated Lime	7
Air Entrainment	8

Soundness Testing

Autoclave Expansion of Hydrated and Hydraulic Lime	9
Popping and Pitting of Hydrated Lime	10

Application Testing

Slaking Rate of Quicklime	11
Dry Brightness of Pulverized Limestone	12
Limestone Grindability Determination by the Laboratory Ball Mill Method	13
Settling Rate of Hydrated Lime	14

Particle Size Analysis

Residue and Sieve Analysis	15
Sieve Analysis of Dry Limestone, Quicklime, and Hydrated Lime	16
Fineness of Pulverized Quicklime and Hydrated Lime by Air Permeability	17
Particle Size of Pulverized Limestone	18
Dry Screening of Hydrated Lime, Pulverized Quicklime, and Limestone by Air Jet Sieving	19
Wet Sieve Analysis of Agricultural Liming Materials	20

Density Measurement

Apparent Loose Density of Hydrated Lime, Pulverized Quicklime, and Limestone	21
Apparent Packed Density of Hydrated Lime, Pulverized Quicklime, and Limestone	22
Relative Density (Specific Gravity) of Hydrated Lime Products	23

ITeH Standards
 (https://standards.iteh.ai)
 Document Preview

ASTM C110-20

<https://standards.iteh.ai/catalog/standards/sist/98bd2f1-03df-48f9-9cf9-86bb5fe44f10/astm-c110-20>

1.3 The values stated in SI units are to be regarded as standard. The values given in brackets are mathematical conversions to inch-pound units that are provided for information only and are not considered standard.

1.4 *This standard does not purport to address all of the safety concerns, if any, associated with its use. It is the responsibility of the user of this standard to establish appropriate safety, health, and environmental practices and determine the applicability of regulatory limitations prior to use.*

1.5 *This international standard was developed in accordance with internationally recognized principles on standardization established in the Decision on Principles for the Development of International Standards, Guides and Recommendations issued by the World Trade Organization Technical Barriers to Trade (TBT) Committee.*

2. Referenced Documents

2.1 ASTM Standards:³

- C28/C28M Specification for Gypsum Plasters
- C50 Practice for Sampling, Sample Preparation, Packaging, and Marking of Lime and Limestone Products
- C51 Terminology Relating to Lime and Limestone (as Used by the Industry)
- C91 Specification for Masonry Cement
- C109/C109M Test Method for Compressive Strength of Hydraulic Cement Mortars (Using 2-in. or [50 mm] Cube Specimens)
- C136 Test Method for Sieve Analysis of Fine and Coarse Aggregates
- C150 Specification for Portland Cement
- C185 Test Method for Air Content of Hydraulic Cement Mortar

³ For referenced ASTM standards, visit the ASTM website, www.astm.org, or contact ASTM Customer Service at service@astm.org. For *Annual Book of ASTM Standards* volume information, refer to the standard's Document Summary page on the ASTM website.

- C188 Test Method for Density of Hydraulic Cement
- C192/C192M Practice for Making and Curing Concrete Test Specimens in the Laboratory
- C204 Test Methods for Fineness of Hydraulic Cement by Air-Permeability Apparatus
- C207 Specification for Hydrated Lime for Masonry Purposes
- C230/C230M Specification for Flow Table for Use in Tests of Hydraulic Cement
- C231 Test Method for Air Content of Freshly Mixed Concrete by the Pressure Method
- C305 Practice for Mechanical Mixing of Hydraulic Cement Pastes and Mortars of Plastic Consistency
- C430 Test Method for Fineness of Hydraulic Cement by the 45- μ m (No. 325) Sieve
- C472 Test Methods for Physical Testing of Gypsum, Gypsum Plasters, and Gypsum Concrete
- C595 Specification for Blended Hydraulic Cements
- C670 Practice for Preparing Precision and Bias Statements for Test Methods for Construction Materials
- C702 Practice for Reducing Samples of Aggregate to Testing Size
- C778 Specification for Standard Sand
- C1005 Specification for Reference Masses and Devices for Determining Mass and Volume for Use in Physical Testing of Hydraulic Cements
- C1107 Specification for Packaged Dry, Hydraulic-Cement Grout (Nonshrink)
- D75 Practice for Sampling Aggregates
- E11 Specification for Woven Wire Test Sieve Cloth and Test Sieves
- E29 Practice for Using Significant Digits in Test Data to Determine Conformance with Specifications
- E177 Practice for Use of the Terms Precision and Bias in ASTM Test Methods
- E691 Practice for Conducting an Interlaboratory Study to Determine the Precision of a Test Method

3. Terminology

3.1 *Definitions*—Unless

3.1.1 Unless otherwise specified, for definitions of terms used in these test methods see Terminology C51. otherwise specified, for definitions of terms used in these test methods see Terminology C51.

4. General Procedures

4.1 *Sampling*—Samples of lime and limestone for physical analysis shall be taken and prepared in accordance with the requirements of Practice C50 applicable to the material to be tested.

4.2 *Calculation:*

4.2.1 The calculations included in the individual procedures sometimes assume that the exact weight specified has been used. Accurately weighed samples which are approximately but not exactly equal to the weight specified may be used provided appropriate corrections are made in the calculation. Unless otherwise stated, weights of all samples and residues should be recorded to the nearest 0.0001 g.

4.2.2 In all mathematical operations on a set of observed values, the equivalent of two more places of figures than in the single observed values shall be retained. For example, if observed values are read or determined to the nearest 0.1 mg, carry numbers to the nearest 0.001 mg in calculation.

4.3 *Rounding Figures*—Rounding of figures to the nearest significant place required in the report should be done after the calculations are completed, in order to keep the final results free from calculation errors. The rounding procedure should follow the principle outlined in Practice E29.

PLASTIC PROPERTY TESTING

5. Standard Consistency of Lime Putty

5.1 *Significance and Use:*

5.1.1 In order to measure certain physical properties of a lime putty, such as plasticity, it is necessary to have a uniform or standard consistency (viscosity), since the property measurement is affected by the consistency level.

5.2 Apparatus:

5.2.1 *Modified Vicat Apparatus*—The apparatus, constructed as shown in Fig. 1, shall consist of a bracket, A, bearing a movable brass rod, B, 6.3 mm in diameter and of suitable length to fit the Vicat bracket. A plunger, C, 12.5 mm in diameter, made of aluminum tubing, shall be attached to the lower end of the rod. The total weight of the rod with plunger shall be 30 g. The lower end of the plunger shall be closed without shoulders or curvature and the tube may be loaded with shot to the specified weight. The total weight required may also be obtained by means of a weight, D, screwed into the rod. The rod can be held in any position by means of a screw, E, and has a mark midway between the ends which moves under a scale, F, graduated in millimetres, attached to the bracket, A.

5.2.2 *Mold*—The conical ring mold shall be made of a noncorroding, nonabsorbent material, and shall have an inside diameter of 70 mm at the base and 60 mm at the top, and a height of 40 mm.

5.2.3 *Base Plate*—The base plate for supporting the ring mold shall be of plate glass and about 100 mm square.

5.2.4 *Mechanical Mixers*.

5.3 Standard Consistency Determination:

5.3.1 *Mechanical Mixing Procedure Using the Vac-U-Mixer*—To a measured amount of water contained in an ~~800-cm~~800 cm³ Vac-U-Mix bowl, add 300 g of hydrated lime and hand mix for 10 s with a stiff spatula (Note 2). Cover putty to prevent evaporation of water. After the applicable soaking period, 30 min maximum for Type S, special hydrated lime, and not less than 16 h nor more than 24 h for Type N, normal hydrated lime, insert the paddle assembly and mix the putty for 30 s with the mechanical mixer. Remove the paddle assembly and scrape down any putty adhering to it and to the sides of the mixing bowl. Remix for 30 s and determine the consistency as prescribed in 5.3. If the penetration is less than 15 mm, return all of the material to the mixer bowl, add additional water, and remix for 15 s. If the penetration is greater than 25 mm, repeat the test.

NOTE 2—Most lime hydrates will require 250 to 300 mL of water to produce a putty of proper consistency for this test if 300 g of lime are used.

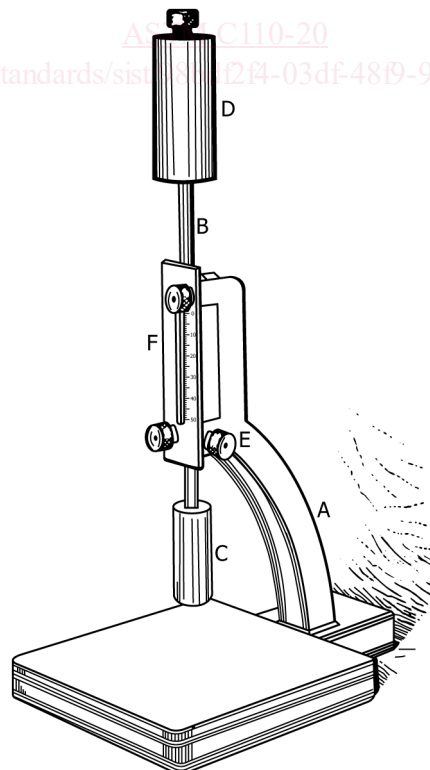

FIG. 1 Modified Vicat Apparatus

5.3.2 *Mechanical Mixing Procedure Using the Hobart N-50 Mixer*—To a measured amount of water contained in the N-50 mixing bowl, add 600 g of hydrated lime and hand mix for 10 s with a stiff spatula (Note 3). Cover putty to prevent evaporation of water. After the applicable soaking period, 30 min maximum for Type S, special hydrated lime, and not less than 16 h nor more than 24 h for Type N, normal hydrated lime, insert the paddle assembly and mix the putty for 1 min at a slow speed. Stop the mixer and scrape down the paddle and the sides of the mixing bowl. Remix for 4 min at a slow speed. Determine the consistency as prescribed in 5.3.3. If the penetration is less than 15 mm, return all of the material to the mixing bowl, add additional water, and remix for 15 s. If the penetration is more than 25 mm, repeat the test.

NOTE 3—Most lime hydrates will require 500 to 600 mL of water to produce a putty of proper consistency for this test if 600 g of lime are used.

5.3.3 *Consistency Determination*—To determine consistency, place the mold with its larger end resting on the glass base plate and fill with the lime putty. Then strike off the putty flush with the top of the mold. Center the lime putty, confined in the ring mold resting on the plate, under the rod of the modified Vicat apparatus (Fig. 1). Bring the plunger end, C, in contact with the surface of the lime putty and take an initial reading. Release the rod and take the final reading 30 s after the plunger is released. The lime putty is of standard consistency when a penetration of 20 ± 5 mm is obtained. Record both the total amount of water required to bring the putty to standard consistency and the actual penetration. Proceed with the plasticity determination in accordance with 6.3.

5.4 *Precision and Bias:*

5.4.1 The precision and bias of this test method has not been determined.

6. **Plasticity of Lime Putty**

6.1 *Significance and Use:*

iTeh Standards
(<https://standards.itih.ai>)
Document Preview

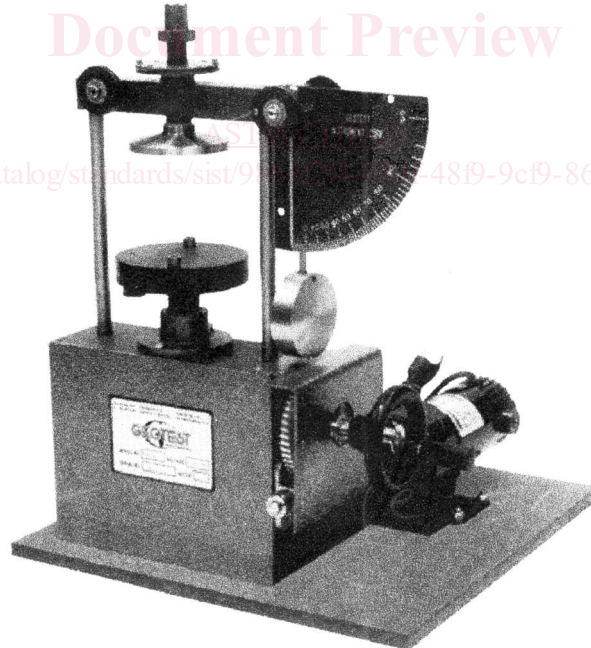

Constants of the Machine:

Absorption of Porcelain and Plaster Base Plate—~~minimum~~—Minimum of 40 g in 24 h. For rate of absorption of base plates see 6.2.3.2.

Dimension of Base Plate—25 mm [1 in.] in thickness by 100 mm [4 in.] in diameter.

Dimensions of Disk—0.8 to 12.7 mm [$\frac{1}{32}$ to $\frac{1}{2}$ in.] in thickness by 76 mm [3 in.] in diameter.

Speed of Vertical Shaft—One revolution in 6 min, 40 s.

Torque on Disk when Bob Reading is 100—1.41 N·m.

FIG. 2 Emley Plasticimeter

6.1.1 This test method provides a measure of the degree of stiffening of lime putty of standard consistency as water is withdrawn from it by a standard suction base plate.

6.1.2 Plasticity is an important property when applying mixtures containing lime putty to porous or absorptive surfaces such as in plastering, stuccoing, and masonry construction.

6.2 Apparatus:

6.2.1 Determine the plasticity of lime putty using the plasticimeter shown in Fig. 2.⁴

6.2.2 *Cleaning and Care of Base Plates*—Base plates may be made of porcelain or plaster. In making the plasticity determinations, much of the success attainable depends upon the condition of the base plates. In the case of porcelain plates which are reused, improper cleaning results in clogging of the pores with reduction in the rate of absorption. After a porcelain plate has been used, wipe the excess lime off and immerse the plate in clear water for not less than 2 h, after which transfer it without drying to a dilute solution of hydrochloric acid (HCl, 1 + 9) where it shall be kept immersed for another 2 h. Then transfer to a receptacle containing running water for at least 1 h. The plate is then free of acid. After the removal of excess water, place the plate in an oven overnight at a temperature of between 100 and 110 °C for drying. Before using, cool the plate to room temperature. In the case of plaster base plates, dry the base plates prior to use in plasticity or absorption testing in an oven at a temperature between 37.8 and 48.9 °C until they achieve a constant weight. Before using, cool the plaster plate to room temperature in a dessicator charged with a drying agent. If the plate is not to be used immediately after reaching room temperature, continue to store the plate in the dessicator until such time that it is to be used. Plaster base plates shall not be reused after plasticity, total absorption, or rate of absorption testing (see 6.2.3).

6.2.3 Absorption of Plasticimeter Base Plates:

6.2.3.1 *Total Absorption*—Plasticimeter base plates when immersed in water at room temperature for a period of 24 h shall absorb not less than 40 g of water. Before making the determination, dry the porcelain plates overnight in an oven at a temperature between 100 and 110 °C and permit to cool to room temperature. Dry the plaster plates in an oven at a temperature between 37.8 and 48.9 °C until they achieve a constant weight and permit to cool to room temperature in a dessicator charged with a drying agent. After immersion and before weighing either porcelain or plaster plates, wipe off the excess water with a damp cloth.

6.2.3.2 *Rate of Absorption (Note 4)*—When tested over an area 70 mm [2¾ in.] in diameter, the water absorbed by either porcelain or plaster base plates shall be in accordance with the following:

Time, min	Water Absorbed, mL
1	8 to 14
2	5 to 7½
3	4 to 6½
4	4 to 6
5	3½ to 5½

(1) Plaster plates designated for rate of absorption testing shall be statistically representative of all plates manufactured for that purpose and made from one manufacturing batch run. Plaster plates selected for rate of absorption testing may not be re-dried and used for plasticity testing. Porcelain plates designated for rate of absorption testing shall be individually tested and may be re-dried and used for plasticity testing (see 6.2.2).

NOTE 4—A convenient apparatus for determining the rate of absorption consists of a buret sealed onto an inverted glass funnel from which the stem has been removed. The diameter of the larger end of the funnel shall be ground so as to be 70 mm [2¾ in.] in internal diameter. The funnel may be attached to the plate on which the measurement is being made by melted paraffin. The paraffin should not be too hot. A little experience will indicate when it is of the proper consistency. Alternative apparatus manufactured of polycarbonate, metal, and other materials are acceptable.⁵

6.3 Plasticity Determination:

⁴ The sole source of supply of the Emley Plasticimeter apparatus known to the committee at this time is Geotest Instrument Corporation, 910 University Place, Evanston, IL 60201, USA. If you are aware of alternative suppliers, please provide this information to ASTM International Headquarters. Your comments will receive careful consideration at a meeting of the responsible technical committee, which you may attend.

⁵ Godbey, Richard R. J. and Thomson, Margaret L., "Standardized M. L.," "Development of a Standardized Laboratory Apparatus for Measuring Emley Baseplate Rate of Absorption," *Rochell Jaffe, Ed., Proceedings: 2005-International-Proceedings of the International Building Lime Symposium*, Michael Tate, Chairperson, National Lime Association, Arlington, VA, ISBN 0-9767621-0-2, Orlando, FL, 2005.

6.3.1 Lubricate a ring mold such as is described in 5.2.2 with a thin film of water, place on a porcelain base plate (see 6.2.2 and 6.2.3) or a disposable plaster base plate (see 6.2.3), fill with the paste which has been adjusted to standard consistency as described in 5.3.3, and strike off level. Remove the mold by raising it vertically without distorting the paste. Center the base plate and paste in the instrument and turn the carriage up by hand until the surface of the paste is in contact with the disk and the distance between the disk and the top of the base plate is 32 mm [1¼ in.]. Throw the carriage into gear and start the motor. It is essential that the motor be started exactly 120 s after the first portion of the paste has been placed in the mold. Record the time when the first portion of paste is placed in the mold as zero time; the motor is therefore started at 2 min. Take care to protect the specimen from drafts during the test.

6.3.2 Record the scale reading at 1 min intervals until the test is completed. Consider the test complete when: (1) the scale reading reaches 100, (2) any reading is less than the one before, or (3) the scale reading remains constant for three consecutive readings (2 min) and the specimen has visibly ruptured or broken loose from the base plate. Note the time and the scale reading at the end of the test.

6.4 Calculation:

6.4.1 Calculate the plasticity figure as follows:

$$P = \sqrt{F^2 + (10T)^2} \quad (1)$$

where

P = plasticity figure,

F = scale reading at the end of the test, and

T = time in minutes from the time when the first portion of paste was put in the mold to the end of the test.

6.5 Precision and Bias:

6.5.1 The precision of this test method is based on interlaboratory studies conducted in March and October of 2007. To determine interlaboratory and intralaboratory precision, one operator from each of ten different laboratories tested three different dolomitic Type S hydrated lime samples and one dolomitic Type N hydrated lime sample made into lime putty of standard consistency for Final Vicat Penetration (mm) and Calculated Plasticity Figure (Emley Units). Each laboratory obtained three replicate test results for each of the supplied materials.⁶ Statistical summaries of the testing results are shown in Tables 1 and 2.

6.5.1.1 *Repeatability*—Two test results obtained within one laboratory shall be judged not equivalent if they differ by more than the “ r ” value for that material; “ r ” is the interval representing the critical difference between two test results for the same material, obtained by the same operator using the same equipment on the same day in the same laboratory.

6.5.1.2 *Reproducibility*—Two test results should be judged not equivalent if they differ by more than the “ R ” value for that

TABLE 1 Final Vicat Penetration (mm)

MATERIAL	Average	Repeatability Standard Deviation	Reproducibility Standard Deviation	Repeatability Limit	Reproducibility Limit	
	Material	Average	Repeatability Standard Deviation	Repeatability Standard Deviation	Repeatability Limit	Reproducibility Limit
	\bar{x}	\bar{s}_r	s_r	s_R	r	R
	\bar{x}	s_r	s_R	r	R	
Type S Hydrated Lime Samples A, C, F	19.7	2.76	2.81	7.7	7.9	
Type S Hydrated Lime Samples B, E, G	18.4	2.13	2.53	5.9	7.1	
Type S Hydrated Lime Samples D H I	18.4	2.83	2.83	7.9	7.9	
Type N Hydrated Lime	17.8	2.59	2.59	7.3	7.3	

⁶ Supporting data have been filed at ASTM International Headquarters and may be obtained by requesting Research Report RR:C07-1005. Contact ASTM Customer Service at service@astm.org.

TABLE 2 Calculated Plasticity Figure (Emley Units)

MATERIAL	Average	Repeatability Standard Deviation	Reproducibility Standard Deviation	Repeatability Limit	Reproducibility Limit
	Material	Average	Repeatability Standard Deviation	Repeatability Standard Deviation	Repeatability Limit
	\bar{x}	s_r	s_R	r	R
Type S Hydrated Lime Samples A, C, F	502	22.70	41.62	64	117
Type S Hydrated Lime Samples B, E, G	480	42.93	66.77	120	187
Type S Hydrated Lime Samples D H I	381	40.52	49.11	114	138
Type N Hydrated Lime	438	25.06	53.51	70	150

material; “R” is the interval representing the difference between two test results for the same material, obtained by different operators using different equipment in different laboratories.

6.5.1.3 Any judgment in accordance with statements 6.5.1.1 or 6.5.1.2 would have an approximate 95 % probability of being correct. To judge the equivalency of two test results, it is recommended to choose the material closest in characteristics to the test material (Type S or Type N hydrated lime).

6.5.2 *Bias*—At the time of the studies, there was no accepted reference material suitable for determining the bias for this test method, therefore no statement on bias can be made. To judge the equivalency of two test results, it is recommended to choose the material closest in characteristics to the test material (Type S or Type N hydrated lime).

7. Water Retention of Hydrated Lime

7.1 Significance and Use:

7.1.1 This test method measures the ability of the hydrated lime in a plastic mix with sand to retain water, and hence retain consistency of the mix, when subjected to an applied suction. This ability, measured as a percent of the original consistency, is indicative of the workability to be expected in a masonry mortar containing the lime.

7.2 Proportioning and Mixing:

7.2.1 *Apparatus*—The apparatus used shall conform to Practice C305.

7.2.2 *Proportions*—The mortar tested shall be composed of 500 g of lime and 1500 g of standard sand conforming to 8.2.3. If hydrated lime putty is used, use that weight of putty that is equivalent to 500 g of dry hydrated lime.

7.2.3 Mechanical Mixing:

7.2.3.1 Place the dry paddle and the dry bowl in the mixing position in the mixer.

7.2.3.2 Place a measured quantity of water in the bowl.

7.2.3.3 Add the lime to the water, then start the mixer and mix at slow speed (140 ± 5 r/min) for 30 s.

7.2.4 Add the entire quantity of sand slowly over a 30 s period while mixing at slow speed.

7.2.5 Stop the mixer, change to medium speed (285 ± 10 r/min) and mix for 30 s.

7.2.6 Stop the mixer and let the mortar stand for 1½ min. (During the first 15 s of this interval, quickly scrape down into the batch any mortar that may have collected on the side of the bowl, then for the remainder of this interval cover the bowl with the lid.)

7.2.7 Finish the mixing for 1 min at medium speed.

7.2.8 In any case requiring a remixing interval, any mortar adhering to the side of the bowl shall be quickly scraped down into the batch prior to remixing.

7.3 Consistency:

7.3.1 *Apparatus*—The flow table and mold used for the measurement of consistency of the mortar shall conform to Specification **C230/C230M**.

7.3.2 *Procedure*—Carefully wipe dry the flow table top and place the flow mold at the center. Immediately after completing the mixing operation, fill the mold with mortar gently pressed into place by the finger tips to ensure uniform filling free of voids. Smooth off the mortar level with the top of the mold by aid of a trowel, and remove the mold. Immediately drop the table through a height of 13 mm [$\frac{1}{2}$ in.], 25 times in 15 s. The flow is the resulting increase in diameter of the mortar mass, expressed as the percentage of the original diameter. The mortar may be adjusted, if the flow is below 100 %, by additions of water until the flow is within the range from 100 to 115 %. Make each adjustment by returning the mortar to the original mixing bowl, add water, and then mix at medium speed (285 ± 10 r/min) for 30 s. If the flow of the original mortar is greater than 115 %, prepare a new batch.

7.4 Water Retention Test:

7.4.1 *Apparatus*—The equipment shall conform to the apparatus used for the water retention test in Specification **C91** (see **Fig. 3**).

7.4.2 Procedure:

7.4.2.1 Adjust the vacuum regulator to maintain a vacuum of 51 ± 3 mm as measured on the vacuum gauge. Seat the perforated dish on the greased gasket of the funnel. Place a wetted filter paper in the bottom of the dish. Turn the stopcock to apply the vacuum to the funnel and check the apparatus for leaks and to determine that the required vacuum is obtained. Then turn the stopcock to shut off the vacuum from the funnel.

7.4.2.2 Immediately after the final consistency test (7.3.2), return all of the mortar to the bowl and remix the entire batch for 15 s at medium speed. Immediately after remixing the mortar, fill the perforated dish with the mortar to slightly above the rim. Tamp the mortar 15 times with the tamper. Apply ten of the tamping strokes at approximately uniform spacing adjacent to the rim of the dish and with the long axis of the tamping face held at right angles, to the radius of the dish. Apply the remaining five tamping strokes at random points distributed over the central area of the dish. The tamping pressure shall be just sufficient to ensure filling of the dish. On completion of the tamping, the top of the mortar should extend slightly above the rim of the dish. Smooth off the mortar by drawing the flat side of the straightedge (with the leading edge slightly raised) across the top of the dish. Then cut off the mortar to a plane surface flush with the rim of the dish by drawing the straightedge with a sawing motion across the top of the dish in two cutting strokes, starting each cut near the center of the dish. If the mortar is pulled away from the side of the dish during the process of cutting off the excess mortar, gently press the mortar back into contact with the side of the dish using the tamper.

7.4.2.3 Turn the stopcock to apply vacuum to the funnel. After suction for 60 s, quickly turn the stopcock to expose the funnel to atmospheric pressure. Immediately slide the perforated dish off the funnel, touch it momentarily on a damp cloth to remove droplets of water, and set the dish on the table. Then, using the bowl scraper (rubber scraper as specified in Practice **C305**), plow and mix the mortar in the dish for 15 s. Upon completion of mixing, place the mortar in the flow mold and determine the flow. Carry out the entire operation without interruption and as quickly as possible. Not more than 30 min should be required for completion, starting from the completion of the mixing of the mortar for the first flow determination.

7.4.3 Calculation:

7.4.3.1 Calculate the water retention value for the mortar as follows:

$$\text{Water retention value} = (A/B) \times 100 \quad (2)$$

where:

A = flow after suction, and

B = flow immediately after mixing.

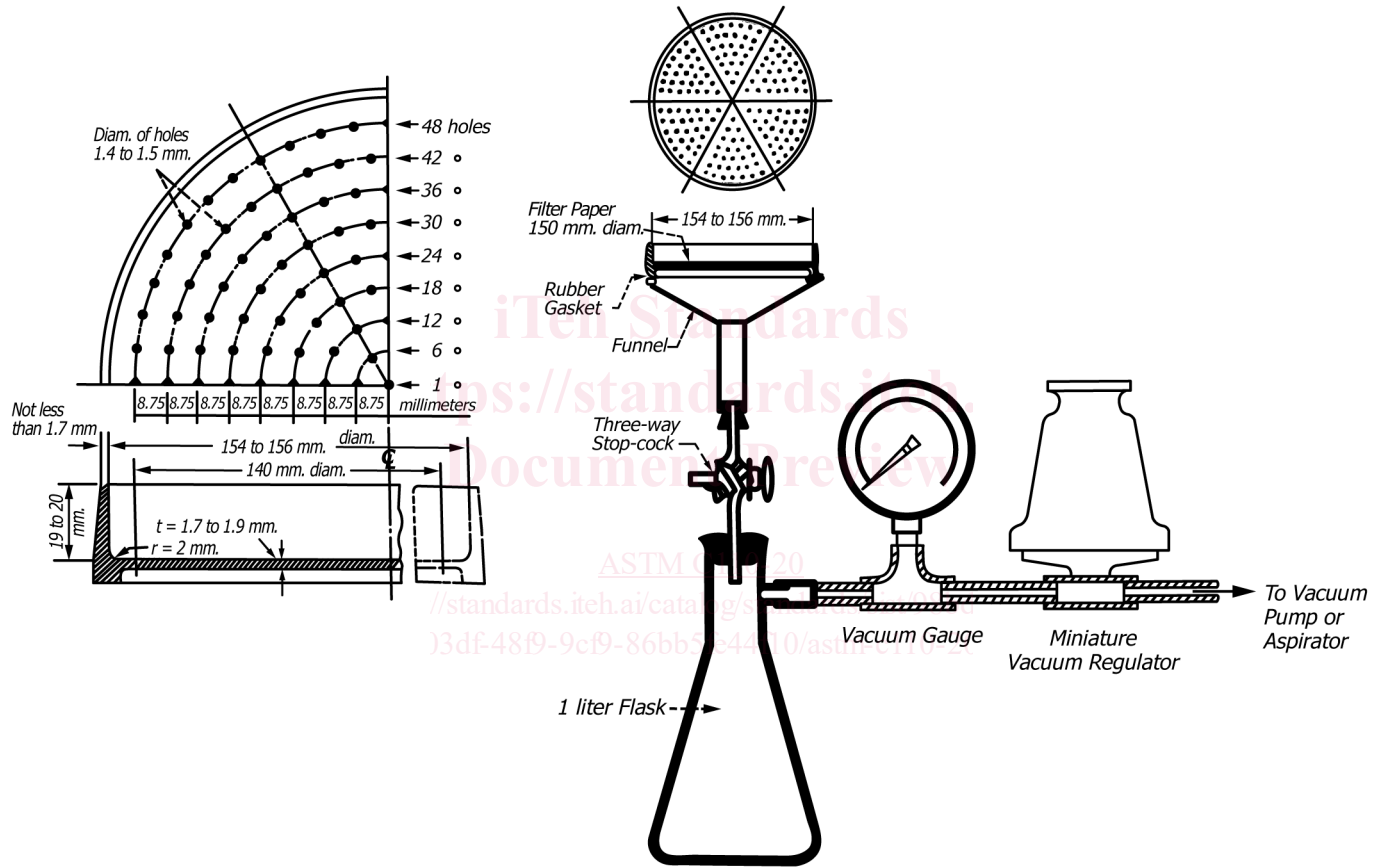

FIG. 3 Vacuum Gauge Apparatus Assembly for Water Retention Test

7.5 Precision and Bias:

7.5.1 No precision data are available due to the limited use of this test method. Therefore, users are advised to develop their own laboratory precision.

8. Air Entrainment

8.1 Significance and Use:

8.1.1 Hydrated lime, particularly that containing an air-entraining additive, used in masonry mortar may contribute to the air content of the mortar. Certain specifications and applications of mortar place a limit on this air content.

8.2 Apparatus:

8.2.1 *Flow Table*, conforming to the requirements prescribed in Specification **C230/C230M**.

8.2.2 *Mixing Apparatus*, conforming to the requirements as prescribed in Practice **C305**.

8.2.3 The sand shall be a blend of equal parts by weight of graded Ottawa sand and standard 20-30 Ottawa sand. The fineness of graded Ottawa sand and standard 20-30 sand may be checked by using the test methods described in Specification **C778**.

8.3 Preparation of Mortar:

8.3.1 *Proportions for Mortar*—Lime-based mortars for measurement of air entrainment shall be proportioned to conform, in batch size, to the unit weights by volume of cementitious material and aggregate as shown in **Table 3**. The cement shall conform to Specifications **C150**, **C595**, or **C1107**, and the hydrated lime to Specification **C207**. The quantity of water, measured in millilitres, shall be such as to produce a flow of $110 \pm 5\%$ as determined by the flow table. Proportions for the generally used batch sizes based on **Table 3** material unit weight shall contain the weights as prescribed in **Table 4**.

8.3.2 *Mixing of Mortars*—Mix the mortar in accordance with the procedure for mixing pastes in Practice **C305**.

8.3.3 *Determination of Flow*—Determine the flow in accordance with the Procedure section of Test Method **C109/C109M**.

<https://standards.iteh.ai/catalog/standards/sist/98bd22f4-03df-48f9-9c19-86bb5fe44f10/astm-c110-20>

8.4 Procedure:

8.4.1 If the mortar has the correct flow, use a separate portion of the mortar for the determination of entrained air. The amount of air entrainment shall be determined by one of two methods. The density method determines air content from the measured density of the mortar, the known density of constituents, and the mixture properties. The air pail method measures air content using Test Method **C231**.

8.4.2 Density Method:

TABLE 3 Unit Weights and Apparent Specific Gravities

Materials	Unit weight, kg/m ³ [lb/ft ³] ^A	Specific Gravity
Materials	Unit Weight, kg/m ³ [lb/ft ³] ^A	Specific Gravity
Portland Cement	1,504 [94]	3.15
Blended Cement	obtain from purchaser	B
Blended Cement	B	—
Hydraulic Cement	obtain from purchaser	B
Hydraulic Cement	B	B
Hydrated Lime	640 [40]	2.30
Blended Ottawa Silica Sand	1,280 [80]	2.65

^A The unit weight values listed for cementitious materials are assumed values commonly used in construction practice.

^B Obtain from purchaser.

TABLE 4 Weight of Materials for Mortar Batch

Mortar Type	Proportions by Volume	Portland Cement (g)	Hydrated Lime (g)	Blended Ottawa Silica Sand (g)	Portland Cement (g)	Hydrated Lime (g)	Blended Ottawa Silica Sand (g)
M	1:1/4:3 3/4	470.0	62.5	1,500	470.0	62.5	1,500
M	1:1/4:3 3/4	470.0	62.5	1,500	470.0	62.5	1,500
S	1:1/2:4 1/2	376.0	100.0	1,440	376.0	100.0	1,440
N	1:1:6	282.0	150.0	1,440	282.0	150.0	1,440
O	1:2:9	188.0	200.0	1,440	188.0	200.0	1,440
Lime/Sand	1:3		300.0	1,440		300.0	1,440

8.4.2.1 *Apparatus*—*Apparatus*—Scales, Sieves, Glass Graduates, Tamper, Measure, Straightedge, Spatula, Tapping Stick, and Spoon, conforming to the requirements given in Test Method C185.

8.4.2.2 *Procedure*:

- (1) Fill a 400 ml measure with the mortar sample in accordance with Test Method C185.
- (2) Determine the weight of mortar in the measure.

8.4.2.3 *Calculation*—Calculate the air content of the mortar and report it to the nearest 0.1 % as follows:

$$D = (W_1 + W_2 + W_3 + V_w) / \quad (3)$$

$$[(W_1/S_1) + (W_2/S_2) + (W_3/S_3) + V_w] A = 100 - (W_m/4D)$$

where:

- D = density of air-free mortar,
- W_1 = weight of cement, g,
- W_2 = weight of lime, g,
- W_3 = weight of blended Ottawa sand, g,
- V_w = water used, mL,
- S_1 = specific gravity of portland cement,
- S_2 = specific gravity of hydrated lime,
- S_3 = specific gravity of blended Ottawa sand,
- A = volume % of entrained air, and
- W_m = weight of 400 mL of mortar, g.

NOTE 5—For lime/sand mortars, W_1 and S_1 should be dropped from the calculation.

8.4.2.4 *Precision and Bias*:

(1) The single operator within laboratory standard deviation has been found to be 0.56 % air content throughout the range of 8 to 19 % air content. Therefore results of two properly conducted tests by the same operator on similar batches of mortar should not differ by more than 1.6 % air content.

(2) The multilaboratory standard deviation has been found to be 1.0 % air content throughout the range of 8 to 19 % air content. Therefore, results of two different laboratories on similar batches of mortar should not differ from each other by more than 2.8 % air content (see Test Method C185).

8.4.3 *Air Pail Method*:

8.4.3.1 *Apparatus*:

(1) *Air Meters*—There are two basic operational designs employing the principle of Boyle’s law. Both types of units are detailed in Test Method C231.

(2) *Calibration Vessel, Spray Tube, Tamping Rod, Mallet, Strike-Off Bar, Funnel, and Water Measure*, conforming to the requirements given in Test Method C231.

8.4.3.2 *Procedure*:

- (1) Calibrate the air meter using procedures described in Test Method C231, Section 5.

(2) Fill the air meter and determine air content by using the method detailed in Test Method **C231** Section 8, except that for Type B meters with a volume of 1 L or less, there shall be no use of an internal vibrator as required in Test Method **C231** and described in Practice **C192/C192M**.

(3) When using Type B meters with a volume of 1 L or less, compact the mortar into the bowl by tamping the mortar 15 times with a tamper meeting the requirements of Test Method **C185**, Section 5. Apply ten of the tamping strokes near the outside circumference of the mortar bowl evenly spaced at right angles to the radius of the bowl and five of the tamping strokes at random points distributed in the center of the bowl. Apply the tamping strokes in such a manner as to only settle and consolidate the mortar into the bowl without the addition of voids left by the insertion and removal of the tamper at each stroke.

8.4.3.3 *Precision and Bias*—Although precision for the test method for air content of freshly mixed concrete has been reported in Test Method **C231**, the precision of this test method has not been determined for lime-based mortars. When sufficient data has been obtained and analyzed, a statement of precision will be provided. In the meantime users of the test method are advised to develop their own.

SOUNDNESS TESTING

9. Autoclave Expansion of Hydrated and Hydraulic Lime

9.1 *Significance and Use:*

9.1.1 Expansion of pressed tablets of hydrated and hydrated or pozzolanic hydraulic lime generally indicates the presence of unhydrated oxides of magnesium and calcium or other expansive material. The relation of the degree of expansion in this test method to field performance has not been determined.

9.2 *Apparatus:*

9.2.1 *Mold and Press*—A steel mold capable of producing a press tablet at least 0.032 m [1.25 in.] in diameter and 0.006 m [0.25 in.] thick, and able to sustain at least 88.9 kN [20 000 lbf] pressure from a suitable press. It should be provided with a release jig also.

9.2.2 *Autoclave*, capable of holding 1034 kPa [150 psi] for 2 h.

9.2.3 *Micrometer*, dial-type, capable of measuring 2.54 μm [0.0001 in.].

9.2.4 *Microscope*, with graduated lens for measuring 0.10 mm.

9.3 *Procedure for Expansion Testing:*

9.3.1 *Hydrated Lime*—Weigh out 15 g of hydrated sample, place in the mold, and press into a tablet. Press to 33.4 kN [7500 lbf] for 10 s, then increase pressure to 88.9 kN [20 000 lbf] or more. Hold for 10 s before releasing. Press tablet from mold with jig and draw three diameter lines across the surface of the tablet using a lead pencil. Draw two diameter lines normal to each other and draw the third bisecting the 90° angles of the other two. Measure the diameters with a dial micrometer and place the tablet on the autoclave rack. Use aluminum foil to protect the tablets from water dripping. Autoclave at 862 to 1034 kPa [125 to 150 psi] for 2 h. Begin timing when the pressure reaches 345 kPa [50 psi]. After the autoclaving interval, allow the autoclave to cool, remove the tablet, and remeasure the diameters. Calculate the average percent expansion of the tablet from the before and after measurements.

9.3.2 *Hydrated and Pozzolanic Hydraulic Lime*—Follow the test method of 9.3.1 with the exception use 25 g of material. Place in the mold with 5 g of potable water and mix well. If it is not possible to mix with water in the mold, do so in a suitable container, ensuring that all of the material is transferred to the mold. Press to 6.89 kN and hold for 10 s before releasing.

9.4 *Expansion of Hydrated Lime-Portland Cement-Aggregate:*

9.4.1 *Materials:*

9.4.1.1 *Standard Cement*—Type I or Type II portland cement.