



Designation: D7683 – 21

Standard Test Method for Cloud Point of Petroleum Products and Liquid Fuels (Small Test Jar Method)¹

This standard is issued under the fixed designation D7683; the number immediately following the designation indicates the year of original adoption or, in the case of revision, the year of last revision. A number in parentheses indicates the year of last reapproval. A superscript epsilon (ϵ) indicates an editorial change since the last revision or reapproval.

1. Scope*

1.1 This test method covers the determination of the cloud point of petroleum products, biodiesel, and biodiesel blends that are transparent in layers 40 mm in thickness, using an automatic instrument.

1.2 The measuring range of the apparatus is from $-65\text{ }^{\circ}\text{C}$ to $+51\text{ }^{\circ}\text{C}$, however the precision statements were derived only from samples with cloud point temperatures from $-50\text{ }^{\circ}\text{C}$ to $+6\text{ }^{\circ}\text{C}$.

1.3 The values stated in SI units are to be regarded as standard. No other units of measurement are included in this standard.

1.4 *This standard does not purport to address all of the safety concerns, if any, associated with its use. It is the responsibility of the user of this standard to establish appropriate safety, health, and environmental practices and determine the applicability of regulatory limitations prior to use.*

1.5 *This international standard was developed in accordance with internationally recognized principles on standardization established in the Decision on Principles for the Development of International Standards, Guides and Recommendations issued by the World Trade Organization Technical Barriers to Trade (TBT) Committee.*

2. Referenced Documents

2.1 ASTM Standards:²

[D2500 Test Method for Cloud Point of Petroleum Products and Liquid Fuels](#)

[D4057 Practice for Manual Sampling of Petroleum and Petroleum Products](#)

[D4177 Practice for Automatic Sampling of Petroleum and Petroleum Products](#)

¹ This test method is under the jurisdiction of ASTM Committee D02 on Petroleum Products, Liquid Fuels, and Lubricants and is the direct responsibility of Subcommittee D02.07 on Flow Properties.

Current edition approved Jan. 1, 2021. Published January 2021. Originally approved in 2011. Last previous edition approved in 2020 as D7683 – 20. DOI: 10.1520/D7683-21.

² For referenced ASTM standards, visit the ASTM website, www.astm.org, or contact ASTM Customer Service at service@astm.org. For *Annual Book of ASTM Standards* volume information, refer to the standard's Document Summary page on the ASTM website.

[D6708 Practice for Statistical Assessment and Improvement of Expected Agreement Between Two Test Methods that Purport to Measure the Same Property of a Material](#)

[D6751 Specification for Biodiesel Fuel Blend Stock \(B100\) for Middle Distillate Fuels](#)

[2.2 Energy Institute Standards:³](#)

[IP219 Test Method for Cloud Point of Petroleum Products](#)

3. Terminology

3.1 Definitions:

3.1.1 *biodiesel, n*—fuel comprised of mono-alkyl esters of long chain fatty acids derived from vegetable oils or animal fats, designated B100.

3.1.1.1 *Discussion*—Biodiesel is typically produced by a reaction of a vegetable oil or animal fat with an alcohol such as methanol or ethanol in the presence of a catalyst to yield mono-alkyl esters and glycerin, which is removed. The finished biodiesel derives approximately 10 % of its mass from the reacted alcohol. The alcohol used in the reaction may or may not come from renewable resources.

3.1.2 *biodiesel blend (BXX), n*—a homogeneous mixture of hydrocarbon oils and mono-alkyl esters of long chain fatty acids.

3.1.2.1 *Discussion*—In the abbreviation, BXX, the XX represents the volume percentage of biodiesel fuel in the blend.

3.1.2.2 *Discussion*—The mono-alkyl esters of long chain fatty acids (that is, biodiesel) used in the mixture shall meet the requirements of Specification [D6751](#).

3.1.2.3 *Discussion*—Diesel fuel, fuel oil, and non-aviation gas turbine oil are examples of hydrocarbon oils.

3.1.3 *biodiesel fuel, n*—synonym for biodiesel.

3.1.4 *cloud point, n*—in petroleum products and biodiesel fuels, the temperature of a liquid specimen when the smallest observable cluster of wax crystals first occurs upon cooling under prescribed conditions.

3.1.4.1 *Discussion*—The cloud point occurs when the temperature of the specimen is low enough to cause wax crystals to precipitate. In a homogeneous liquid, the cloud is always

³ Available from Energy Institute, 61 New Cavendish St., London, WIG 7AR, U.K., <http://www.energyinst.org.uk>.

*A Summary of Changes section appears at the end of this standard

noted first at the location in the specimen where the specimen temperature is the lowest. The cloud point is the temperature at which the crystals first occur, regardless of their location in the specimen, and not after extensive crystallization has taken place. The wax crystals that precipitate at lower temperatures are typically, but not excluded to, straight-chain hydrocarbons and lipids.

3.2 Definitions of Terms Specific to This Standard:

3.2.1 *small test jar method, n*—in cloud point test methods, automatic test procedure using a small sample size, prescribed cooling rate, specimen receptacle, and optical system for detection of crystal formation.

3.2.1.1 *Discussion*—The prescribed cooling rate is described in 11.4, the specimen receptacle is described in 6.3, and the optical system for detection of crystal formation is described in A1.2.3.

3.2.2 *D2500/IP219 equivalent cloud point, n*—temperature of a specimen, in integers, calculated by applying a bias and rounding the results of this test method to the next lower integer (see 12.2).

3.2.2.1 *Discussion*—This test method produces results with 0.1 °C resolution. Should the user wish to provide results with a similar format to Test Method D2500, then this calculation can be performed. Some apparatus can perform this calculation automatically.

4. Summary of Test Method

4.1 After inserting the glass test jar containing the specimen into the automatic apparatus and initiating the test program, the specimen is heated, if necessary, to the designated temperature and then cooled by prescribed rates. (See 11.4.) The test specimen is continuously monitored for appearance of hydrocarbon crystals with a light emitter and a light receiver through coaxial-type optical fibers. (See A1.2.3.) When the crystallization in the specimen is detected by the optical system, the temperature is recorded to 0.1 °C resolution. The specimen is then heated to facilitate the start of the next test.

5. Significance and Use

5.1 The cloud point of petroleum products and biodiesel fuels is an index of the lowest temperature of their utility for certain applications. Wax crystals of sufficient quantity can plug filters used in some fuel systems.

5.2 Petroleum blending operations require precise measurement of the cloud point.

5.3 This test method can determine the temperature of the test specimen at which wax crystals have formed sufficiently to be observed as a cloud with a resolution of 0.1 °C.

5.4 This test method provides results that, when corrected for bias and rounded to the next lower integer (see 12.2), have been found equivalent to Test Method D2500.

5.5 This test method determines the cloud point in a shorter time period than required by Test Method D2500.

6. Apparatus

6.1 *Automatic Apparatus*—The automatic cloud point apparatus described in this test method is a microprocessor-

controlled apparatus that is capable of heating and cooling a test specimen at prescribed rates, optically observing the first appearance of hydrocarbon wax crystals, and recording the temperature of the test specimen. A detailed description of the apparatus is provided in Annex A1.

6.2 *Temperature-Measuring Device*—The temperature-measuring device in the specimen chamber shall be capable of measuring the temperature from –65 °C to 51 °C at a resolution of 0.1 °C.

6.3 *Test Jar*—Clear, cylindrical borosilicate glass with a flat bottom with an approximate capacity of 12 mL. Approximately 4.5 mL of sample specimen is contained when filled to the scribed line. During the test, the test jar is fitted with a test jar cap assembly on its top. See A1.1.2 for more details on the test jar.

6.4 *Metallic Block Bath*—Metallic block with a cylindrical hole to fit the test jar. The metallic block assembly shall have a provision for cooling/heating. A temperature sensor is embedded in the metallic block to monitor its temperature.

7. Reagents and Materials

7.1 *Cleaning Agents*—Capable of cleaning and drying the test jar and test jar cap assembly, after each test. Chemical agents such as alcohol and petroleum-based solvents have been found suitable to use. (**Warning**—Flammable.) (**Warning**—May be harmful by itself or when evaporated.)

8. Sampling

8.1 Obtain a sample in accordance with Practice D4057 or by Practice D4177.

8.2 A minimum volume of 4.5 mL of sample is required for each test.

8.3 Samples of very viscous materials may be warmed until they are reasonably fluid before they are tested. However, no sample should be heated more than is absolutely necessary to facilitate pouring the sample into the instrument test jar. (**Warning**—Exercise care when selecting the preheating temperature. Samples which are fluid at ambient room temperature can also have a low flash point. Use higher preheating temperatures only on samples known to be solid near ambient room temperature.)

8.4 The sample shall not be heated above 60 °C. When the sample is heated above 60 °C allow the sample to cool below 60 °C before filtering or inserting into the apparatus.

8.5 When moisture is present, remove the moisture by a method such as filtration through dry, lint-free filter paper until the oil is perfectly clear, but make such filtration at a temperature at least 14 °C above the expected cloud point.

NOTE 1—Moisture will be noticed in the sample as a separate phase or as a haze throughout the entire sample. Generally, a slight haze will not interfere with the detection of the wax cloud.

9. Preparation of Apparatus

9.1 Prepare the instrument for operation in accordance with the manufacturer's instructions.

10. Calibration and Standardization

10.1 Ensure that all of the manufacturer's instructions for calibrating, checking, and operating the apparatus are followed.

10.2 A sample with a well-documented cloud point can be used to verify the performance of the automatic apparatus. Alternatively, a sample that has been extensively tested in a cloud point cross-check program can be used. Such verification materials can also be prepared from intracompany cross-checks.

11. Procedure

11.1 Pour the sample specimen into the test jar to the scribed mark. When necessary, heat the sample in a bath or oven until it is just sufficiently fluid to pour into the test jar. Samples with an expected cloud point above 36 °C or samples which appear solid at room temperature can be heated above 45 °C, but they shall not be heated above 60 °C.

11.2 Insert the charged test jar into the metallic block bath, and install the test jar cap assembly snugly.

11.3 Enter the expected cloud point and start the operation of the apparatus according to the manufacturer's instructions. From this point on, the apparatus automatically controls the series of procedures, which includes the sample preheating function if the apparatus is so programmed prior to the start of the automatic procedure. (**Warning**—Exercise care when selecting the preheating temperature. Samples which are fluid at ambient room temperature can also have a low flash point. Use higher preheating temperatures only on samples known to be solid near ambient room temperature.)

11.4 After the sample preheating is completed, the metallic block bath is cooled down automatically at a typical rate of 3 °C to 4 °C/min. At a temperature at least 20 °C above the expected cloud point, the cooling rate slows down to 0.8 °C to 1.1 °C/min. During the cooling, the optical system monitors for appearance of the crystals.

11.5 In the event a cloud point is detected prematurely during the fast cooling rate, as determined by the apparatus, the specimen shall be reheated to a higher temperature, at least 30 °C warmer than the temperature of premature detection, and then cooled as described in 11.4, while the optical system monitors for appearance of the crystals.

11.6 At the detection of the cloud point, the specimen temperature is displayed to the nearest 0.1 °C and held on the digital display. The metallic block bath starts heating automatically for the next test.

12. Report

12.1 Report the temperature recorded in 11.6 to 0.1 °C as the cloud point D7683 (Small Test Jar Method).

12.2 When specified, correct the results recorded in 11.6 with the relative bias in accordance with 13.3, then round to the next lower integer (a colder temperature) and report as the Test Method D2500 equivalent cloud point in accordance with Test Method D7683.

13. Precision and Bias⁴

13.1 *Precision*—The precision of this test method as determined by the statistical examination of the interlaboratory test results is as follows:

13.1.1 *Repeatability*—The difference between successive test results, obtained by the same operator using the same apparatus under constant operating conditions on identical test material, would in the long run, in the normal and correct operation of this test method, exceed the following only in one case in twenty.

1.47 °C, valid range –50 °C to +6 °C

13.1.2 *Reproducibility*—The difference between two single and independent test results, obtained by different operators working in different laboratories on identical test material, would in the long run, in normal and correct operation of this test method, exceed the following only in one case in twenty.

2.45 °C, valid range –50 °C to +6 °C

13.2 *Bias*—Since there is no accepted reference material suitable for determining the bias for the procedure in this test method, bias has not been determined.

13.3 *Relative Bias*—The Degree of Agreement between results by Test Method D7683 and Test Method D2500/IP219—Results on the same materials produced by Test Method D7683 and Test Method D2500 have been assessed in accordance with procedures outlined in Practice D6708. The findings are:

The degree of agreement between results from Test Method D7683 and Test Method D2500/IP219 can be further improved by applying the bias correction outlined in Eq 1. Sample-specific bias, as defined in Practice D6708, was observed for some samples after applying the bias correction.

$$\text{Predicted } Y(\text{D2500}) = \text{bias} - \text{corrected } X(\text{D7683}) = X(\text{D7683}) + 1.68^\circ\text{C} \quad (1)$$

where:

X = result obtained by Test Method D7683, and
bias-corrected X = predicted Y = result that would have been obtained by Test Method D2500/IP219 on the same sample.

Differences between bias-corrected results from Eq 1 and Test Method D2500/IP219, for the sample types and property ranges studied, are expected to exceed the following between method reproducibility (R_{XY}), as defined in Practice D6708, about 5 % of the time.

$$R_{XY} = 3.51^\circ\text{C} \quad (2)$$

13.4 The precision statements were derived from a 2009 interlaboratory cooperative test program.⁴ Participants analyzed 21 sample sets comprised of six distillate fuels, six base oil stocks, three biodiesel (derived from soy, canola, and tallow), and six blends of biodiesel in distillate fuel representing B5, B10, and B20 blends. The cloud point temperature

⁴ Supporting data have been filed at ASTM International Headquarters and may be obtained by requesting Research Report RR:D02-1715. Contact ASTM Customer Service at service@astm.org.

range was $-50\text{ }^{\circ}\text{C}$ to $6\text{ }^{\circ}\text{C}$. There were twelve laboratories that participated with the small test jar method automatic instrument and twelve laboratories participated with the manual D2500/IP219 test method. Information on the type of samples and their average cloud points are in the research report available at ASTM Headquarters.⁴

14. Keywords

14.1 automated cloud point; biodiesel; cloud point; petroleum products

ANNEX

(Mandatory Information)

A1. AUTOMATIC SMALL TEST JAR METHOD CLOUD POINT APPARATUS

A1.1 General

A1.1.1 The microprocessor controlled test apparatus is described in this annex and illustrated in Fig. A1.1.

A1.1.2 *Test Jar*—Clear, cylindrical borosilicate glass with a flat bottom, $21\text{ mm} \pm 0.2\text{ mm}$ outside diameter, $45\text{ mm} \pm 0.5\text{ mm}$ height, and $1\text{ mm} \pm 0.2\text{ mm}$ wall thickness. A scribed line is permanently marked at $16\text{ mm} \pm 0.3\text{ mm}$ from the outside bottom of the jar. A round aluminum foil disc is attached to the outside bottom surface for optical cloud point detection.

A1.2 Test Jar Cap Assembly

A1.2.1 *Plastic Test Jar Cap*—With a provision to make the test jar airtight.

A1.2.2 *Temperature Sensor*—Such as platinum resistance probe in a small diameter stainless steel sheath, typically 2 mm in outside diameter, to read the specimen temperature to $0.1\text{ }^{\circ}\text{C}$. It should be placed in the center of the test jar, and its lower end should be positioned 1 mm above the test jar.

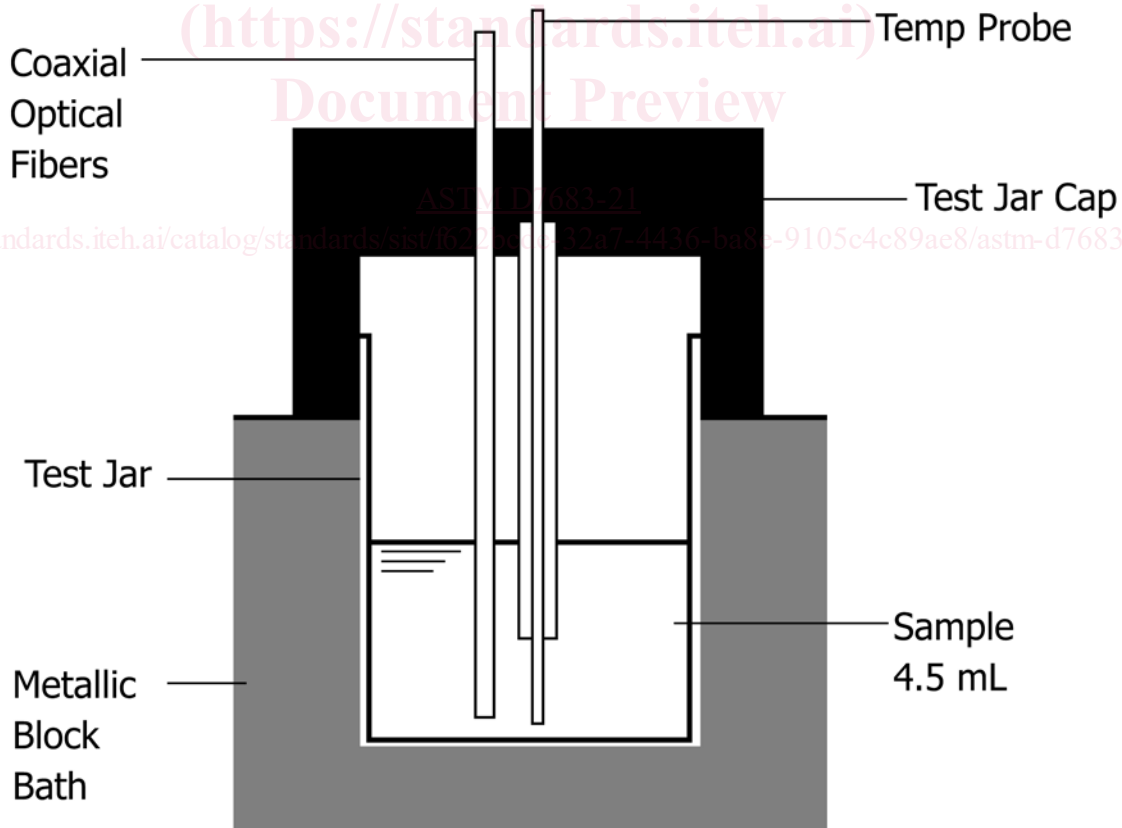

FIG. A1.1 Principle of Apparatus