



SLOVENSKI STANDARD
SIST EN 12697-19:2004
01-september-2004

6]li a Ybg_Y'na Ygj'É'DfYg_i gbY'a YfcXY'nU'j fc Y'UgZU'fbY'na Ygj'É'% "XY.
DfYdi gHbcghidfYg_i yUbW'j

Bituminous mixtures - Test methods for hot mix asphalt - Part 19: Permeability of specimen

Asphalt - Prüfverfahren für Heißasphalt - Teil 19: Durchlässigkeit von Probekörpern

Mélanges bitumineux - Méthodes d'essai pour mélange hydrocarboné a chaud - Partie 19: Perméabilité des éprouvettes

Ta slovenski standard je istoveten z: EN 12697-19:2004
SIST EN 12697-19:2004
<https://standards.iteh.ai/catalog/standards/sist/0619457-a270-41c1-b755-c180696b2b78/sist-en-12697-19-2004>

ICS:

93.080.20 Materiali za gradnjo cest Road construction materials

SIST EN 12697-19:2004 **en**

iTeh STANDARD PREVIEW
(standards.iteh.ai)

SIST EN 12697-19:2004

<https://standards.iteh.ai/catalog/standards/sist/b6ff9457-a290-41c1-b755-c180696b2b78/sist-en-12697-19-2004>

ICS 93.080.20

English version

Bituminous mixtures - Test methods for hot mix asphalt - Part
19: Permeability of specimen

Mélanges bitumineux - Méthodes d'essai pour mélange
hydrocarboné à chaud - Partie 19: Perméabilité des
éprouvettes

Asphalt - Prüfverfahren für Heiasphalt - Teil 19:
Durchlssigkeit von Probekrpern

This European Standard was approved by CEN on 24 March 2004.

CEN members are bound to comply with the CEN/CENELEC Internal Regulations which stipulate the conditions for giving this European Standard the status of a national standard without any alteration. Up-to-date lists and bibliographical references concerning such national standards may be obtained on application to the Central Secretariat or to any CEN member.

This European Standard exists in three official versions (English, French, German). A version in any other language made by translation under the responsibility of a CEN member into its own language and notified to the Central Secretariat has the same status as the official versions.

CEN members are the national standards bodies of Austria, Belgium, Cyprus, Czech Republic, Denmark, Estonia, Finland, France, Germany, Greece, Hungary, Iceland, Ireland, Italy, Latvia, Lithuania, Luxembourg, Malta, Netherlands, Norway, Poland, Portugal, Slovakia, Slovenia, Spain, Sweden, Switzerland and United Kingdom.

SIST EN 12697-19:2004

<https://standards.iteh.ai/catalog/standards/sist/b6ff9457-a290-41c1-b755-c180696b2b78/sist-en-12697-19-2004>



EUROPEAN COMMITTEE FOR STANDARDIZATION
COMITÉ EUROPÉEN DE NORMALISATION
EUROPÄISCHES KOMITEE FÜR NORMUNG

Management Centre: rue de Stassart, 36 B-1050 Brussels

Contents

page

Foreword.....	3
1 Scope	6
2 Normative references	6
3 Principle.....	6
4 Vertical permeability.....	6
4.1 General.....	6
4.2 Apparatus for vertical permeability	6
4.3 Procedure	6
4.4 Calculation.....	8
5 Horizontal permeability	8
5.1 General.....	8
5.2 Apparatus for horizontal permeability.....	8
5.3 Procedure	9
5.4 Calculation.....	10
6 Test report	11
6.1 General.....	11
6.2 Information on specimen	11
6.3 Information on the test and results.....	11
7 Precision.....	11

[SIST EN 12697-19:2004
https://standards.iteh.ai/catalog/standards/sist/b6ff9457-a290-41c1-b755-c180696b2b78/sist-en-12697-19-2004](https://standards.iteh.ai/catalog/standards/sist/b6ff9457-a290-41c1-b755-c180696b2b78/sist-en-12697-19-2004)

Foreword

This document (EN 12697-19:2004) has been prepared by Technical Committee CEN/TC 227 "Road materials", the secretariat of which is held by DIN.

This European Standard shall be given the status of a national standard, either by publication of an identical text or by endorsement, at the latest by January 2005, and conflicting national standards shall be withdrawn at the latest by January 2005.

This document is one of a series of standards as listed below:

EN 12697-1, *Bituminous mixtures — Test methods for hot mix asphalt — Part 1: Soluble binder content.*

EN 12697-2, *Bituminous mixtures — Test methods for hot mix asphalt — Part 2: Determination of particle size distribution.*

EN 12697-3, *Bituminous mixtures — Test methods for hot mix asphalt — Part 3: Bitumen recovery: Rotary evaporator.*

EN 12697-4, *Bituminous mixtures — Test methods for hot mix asphalt — Part 4: Bitumen recovery: Fractionating column.*

EN 12697-5, *Bituminous mixtures — Test methods for hot mix asphalt — Part 5: Determination of the maximum density.*

EN 12697-6, *Bituminous mixtures — Test methods for hot mix asphalt — Part 6: Determination of bulk density of bituminous specimens.*

EN 12697-7, *Bituminous mixtures — Test methods for hot mix asphalt — Part 7: Determination of bulk density of bituminous specimens by gamma rays.*

EN 12697-8, *Bituminous mixtures — Test methods for hot mix asphalt — Part 8: Determination of void characteristics of bituminous specimens.*

EN 12697-9, *Bituminous mixtures — Test methods for hot mix asphalt — Part 9: Determination of the reference density.*

EN 12697-10, *Bituminous mixtures — Test methods for hot mix asphalt — Part 10: Compactability.*

EN 12697-11, *Bituminous mixtures — Test methods for hot mix asphalt — Part 11: Determination of the affinity between aggregate and bitumen.*

EN 12697-12, *Bituminous mixtures — Test methods for hot mix asphalt — Part 12: Determination of the water sensitivity of bituminous specimens.*

EN 12697-13, *Bituminous mixtures — Test methods for hot mix asphalt — Part 13: Temperature measurement.*

EN 12697-14, *Bituminous mixtures — Test methods for hot mix asphalt — Part 14: Water content.*

EN 12697-15, *Bituminous mixtures — Test methods for hot mix asphalt — Part 15: Determination of the segregation sensitivity.*

EN 12697-16, *Bituminous mixtures — Test methods for hot mix asphalt — Part 16: Abrasion by studded tyres.*

EN 12697-19:2004 (E)

EN 12697-17, *Bituminous mixtures — Test methods for hot mix asphalt — Part 17: Particle loss of porous asphalt specimen.*

EN 12697-18, *Bituminous mixtures — Test methods for hot mix asphalt — Part 18: Binder drainage.*

EN 12697-19, *Bituminous mixtures — Test methods for hot mix asphalt — Part 19: Permeability of specimen.*

EN 12697-20, *Bituminous mixtures — Test methods for hot mix asphalt — Part 20: Indentation using cube or Marshall specimens.*

EN 12697-21, *Bituminous mixtures — Test methods for hot mix asphalt — Part 21: Indentation using plate specimens.*

EN 12697-22, *Bituminous mixtures — Test methods for hot mix asphalt — Part 22: Wheel tracking.*

EN 12697-23, *Bituminous mixtures — Test methods for hot mix asphalt — Part 23: Determination of the indirect tensile strength of bituminous specimens.*

EN 12697-24, *Bituminous mixtures — Test methods for hot mix asphalt — Part 24: Resistance to fatigue.*

prEN 12697-25, *Bituminous mixtures — Test methods for hot mix asphalt — Part 25: Cyclic compression test.*

EN 12697-26, *Bituminous mixtures — Test methods for hot mix asphalt — Part 26: Stiffness.*

EN 12697-27, *Bituminous mixtures — Test methods for hot mix asphalt — Part 27: Sampling.*

EN 12697-28, *Bituminous mixtures — Test methods for hot mix asphalt — Part 28: Preparation of samples for determining binder content, water content and grading.*

EN 12697-29, *Bituminous mixtures — Test method for hot mix asphalt — Part 29: Determination of the dimensions of a bituminous specimen.*

EN 12697-30, *Bituminous mixtures — Test methods for hot mix asphalt — Part 30: Specimen preparation, impact compactor.*

EN 12697-31, *Bituminous mixtures — Test methods for hot mix asphalt — Part 31: Specimen preparation by gyratory compactor.*

EN 12697-32, *Bituminous mixtures — Test methods for hot mix asphalt — Part 32: Laboratory compaction of bituminous mixtures by vibratory compactor.*

EN 12697-33, *Bituminous mixtures — Test methods for hot mix asphalt — Part 33: Specimen prepared by roller compactor.*

EN 12697-34, *Bituminous mixtures — Test methods for hot mix asphalt — Part 34: Marshall test.*

prEN 12697-35, *Bituminous mixtures — Test methods for hot mix asphalt — Part 35: Laboratory mixing.*

EN 12697-36, *Bituminous mixtures — Test methods for hot mix asphalt — Part 36: Determination of the thickness of a bituminous pavement.*

EN 12697-37, *Bituminous mixtures — Test methods for hot mix asphalt — Part 37: Hot sand test for the adhesivity of binder on precoated chippings for HRA.*

EN 12697-38, *Bituminous mixtures — Test methods for hot mix asphalt — Part 38: Common equipment and calibration.*

prEN 12697-39, *Bituminous mixtures — Test methods for hot mix asphalt — Part 39: Binder content by ignition.*

prEN 12697-40, *Bituminous mixtures — Test methods for hot mix asphalt — Part 40: In-situ drainability.*

prEN 12697-41, *Bituminous mixtures — Test methods for hot mix asphalt — Part 41: Resistance to de-icing fluids.*

prEN 12697-42, *Bituminous mixtures — Test methods for hot mix asphalt — Part 42: Amount of foreign matters in reclaimed asphalt.*

prEN 12697-43, *Bituminous mixtures — Test methods for hot mix asphalt — Part 43: Resistance to fuel.*

No existing European Standard is superseded.

According to the CEN/CENELEC Internal Regulations, the national standards organizations of the following countries are bound to implement this European Standard: Austria, Belgium, Cyprus, Czech Republic, Denmark, Estonia, Finland, France, Germany, Greece, Hungary, Iceland, Ireland, Italy, Latvia, Lithuania, Luxembourg, Malta, Netherlands, Norway, Poland, Portugal, Slovakia, Slovenia, Spain, Sweden, Switzerland and United Kingdom.

iTeh STANDARD PREVIEW (standards.iteh.ai)

[SIST EN 12697-19:2004](https://standards.iteh.ai/catalog/standards/sist/b6ff9457-a290-41c1-b755-c180696b2b78/sist-en-12697-19-2004)

<https://standards.iteh.ai/catalog/standards/sist/b6ff9457-a290-41c1-b755-c180696b2b78/sist-en-12697-19-2004>

1 Scope

This document describes a method for determining the vertical and horizontal permeability of cylindrical specimens of bituminous mixtures. The standard applies to specimens cored out of the road, specimens from laboratory made slabs or laboratory specimens prepared with a compaction device provided the thickness of the specimen is not less than 2,5 times the nominal maximum particle size of the aggregate in the mixture. The nominal diameter of specimens should be either 100 mm or 150 mm unless the nominal maximum particle size of the aggregate size exceeds 22 mm, when the nominal diameter shall be 150 mm diameter.

2 Normative references

The following referenced document is indispensable for the application of this document. For dated references, only the edition cited applies. For undated references, the latest edition of the referenced document (including any amendments) applies.

EN 12697-29, *Bituminous mixtures — Test methods for hot mix asphalt — Part 29: Determination of the dimensions of a bituminous specimen.*

3 Principle

A column of water with a constant height is applied to a cylindrical specimen and is allowed to permeate through the specimen for a controlled time in either a vertical or horizontal direction depending upon the parameter being measured. The resultant flow rate of the water Q_v or Q_h is a calculated measure of the permeability value K_v or K_h . The test is carried out at ambient temperature.

NOTE When the void content of the same specimen is determined the relationship between permeability and void content can be established.

4 Vertical permeability

4.1 General

In this method, only the water flow in a vertical direction through the specimen is measured.

4.2 Apparatus for vertical permeability

Apparatus as shown in Figure 1. The dimensions shall be such as to ensure the water column height is (300 ± 1) mm. The external diameter of the tube shall be greater than the diameter of the specimen by up to 5 mm and the maximum thickness of the tube wall shall be limited to 5 mm.

A balance with suitable capacity and capable of weighing to the nearest 0,5 g.

4.3 Procedure

4.3.1 Determine the dimensions of the specimen, to the nearest millimetre, according to EN 12697-29. The thickness shall be greater than 25 % of the diameter and greater than twice the nominal maximum aggregate size of the mixture.

4.3.2 If the specimen is trimmed by saw cutting, it shall be cleaned prior to testing, to prevent restriction of the water flow.

- 4.3.3** The test shall be carried out at ambient temperature within the ranges of 15 °C to 25 °C and shall be monitored and recorded. Place the specimen in a rubber cuff. Insert a plastic tube in the cuff and place it on top of the specimen. Carefully inflate the rubber cuff with air to at least 50 kPa, so that it presses firmly around the wall of the specimen to prevent leakage of water along the wall.

Dimensions in millimetres

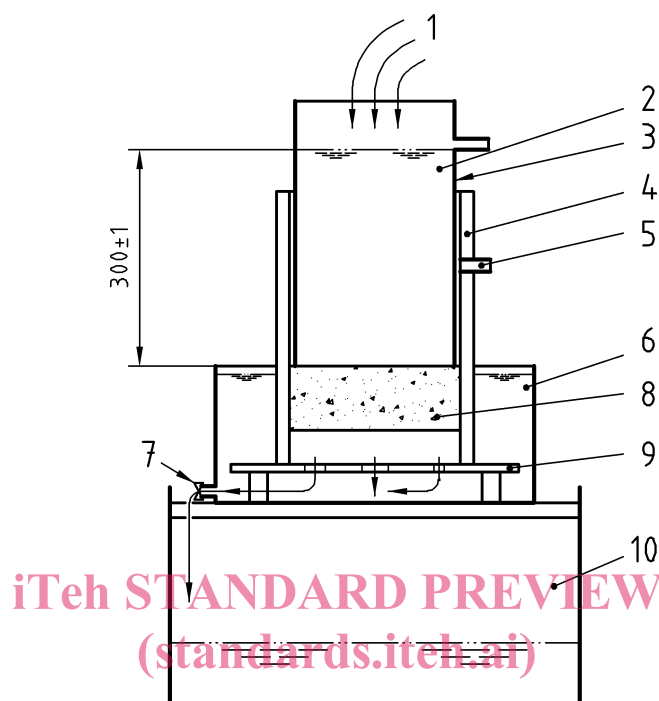

iTeh STANDARD PREVIEW
(standards.iteh.ai)

SIST EN 12697-19:2004

<https://standards.iteh.ai/catalog/standards/sist/b6ff9457-a290-41c1-b755-c180696b2b78/sist-en-12697-19-2004>

Key

- | | | | |
|---|----------------|----|------------------------|
| 1 | Water supply | 6 | Container |
| 2 | Water column | 7 | Outlet valve |
| 3 | Plastic tube | 8 | Specimen |
| 4 | Rubber cuff | 9 | Perforated plate |
| 5 | Overflow valve | 10 | Second collection tank |

Figure 1 — Apparatus for vertical permeability

4.3.4 Place the cuff with the specimen on a perforated plate and place it in a container that is filled with water to the maximum level. Adjust the feet of the perforated plate in such a way that the upper side of the specimen is at the same level as the water in the bath. Allow the water to flow into the specimen for approximately 10 min. After this time it is assumed that the specimen is saturated with water and all enclosed air is removed.

4.3.5 Fill the plastic tube with water. There is an outlet in the plastic tube, so that a water column height of (300 ± 1) mm is always maintained.

4.3.6 Allow the water to flow through the specimen. The container shall be equipped with an outlet valve which leads into a weighed empty container m_1 . After about 1 min, open the valve in the container and collect the water that flows through into the weighed second container for a certain time t , minimum 60 s. After the time t weigh the second container together with the collected water m_2 .

NOTE At a voids content of about 20 %, the vertical flow of water is about 3 l/min to 10 l/min. It should be noted, however, that when the test is carried out on a core taken from the road surface, the surface can be somewhat clogged and although still retaining 20 % voids may not have a flow in this range.

4.3.7 Repeat the test on the same specimen.