



Designation: D5507 – 21

# Standard Test Method for Determination of Trace Organic Impurities in Monomer Grade Vinyl Chloride by Capillary Column/Multidimensional Gas Chromatography<sup>1</sup>

This standard is issued under the fixed designation D5507; the number immediately following the designation indicates the year of original adoption or, in the case of revision, the year of last revision. A number in parentheses indicates the year of last reapproval. A superscript epsilon ( $\epsilon$ ) indicates an editorial change since the last revision or reapproval.

## 1. Scope\*

1.1 This is a general-purpose capillary-based test method for the determination of trace level impurities in high-purity vinyl chloride. This test method uses serially coupled capillary PLOT columns in conjunction with the multidimensional techniques of column switching and cryogenic trapping to permit the complete separation of the 11 key vinyl chloride impurities in a single 25-min run.

NOTE 1—There is no known ISO equivalent to this standard.

1.2 *This standard does not purport to address all of the safety concerns, if any, associated with its use. It is the responsibility of the user of this standard to establish appropriate safety, health, and environmental practices and determine the applicability of regulatory limitations prior to use.* Specific hazards statements are given in Section 8.

1.3 *This international standard was developed in accordance with internationally recognized principles on standardization established in the Decision on Principles for the Development of International Standards, Guides and Recommendations issued by the World Trade Organization Technical Barriers to Trade (TBT) Committee.*

## 2. Referenced Documents

2.1 *ASTM Standards:*<sup>2</sup>

**D883 Terminology Relating to Plastics**

**D1600 Terminology for Abbreviated Terms Relating to Plastics**

**F307 Practice for Sampling Pressurized Gas for Gas Analysis**

## 3. Terminology

3.1 *Definitions*—Terminology is in accordance with Terminologies **D883** and **D1600** unless otherwise indicated.

<sup>1</sup> This test method is under the jurisdiction of ASTM Committee **D20** on Plastics and is the direct responsibility of Subcommittee **D20.70** on Analytical Methods.

Current edition approved Jan. 15, 2021. Published January 2021. Originally approved in 1994. Last previous edition approved in 2012 as D5507 – 99(2012). DOI: 10.1520/D5507-21.

<sup>2</sup> For referenced ASTM standards, visit the ASTM website, www.astm.org, or contact ASTM Customer Service at service@astm.org. For *Annual Book of ASTM Standards* volume information, refer to the standard's Document Summary page on the ASTM website.

## 4. Summary of Test Method

4.1 The liquid vinyl chloride sample or calibration standard is injected either directly using a high-pressure liquid sampling valve or alternately as an expanded gas. An appropriate volume of the liquid or gas sample is injected to enable the required detection limits to be achieved. A preliminary GC separation is achieved on a 6-m pre-column, the purpose of which is to remove the bulk of the vinyl chloride peak from the trace peaks of interest. Two heart-cut transfers are made from this pre-column separation, which sends selected portions to a second column for additional separation. These two cuts incorporate 10 of the 11 trace impurities of interest, but they exclude 1,2 ethylene dichloride and the bulk of the vinyl chloride peak. The 1,2 EDC peak is eluted from the 6-m pre-column and detected at the first FID after the two cuts are made.

4.2 The components eluting to the two FID detectors are identified and quantitated by comparing their retention times and area counts to those obtained previously from a calibration standard run under identical conditions.

## 5. Significance and Use

5.1 The multidimensional approach permits all of the trace impurities to be well separated from the main vinyl chloride peak, thereby improving quantitative accuracy over established packed column methods.

5.2 The minimum detection limit (MDL) for all components of interest has been shown to be well below 500 ppb for this test method.

## 6. Apparatus

6.1 *Instrumentation:*

6.1.1 *Capillary Column/Multidirectional Gas Chromatograph*, equipped as follows:

6.1.1.1 *Split/Splitless Injector System*—Must be demonstrated to be free of discrimination effects induced by vapor viscosity differences if helium- or nitrogen-based gas standards are to be used for instrument calibration.

6.1.1.2 *Dual Flame-Ionization Detectors.*

6.1.1.3 *Column Switching Device* A pneumatics control system.

\*A Summary of Changes section appears at the end of this standard

LPG VAPORIZING INJECTOR

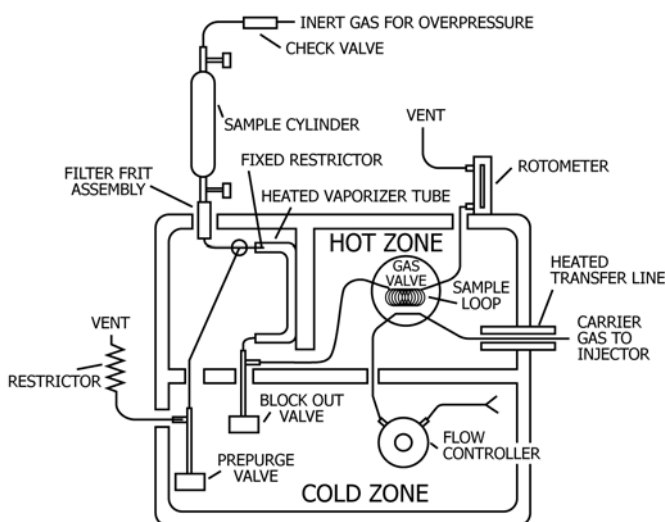

FIG. 1 Procedure B: On-Line Vaporization Using the LPG Vaporizing Injector

concentrations of the various components in this standard should also represent typical values expected for the particular process or sample. The following is a typical calibration standard composition:

Component	Mole, ppm	Weight, ppm
Ethylene	29.4	13.2
Propylene	20.0	13.5
Acetylene	6.8	2.8
Butane-1	6.8	6.1
Trans-butene-2	7.1	6.4
Cis-butene-2	7.5	6.7
1,3 butadiene	6.5	5.6
Methyl chloride	36.8	29.7
Vinyl acetylene	12.2	10.2
Ethyl chloride	15.9	16.4
1,2 ethylene dichloride	11.8	18.7
Nitrogen	balance	

7.5.2 Secondary Standard—The secondary standard is a vinyl chloride-based blend, which is used for method setup and day-to-day method calibration. This standard is prepared from actual vinyl chloride product, which is spiked where appropriate to yield the approximate levels represented in the nitrogen-based primary standard. The final concentrations should be determined by averaging the results from multiple runs, which are referenced to the primary standard. This calibration/recalibration process may be conducted using an alternate GC procedure.

8. Hazards

8.1 Appropriate caution must be exercised in handling the sample due to the suspected carcinogenicity of vinyl chloride. Any excess of sample beyond that actually injected into the column should be routed to a purge waste line to be passed to a vent hood or other suitable disposal location. This excess sample includes the inlet splitter vent flow and the sample-loop purge flow in the case in which a gas-valve injection is being made.

9. Sampling

9.1 This section is to be followed for all samples, including unknown samples and the synthetic standards.

9.2 Samples should be supplied to the laboratory in high-pressure sample cylinders, obtained using the procedure described in Practice F307 or similar standards.

9.3 Place the cylinder in a horizontal position in a safe place such as a hood. Check to see that the container is at least one-half full by opening the valve slightly. The container is at least one-half full if liquid is emitted (a white cloud of vapors). Do not analyze any samples or use any synthetic standard if the liquid in the container is below this amount.

9.4 Place the cylinder in a vertical position and repressure to 1.208 MPa (175 psig) with the chromatographic carrier or equivalent inert gas through the valve at the top of the cylinder, ensuring that no air enters during the operation.

9.5 Use either of the following two procedures for obtaining a sample from the container:

9.5.1 Liquid Sample—Connect the cylinder to the liquid valve on the chromatograph using a minimum length of connecting tubing, so that sample is withdrawn from the

- 6.1.1.4 Sub-Ambient Oven Temperature Control (optional).
- 6.1.1.5 LPG Vaporizing Injector, (Fig. 1).

6.2 Data System, permits the acquisition, storage, and reduction of the output signals from the two FIDs simultaneously. After the initial method development, however, it is possible to consolidate the output to a single integrator using the instruments signal switching capability.

6.3 Columns:

6.3.1 Pre-Column—100 cm of 0.20-mm inside diameter fused silica fixed restrictor coupled to the front of a 6 m by 0.53-mm inside diameter.

6.3.2 Analytical Column—9 m by 0.53-mm inside diameter plus 25 m by 0.53 mm inside diameter.

6.4 Syringes—A range of high-quality gas-tight syringes representing volumes from 0.5 to 25 mL should be available. These syringes should be equipped with PTFE-tipped plunger seals and on and off syringe valves to prevent the loss of gas sample.

7. Reagents and Materials

7.1 Helium—Carrier gas, zero grade, high quality. Traps should be placed in the supply lines leading to the gas chromatograph. These traps should reduce oxygen, moisture, and hydrocarbons to the lowest possible levels.

7.2 Hydrogen—Flame gas, high-purity (hydrocarbon free).

7.3 Air—Flame gas, high-purity (hydrocarbon free).

7.4 Liquid CO<sub>2</sub>—Coolant, bone-dry grade, liquid-delivery, 1200-psi helium pad recommended.

7.5 Standards:

7.5.1 Primary Standard—The primary standard is a certified reference standard, which is blended into a stable nitrogen or helium matrix. The component concentrations should be prepared and reported on an as-in-vinyl chloride basis. The

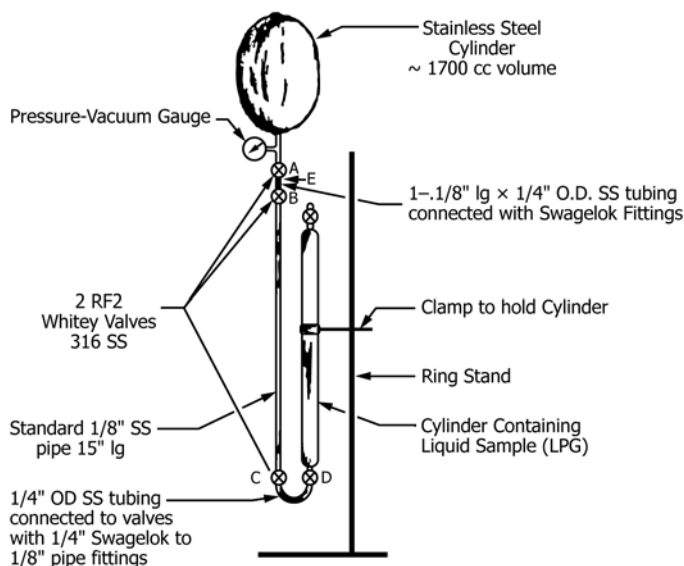

FIG. 2 Procedure A: Off-Line Vaporization

bottom of the cylinder and a liquid sample is obtained. The liquid valve on the chromatograph must be designed in such a manner that full sample pressure can be maintained through the valve without leaking and that means are provided for trapping a liquid sample in the chromatograph valve under static flow conditions. With the exit of the chromatograph valve closed, open the valve on the cylinder. Open the exit from the chromatograph valve slowly so that liquid flows through the connecting line and valve. Close the exits so that the liquid sample is trapped in the valve. Perform the necessary operations to introduce the liquid sample into the chromatograph column.

### 9.5.2 Vaporized Sample:

#### 9.5.2.1 Procedure A—Off-Line Vaporization:

(1) Assemble the apparatus in a manner similar to that illustrated in Fig. 2. Disconnect the 1700-cm<sup>3</sup> cylinder at E and evacuate. Close Valve B and open Valves C and D, allowing the liquid sample to flow into the small cylinder. Open Valve B slowly and allow the sample to flow through until a steady slow stream of liquid emerges from B. Close Valves B, C, and D in that order, trapping a portion of the liquid sample in the pipe cylinder. Attach the evacuated cylinder (1700-cm<sup>3</sup> volume) at E. Open Valve A and then Valve B. The liquid will expand, filling the larger cylinder. Close Valve A and disconnect at E.

NOTE 2—To prevent possible rupture of the liquid-filled pipe cylinder, the sample cylinder and its contents should be at room temperature prior to sampling, and the liquid should be allowed to remain in the pipe cylinder for only a minimum of time.

(2) Connect the cylinder containing the vaporized sample to the chromatograph gas valve. Evacuate the sample loop and the lines up to the sample cylinder. Close the valve to the vacuum source and allow the sample loop to fill with sample up to atmospheric pressure. Repeat the evacuation and filling of the sample loop with vaporized sample. Turn the valve so that the vaporized sample is displaced with carrier gas into the chromatograph.

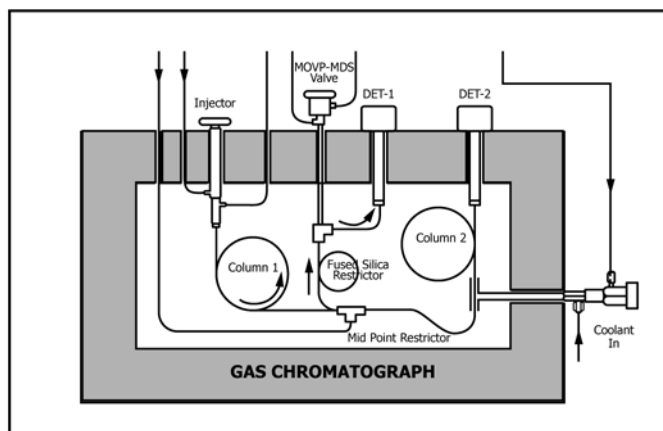

FIG. 3 By-Pass Operation

9.5.2.2 Procedure B—On-line vaporization using the LPG Vaporizing Injector (or equivalent). An alternate approach that has been used successfully for the automated on-line LPG to vapor conversion and sample introduction is shown in Fig. 1. The vapor injection occurs in the upper half of this assembly labeled “hot zone.” The automated injection process proceeds as follows:

(1) The lower valve of the sample cylinder is opened to permit the flow of liquid to the fixed restrictor (35 to 45- $\mu$ m pinpoint restriction or equivalent).

(2) The constant-pressure force above the liquid drives liquid across the fixed restrictor at a constant rate.

(3) The vapor formed in the heated vaporizer tube is mixed prior to passing through the block out valve and on through the sample loop to vent.

(4) The sample loop purge is permitted to proceed for a fixed period of time that is sufficient to ensure a complete purge of the loop volume.

(5) The block out valve automatically shuts off the flow of vapor to the sample loop after the sample-loop purge period.

(6) A short delay period is permitted after sample block out and before sample injection. This delay ensures that the sample loop is permitted to decay back to atmospheric pressure.

(7) The gas sampling valve is then actuated to inject the sample loop contents into the flowing carrier gas stream and simultaneously begin the GC run.

## 10. Preparation of Apparatus

10.1 The column/transfer tube combination is installed as outlined in the schematic shown in Fig. 3 (by-pass operation) and Fig. 4 (heart-cut operation).

### 10.2 Initial Instrument Parameters:

#### 10.2.1 Columns:

10.2.1.1 Pre-Column—100 cm of 0.20-mm inside diameter fused silica fixed restrictor coupled to the front of a 6 m by 0.53-mm inside diameter.

10.2.1.2 Analytical Column—9 m by 0.53-mm inside diameter GSQ<sup>TM</sup> plus 25 m by 0.53 mm inside diameter.

#### 10.2.2 Injection Mode—Split.

#### 10.2.3 Split Ratio—At 1:1.

#### 10.2.4 Split Volume—At 15 mL/min.

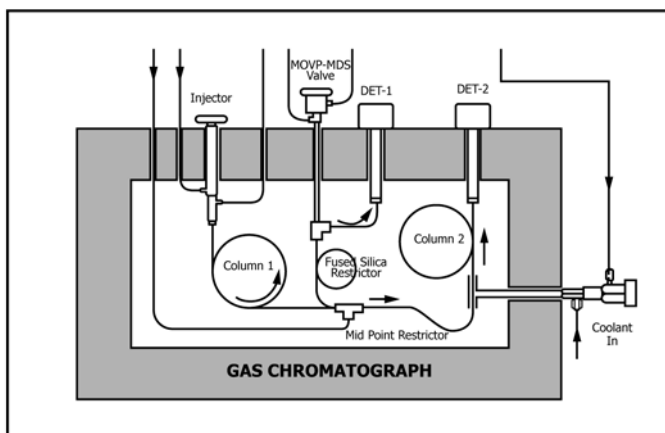

FIG. 4 Heart-Cut Operation

10.2.5 Injection Volume—At 1.00 mL.

10.2.6 Injection Temperature—180°C.

10.2.7 Detector Temperature—240°C.

10.2.8 Column Temperature (Typical):

Ramp 1	40°C initial, 3 min, 7°C/min, 100°C final, 2-min hold
Ramp 2	5°C/min, 135°C final, 0-min hold
Ramp 3	15°C/min, 155°C final, 5-min hold

10.2.9 Carrier Gas:

Pre-column pressure	82.8 kPa (12.0 psi)
Midpoint pressure	55.2 kPa (8.0 psi)

10.2.10 Detectors:

Monitor	FID B—Signal 2
Analytical	FID A—Signal 1

10.2.11 Instrument Gas Pressures:

helium	372.5 kPa (54 psi)
hydrogen	110.4 kPa (16 psi)
air	220.7 kPa (32 psi)

10.2.12 MDGC Event Times (Approximate):

Heart-cut No. 1	0 min 5 s to 4 min 0 s
Cold trap	7 min 0 s to 12 min 15 s
Heart-cut No. 2	8 min 10 s to 11 min 0 s

10.2.13 Fixed Resistor—200- $\mu$ m inside diameter deactivated fused silica 86 cm in length.

10.3 Pressure Balancing—The switching system is then adjusted to a pressure balanced condition using the following procedure:

10.3.1 Equilibrate the GC oven for isothermal operation at 150°C.

10.3.2 With the system operated in the monitor mode (that is, heart-cut valve open and plunger up), a series of 1.0-mL gas injections are made with a sample of high-purity vinyl chloride. The outputs from both detectors should be observed while these test probes are being made.

10.3.3 When the mid-point pressure is set below the balance point, splitting of the test peak will occur at the mid-point restrictor, and responses will be recorded from both detectors.

10.3.4 The mid-point pressure is increased slightly after each such injection until the pressure differential is reached, at which the test peak is absent (or acceptably small) from the second detector. This is the correct pressure differential for normal heart-cut and back flush operations.

10.3.5 This pressure tuning process should be required only once for any combination of columns and restrictors.

10.4 Establishing Column Switching Parameters—The heart-cut and cold-trap times in the instrument parameters (see 10.2) can be used as a general guideline or can be developed from the following procedure:

10.4.1 The process of establishing the heart-cut times for this procedure is begun by determining retention times for the pre-column separation only. This is accomplished by holding the system in the monitor mode while the first complete run is made with the secondary standard. A sample volume of 1.0 to 1.25 mL should be used for this and all subsequent injections.

10.4.2 The retention times from this first run are then used to determine the approximate start and stop times required for heart-cut No. 1. This cut should include all of the trace impurities, which elute prior to the vinyl chloride peak (that is, ethane, ethylene, acetylene, propylene, and methyl chloride). The best results are achieved in practice if the first cut is terminated just into the front edge of the large vinyl chloride peak.

10.4.3 After the times are finalized for the first cut, the last of those tuning runs is used to determine the appropriate times for heart-cut No. 2. This cut includes ethyl chloride and the C<sub>4</sub> unsaturates group (that is, cis-butene-2, trans-butene-2, butene-1, 1,3-butadiene, and vinyl acetylene).

10.4.4 The final step in establishing the MDGC parameters is to select the on and off times for the LCO<sub>2</sub> cold trap operation. These times will be selected on the basis of the start and stop cut times, which were determined for heart-cut No. 2. The cold trap is turned on at 1.5 min prior to the start of cut No. 2 and is turned off at 1.0 min after cut No. 2 is completed.

10.4.5 The system is ready for calibration and sample analysis after the multidimensional parameters have been determined.

## 11. Calibration and Standardization

11.1 Initial Calibration—After the initial setup, it is recommended that 5 to 7 replicate calibration runs be made in succession with the secondary calibration standard. The results from the first run should be discarded, and those from the remaining runs should be used for the determination of response factors, mean area counts, standard deviations, and percent relative standard deviations for each of the trace components. If the variability is found to be within acceptable limits (less than 3 % RSD for all components), the subsequent sample analysis can be conducted. The average response factor for each of the trace components is used for subsequent calculation.

11.2 Continuing Calibration Check—Although the calibration results for this test method have proven to be very stable over long periods of time (days to weeks), it is highly recommended that an instrument-calibration check be made at least once per day, and preferably once per shift. If the response factor for any component is found to vary from the previous calibration by a value greater than 5 %, it will be necessary to re-run the calibration standard or locate the cause of the variation, or both. If no mechanical problems are found (leaks, etc.) to explain the variation and the system is found to be