



# Standard Specification for Stationary Upright and Recumbent Exercise Bicycles and Upper and Total Body Ergometers<sup>1</sup>

This standard is issued under the fixed designation F1250; the number immediately following the designation indicates the year of original adoption or, in the case of revision, the year of last revision. A number in parentheses indicates the year of last reapproval. A superscript epsilon ( $\epsilon$ ) indicates an editorial change since the last revision or reapproval.

## INTRODUCTION

The goal of this specification is to promote proper design and manufacturing practices for stationary upright and recumbent exercise bicycles and ergometers. Through these specifications, this specification aims to assist designers and manufacturers in reducing the possibility of injury when these products are used in accordance with the operational instructions.

The equipment user must recognize, however, that a standard alone will not necessarily prevent injuries. Like other physical activities, exercise involving this equipment involves the risk of injury, particularly if the equipment is used improperly or is not properly maintained. In addition, users with physical limitations should seek medical advice and instruction from the fitness facility prior to using this equipment. Certain physical conditions or limitations may preclude some persons from using this equipment as intended by the manufacturer, and using this equipment may increase the risk of injury.

## 1. Scope

1.1 This standard establishes parameters for the design and manufacture of stationary upright and recumbent exercise bicycles and ergometers as defined in Section 3.

1.2 It is the intent of this standard to specify fitness products for use only by an individual age 13 and older.

1.3 This standard is to be used in conjunction with Specification F2276 and Test Methods F3023.

1.4 This specification is intended to reduce the demonstrated hazards associated with the use of stationary exercise upright and recumbent bicycles and ergometers.

1.5 This specification is written to provide reasonable safety standards for the user of stationary upright and recumbent exercise bicycles and ergometers during storage, movement, entry, use and exit from the product.

1.6 This standard does not apply to mechanisms that convert road bicycles into indoor stationary bicycles.

1.7 This specification<sup>2</sup> establishes additional requirements not set forth in the referenced ASTM standards for the design

of commercial fitness equipment to increase access and user independence by people with functional limitations or impairments.

1.8 The values stated in SI units are to be regarded as standard. The values in parentheses are for information only.

1.9 *This standard does not purport to address all of the safety concerns, if any, associated with its use. It is the responsibility of the user of this standard to establish appropriate safety, health, and environmental practices and determine the applicability of regulatory limitations prior to use.*

1.10 *This international standard was developed in accordance with internationally recognized principles on standardization established in the Decision on Principles for the Development of International Standards, Guides and Recommendations issued by the World Trade Organization Technical Barriers to Trade (TBT) Committee.*

## 2. Referenced Documents

2.1 *ASTM Standards:*<sup>3</sup>

F1749 Specification for Fitness Equipment and Fitness Facility Safety Signage and Labels

F2276 Specification for Fitness Equipment

F3021 Specification for Universal Design of Fitness Equipment for Inclusive Use by Persons with Functional Limitations and Impairments

<sup>1</sup> This safety specification is under the jurisdiction of ASTM Committee F08 on Sports Equipment, Playing Surfaces, and Facilities and is the direct responsibility of Subcommittee F08.30 on Fitness Products.

Current edition approved Dec. 15, 2020. Published February 2021. Originally approved in 1989. Last previous edition approved in 2018 as F1250 – 18. DOI: 10.1520/F1250-20.

<sup>2</sup> This work was funded, in part, by the Rehabilitation Engineering Research Center on RecTech through the National Institute on Disability, Independent Living, and Rehabilitation Research grant #90RE5009-01-00.

<sup>3</sup> For referenced ASTM standards, visit the ASTM website, [www.astm.org](http://www.astm.org), or contact ASTM Customer Service at [service@astm.org](mailto:service@astm.org). For *Annual Book of ASTM Standards* volume information, refer to the standard's Document Summary page on the ASTM website.

**F3023 Test Methods for Evaluating Design and Performance Characteristics of Stationary Upright and Recumbent Exercise Bicycles and Upper and Total Body Ergometers**

**3. Terminology**

3.1 The terms listed below are unique to this specification. For terms not defined below, refer to Specifications F2276 and F3021.

3.2 Definitions:

3.2.1 *back support, n*—part of the user support means that comes in contact with the user’s back during operation.

3.2.2 *consumer exercise bicycle, n*—stationary exercise bicycle intended for use by one person or family unit in a home environment.

3.2.3 *crank, n*—the means that are provided on an exercise bicycle or ergometer to transmit motion from the user’s upper or lower body to the drive axle of the equipment.

3.2.4 *crank handle, n*—a device designed to be held by the hand to rotate the ergometer crank while the user is performing the exercise as intended by the manufacturer.

3.2.5 *cycle, n*—movement of a point or load from a starting position and back to the same starting position, through one complete revolution. This cycle being executed through the full range of intended motion.

3.2.5.1 *Discussion*—In this standard, *cycle* is only used per this definition and is not used to refer to a bicycle or ergometer.

3.2.6 *direct drive exercise bicycle, n*—stationary exercise bicycle wherein the flywheel is directly coupled to the pedals without the use of a freewheel mechanism, also referred to as fixed wheel exercise bicycle. These exercise bicycles are often used in a “class” or group institutional setting.

3.2.7 *ergometer, n*—stationary exercise bicycle-like device where the user is in a seated or standing position and engages the crank mechanism by hand as shown in Fig. 1 or the equipment may have both upper body and lower body cranks

as shown in Fig. 2. The unit may have a back support; similar to a recumbent bicycle that supports the user’s back.

3.2.7.1 *Discussion*—Upper body ergometer is used to specify an ergometer with only upper body components for motions. Total body ergometer is used to specify an ergometer with both upper and lower body components for motion.

3.2.8 *flywheel, n*—a heavy wheel for opposing and moderating, by its inertia, fluctuations of speed in the exercise bicycle on which it is mounted.

3.2.9 *freewheel, n*—a mechanism that is designed to disengage the flywheel from the pedal mechanism in one direction.

3.2.10 *handlebar, n*—the means that are provided to a user to enhance balance and stability by partially or substantially supporting the user’s weight with the user’s arms.

3.2.11 *handlebar stem, n*—connection between the handlebar and frame, often provided to adjust the height of the handlebar.

3.2.12 *institutional exercise bicycle, n*—stationary exercise bicycle intended for use by numerous persons in a commercial or institutional environment, as opposed to a consumer or residential environment.

3.2.13 *pedal, n*—a device designed to support the foot while the user is performing the exercise as intended by the manufacturer, or while the user mounts or dismounts the equipment.

3.2.14 *recumbent exercise bicycle, n*—stationary exercise bicycle where the lower body exercise is performed with the user in a seated position with their back against a back support and with the crank more in front of the body than underneath it, for example, Fig. 3 versus Fig. 4.

3.2.15 *seat, n*—component on which the user sits thereby providing support for the user’s weight when in a sitting posture.

3.2.16 *seat post, n*—connection between the seat and frame, often used to adjust the height of the seat.

3.2.17 *seat sleeve tube, n*—the part of the frame where the seat post is inserted.

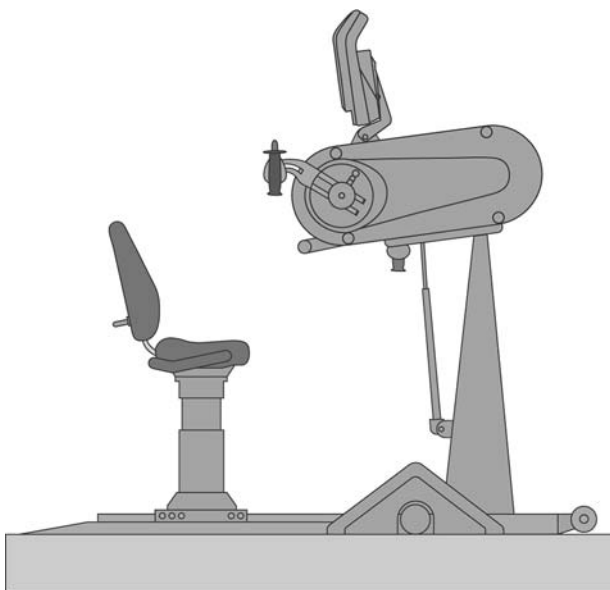

FIG. 1 Upper Body Ergometer

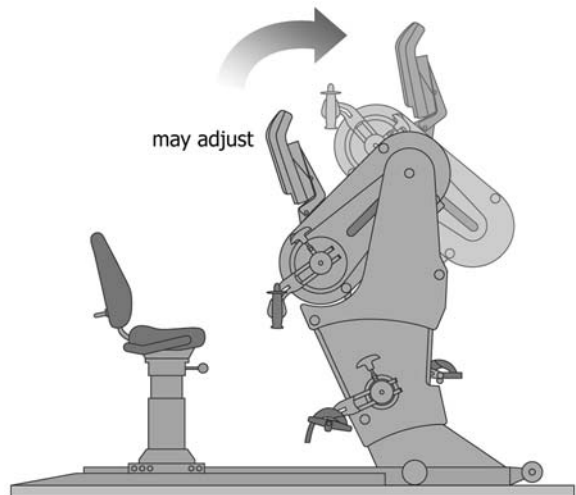

FIG. 2 Total Body Ergometer

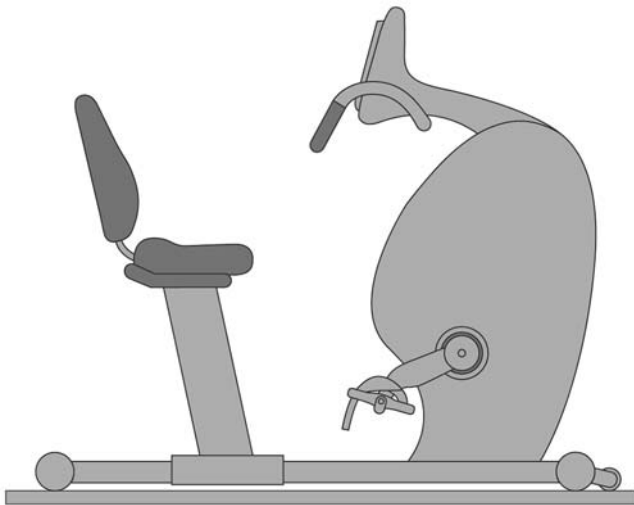

FIG. 3 Recumbent Exercise Bicycle



FIG. 5 Direct Drive Exercise Bicycle

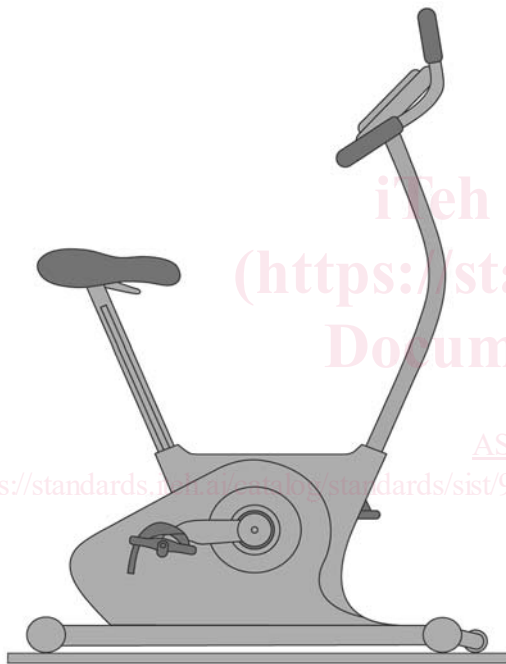

FIG. 4 Upright Exercise Bicycle

3.2.18 *seat support, n*—the part of the seat post where the seat pad is secured or mounted.

3.2.19 *stationary exercise bicycle, n*—stationary training equipment that positions a user’s upper or lower body in an upright or recumbent position to turn a directly coupled or connected flywheel or freewheel crank mechanism with the user’s feet.

3.2.20 *upright exercise bicycle, n*—stationary exercise bicycle with a crank coupled to a freewheel mechanism, where the lower body exercise is performed with the user in a seated position and with the crank more underneath the body, for example, Fig. 4 versus Fig. 3.

#### 4. Equipment Types

4.1 See Figs. 1-5 for equipment types.

#### 5. Design and Construction Requirements

NOTE 1—In addition to the design and construction requirements set forth in Specification F2276, the following requirements are applicable.

##### 5.1 Seat Post:

5.1.1 *Insertion Depth*—The seat post for exercise bicycles shall have a permanent line indicating the minimum insertion depth of at least 1.5 times the largest cross section dimension (for example, diameter or longest dimension of the inserted seat post) into the seat sleeve tube. A mark is not required if the minimum insertion depth is provided by the design, that is, the seat post cannot be removed without the use of tools or the design prevents placement in a position that will not support the load requirement. Example: a seat post having a slot and an outer sleeve tube with a pin or bolt that engages with the slot, ensuring the minimum insertion depth of the seat post and preventing removal of the seat post from the seat sleeve tube.

5.1.2 The seat shall be adjustable as specified by the manufacturer. The seat post shall be retained by a clamp, pin, or similar means.

5.1.3 The seat shall be mounted onto the seat post with a seat support plate or other means to protect against impalement.

5.1.4 The seat and seat post shall meet the intrinsic loading requirements of Specification F2276 where the loading factor to be applied is 2.5 for both consumer and institutional equipment.

5.2 *Seat Deflection or Tilt*—When properly adjusted for use according to the manufacturer’s specifications, and tested in accordance with the test method, the seat shall not pivot in an upward, downward about or through its connection means through an angle greater than  $2 \pm \frac{1}{2}^\circ$  when a load of 0.66 times the maximum user body weight or 89.1 kg (196.4 lb), whichever is greater, is applied.

5.3 *Seat Back Support*—The seat back support shall withstand a load applied to it in accordance with the test method

and per the specifications defined below, without breakage as defined in Subsection 6.3 of Test Methods **F3023**. For consumer exercise bicycles this load shall be 1.0 times the maximum user weight (as defined by the manufacturer) or 135 kg (297.6 lb) whichever is greater. For institutional exercise bicycles, this load shall be 1.5 times the maximum user weight (as defined by the manufacturer) or 202.5 kg (446.4 lb) whichever is greater.

**5.4 Handlebar Stem Insertion – Insertion Depth**—If a vertical stem adjustment is used, the handlebar stem or equivalent shall have a permanent line indicating the minimum insertion depth of at least 1.5 times the largest cross section dimension (for example, diameter or longest dimension of the inserted handlebar stem). A mark is not required if the minimum insertion depth is provided by the design (for example, the handlebar stem or equivalent cannot be removed without the use of tools) or if the design prevents placement of the handlebar stem or equivalent in a position that will not support the load requirement. Example: a handlebar stem having a slot and an outer sleeve tube with a pin or bolt that engages with the slot, ensuring the minimum insertion depth of the handlebar stem and preventing removal of the handlebar stem from the outer sleeve tube.

**5.4.1** The handlebar shall be adjustable as prescribed by the manufacturer’s specifications. The handlebar shall be retained by a clamp, pin, or similar means.

**5.5 Static Loading of Handlebars:**

**5.5.1 Horizontal Axis Torque Evaluation**—If a clamping retention system is used to retain the handlebars then the handlebars shall not rotate about its longitudinal or lateral horizontal axes when a moment of 61 N·m (45 ft·lb) is applied.

**5.5.2 Vertical Axis Torque Evaluation**—If a clamping retention system is used to retain the handlebars then the handlebar shall not rotate around its vertical axis when a moment of 47 N·m (35 ft·lb) is applied.

**5.5.3 Consumer bicycle handlebars for bicycles with a freewheel**—Handlebars shall withstand a loading of 0.3 times the maximum user body weight or 34.2 kg (75.4 lb), whichever is greater, without breakage.

**5.5.4 Consumer bicycle handlebars on direct drive exercise bicycles**—Handlebars shall withstand a loading of 1.5 times the maximum user body weight or 151.7 kg (334.4 lb), whichever is greater, without breakage.

**5.5.5 Institutional bicycle handlebars for bicycles with a freewheel**—Handlebars shall withstand a loading of 0.3 times the maximum user body weight or 60.7 kg (133.8 lb), whichever is greater, without breakage.

**5.5.6 Institutional bicycle handlebars on direct drive exercise bicycles**—Handlebars shall withstand a loading of 1.5 times the maximum user body weight or 202.5 kg (446.4 lb), whichever is greater, without breakage.

**5.5.7 Recumbent Seat Support Handlebars**—For both consumer and institutional recumbent exercise bicycles, handlebars shall withstand a vertical load of 2.5 times the maximum user weight specified by the manufacturer or 337.5 kg (744.1 lb), whichever is greater, without breakage. This load is to be distributed across both handlebars or ½ the load may be applied to one seat support handlebar.

**5.6 Pedals:**

**5.6.1** Pedals shall have right hand/left hand symmetry.

**5.6.2** The surface of the pedal contacted by the user during use shall be slip-resistant.

**5.6.3** A minimum clearance of 60 mm (2.4 in.) shall be provided below the pedals when they are in a horizontal position at the lowest level.

NOTE 2—Flexible components (such as foot straps or flexible toe cages) are allowed to hang below the pedals as long as the non-flexible components maintain the 60 mm (2.4 in.) minimum clearance.

**5.6.4** Pedals shall meet the static loading requirements of Specification **F2276** where the loading factor to be used is 2.5 for both consumer and institutional equipment.

**5.7 Pedal and Crank Endurance:**

**5.7.1** Pedals and crank arms on the equipment defined in this specification shall be tested for 1 000 000 vertical loading cycles (institutional) or 500 000 vertical loading cycles (consumer). These loading cycles do not involve crank arm rotation. The test load for each equipment type is provided below. There shall be no breakage throughout the cycle testing and the pedal and crank arm assembly shall function as intended upon completion of the testing.

**5.7.1.1 Direct Drive Exercise Bicycle Pedal Test Loads**—Institutional direct drive exercise bicycle pedals shall endure a load of weight 135 kg (297.6 lb) or 1.0 times the maximum user weight specified by the manufacturer, whichever is greater. Consumer direct drive exercise bicycle pedals shall endure a load of weight 114 kg (251.3 lb) or 1.0 times the maximum user weight specified by the manufacturer, whichever is greater.

**5.7.1.2 Upright Exercise Bicycle Pedal Test Loads**—Institutional upright bicycle pedals shall endure a load of 101.3 kg (223.3 lb) or 0.75 times the maximum user weight specified by the manufacturer, whichever is greater. Consumer upright bicycle pedals shall endure a load of 85.5 kg (188.5 lb) or 0.75 times the maximum user weight specified by the manufacturer, whichever is greater.

**5.7.1.3 Recumbent Exercise Bicycle Pedal Test Loads**—Institutional recumbent bicycle pedals shall endure a load of 67.5 kg (148.8 lb) or 0.5 times the maximum user weight specified by the manufacturer, whichever is greater. Consumer recumbent bicycle pedals shall endure a load of 57 kg (125.7 lb) or 0.5 times the maximum user weight specified by the manufacturer, whichever is greater.

**5.7.1.4 Total Body Ergometer Pedal Test Loads**—Total body ergometer pedals shall endure a load at the pedal of 67.5 kg (148.8 lb) or 0.5 times the maximum user weight specified by the manufacturer, whichever is greater.

**5.8 Crank Arm and Shroud Entrapment**—The movement of the crank arm relative to the shroud enclosure or other fixture of the exercise bicycle/ergometer shall not create an entrapment hazard.

**5.9 Drive Train**—Drive train elements shall meet the Guarding and Entrapment of Specification **F2276**.

**5.10 Institutional Bicycle/Ergometer Endurance Testing:**

5.10.1 *Test Cycles and Speed*—Institutional bicycles shall be tested for 1 000 000 complete cycles (360° of rotation) and maintaining a minimum angular speed of 40 rpm.

5.10.2 *Direct Drive Exercise Bicycle Test Loads*—Institutional direct drive exercise bicycles shall endure a peak load of 101.3 kg (223.3 lb) or 0.75 times the maximum user weight specified by the manufacturer, whichever is greater.

5.10.3 *Upright Bicycle Test Loads*—Institutional upright bicycles shall endure a peak load of 67.5 kg (148.8 lb) or 0.5 times the maximum user weight specified by the manufacturer, whichever is greater.

5.10.4 *Recumbent Bicycle Test Loads*—Institutional recumbent bicycles shall endure a peak load of 40.5 kg (89.3 lb) or 0.3 times the maximum user weight specified by the manufacturer, whichever is greater.

5.10.5 *Upper Body Ergometer Test Loads*—Institutional upper body ergometers shall endure a peak load at the crank handle of 40.5 kg (89.3 lb) or 0.3 times the maximum user weight specified by the manufacturer, whichever is greater.

5.10.6 *Total Body Ergometer Test Loads*—Institutional total body ergometers shall be tested separately at the upper body interface and the lower body interface. Total body ergometers shall endure a peak load at the crank handle of 40.5 kg (89.3 lb) or 0.3 times the maximum user weight specified by the manufacturer, whichever is greater, and a peak load at the pedal of 67.5 kg (148.8 lb) or 0.5 times the maximum user weight specified by the manufacturer, whichever is greater.

#### 5.11 *Consumer Bicycle/Ergometer Endurance Testing:*

5.11.1 *Test Cycles and Speed*—Consumer bicycles shall be tested for 375 000 complete cycles (360° of rotation) and maintaining a minimum angular speed of 40 rpm.

5.11.2 *Direct Drive Exercise Bicycle Test Loads*—Consumer direct drive exercise bicycles shall endure a peak load of 85.5 kg (188.5 lb) or 0.75 times the maximum user weight specified by the manufacturer, whichever is greater.

5.11.3 *Upright Bicycle Test Loads*—Consumer upright bicycles shall endure a peak load of 57 kg (125.7 lb) or 0.5 times the maximum user weight specified by the manufacturer, whichever is greater.

5.11.4 *Recumbent Bicycle Test Loads*—Consumer recumbent bicycles shall endure a peak load of 28.5 kg (62.8 lb) or 0.25 times the maximum user weight specified by the manufacturer, whichever is greater.

5.11.5 *Upper Body Ergometer Test Loads*—Consumer upper body ergometers shall endure a peak load at the crank handle of 34.2 kg (75.4 lb) or 0.3 times the maximum user weight specified by the manufacturer, whichever is greater.

5.11.6 *Total Body Ergometer Test Loads*—Consumer total body ergometers shall be tested separately at the upper body interface and the lower body interface. Total body ergometers shall endure a peak load at the crank handle of 22.8 kg (50.3 lb) or 0.2 times the maximum user weight specified by the manufacturer, whichever is greater, and a peak load at the pedal of 28.5 kg (62.8 lb) or 0.25 times the maximum user weight specified by the manufacturer, whichever is greater.

5.12 *Stability*—The equipment shall comply with stability requirements of Specification **F2276** and be tested in accordance with Test Methods **F3023**.

## 6. Additional Universal Design and Construction Requirements to Specification **F3021**

6.1 This set of accessibility criteria shall be used in conjunction with the specifications above and Specification **F3021**. This set of criteria pertains only to commercial equipment designed to be accessible to people with disabilities in addition to those without disability.

NOTE 3—If a conflict exists with the requirements listed in Specification **F3021**, then the specific requirements listed here take precedence over the requirements listed in Specification **F3021**.

### 6.2 *Stationary Exercise Bicycles:*

#### 6.2.1 *Access and Setup:*

6.2.1.1 *Upright Bicycle Step-Over Height*—The upright exercise bicycle maximum step-over height shall be no higher than 550 mm (21.7 in.) measured from the ground to the highest point of the framework for a minimum clearance width of 300 mm (11.8 in.) in the primary step-over direction.

6.2.1.2 *Upright Bicycle Step Assist*—Inclusive design upright exercise bicycles shall have a step assist that is located between the control console support structure and the seat post. The step able (usable) surface of the step assist shall be a non-slip surface material with a minimum width of 75 mm (3.0 in.) and minimum length of 150 mm (5.9 in.), and shall meet the loading requirements of Specification **F2276**.

NOTE 4—Some people use this support structure as a step-up mechanism to mount the upright exercise bicycle, see the structure located between the control console support and the seat post in **Fig. 4**.

6.2.1.3 *Recumbent Bicycle Walk Through Transition Area Box*—Recumbent exercise bicycles shall have a minimum leg/foot transition area to allow walk through. With the seat adjusted in mid-position, there shall be a minimum transition area box with a minimum horizontal distance of 205 mm (8.1 in.) between the seat/seat frame and the crank frame, and a minimum vertical distance of 635 mm (25 in.) between the top surface of the bottom step-over structure and the front handlebars or any other fixed obstacle overhanging the step-over structure. The foot transition rectangular area immediately above the step-over structure shall be in the direction of the front of the bicycle to allow free passing of the user's foot. The foot transition rectangle shall have the following minimum dimensions: 305 mm (12.0 in.) horizontally and 150 mm (5.9 in.) vertically. The back edge of the foot transition rectangular area shall be coincident with the back edge of the leg transition rectangular area. (See **Fig. 6**).

NOTE 5—Anything adjustable or removable can be adjusted into the most favorable condition, that is, foot pedals and seat.

#### 6.2.2 *Seats, Saddles, and Back Supports:*

6.2.2.1 *Upright Bicycle Saddle Height*—When adjusted in its lowest position, the upright exercise bicycle saddle height shall be a maximum of 740 mm (29.1 in.) when measured from the ground to the top of the seat/saddle (see **Fig. 7**).

6.2.2.2 *Upright Bicycle Seat Surface Width and Depth*—Saddles on upright exercise bicycles shall have minimum dimensions of 250 mm (9.8 in.) width at the widest point in the hip/pelvic area where the user is being supported and 250 mm (9.8 in.) depth at the centerline of the seat (see **Fig. 8**).

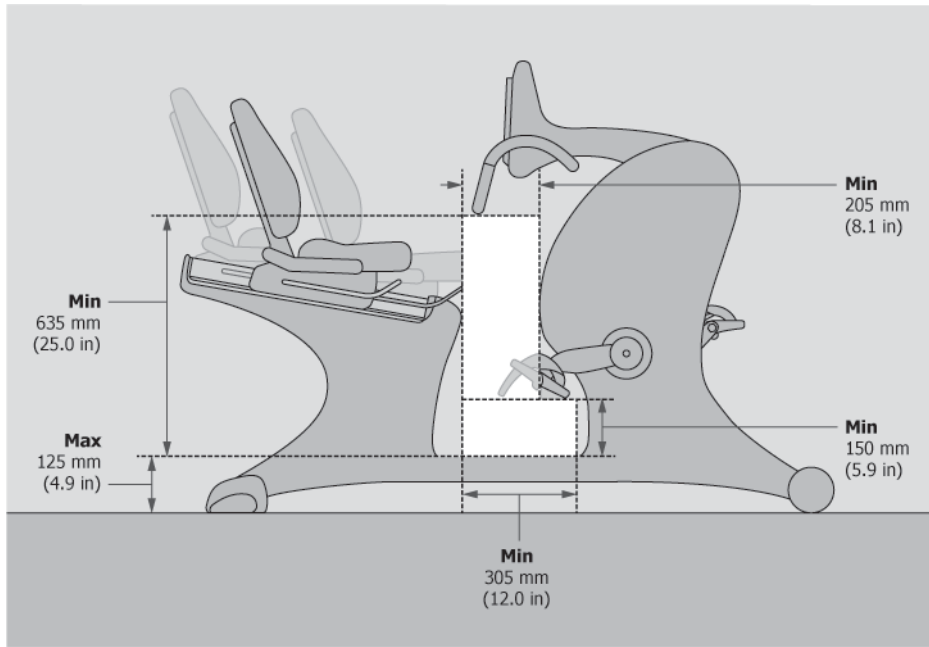

FIG. 6 Dimensions for Transition Area Box

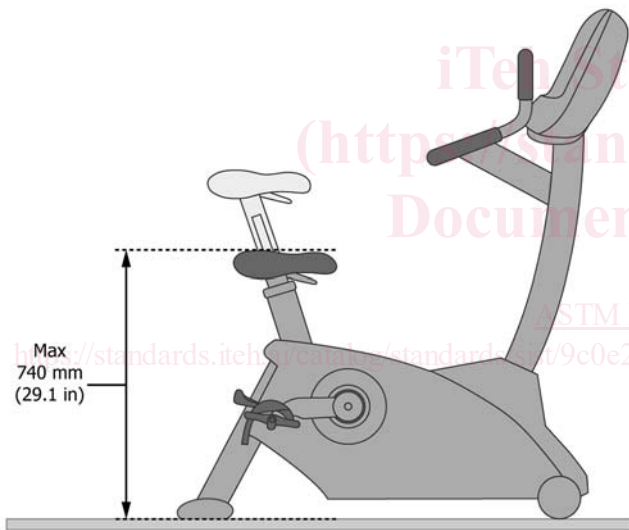

FIG. 7 Upright Exercise Bicycle Seat Height

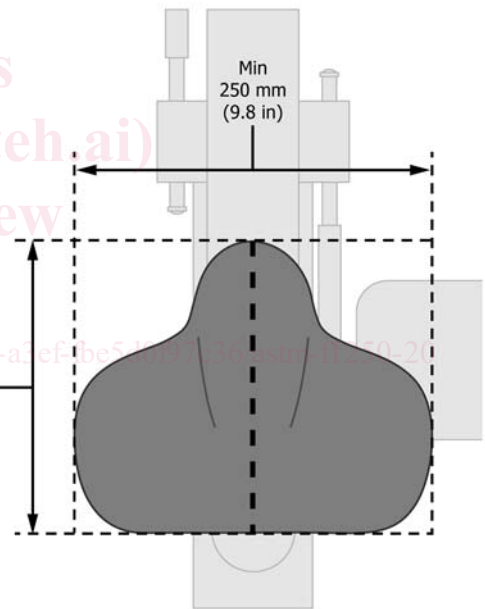

FIG. 8 Upright Exercise Bicycle Seat Width and Depth

NOTE 6—Upright exercise bicycles are exempt from the Specification F3021 removable seat requirement.

NOTE 7—Upright exercise bicycles are exempt from the Specification F3021 minimum 5° seat angle requirement.

6.2.3 *Handlebar – Front Handlebar Length*—Upright exercise bicycles shall have a front, lateral static handlebar for a minimum gripping area length of 300 mm (11.8 in.) (see Fig. 9).

NOTE 8—The gripping area can be divided in half on the left and right sides, that is, 150 mm (5.9 in.) and 150 mm (5.9 in.) on the sides of a center hub/console.

6.2.4 *Foot Pedals:*

6.2.4.1 *Self-Righting Pedals*—Each pedal shall self-right to between 0° and 45° to the horizontal and such that the usable foot surface is presented to the user (see Fig. 10).

6.2.4.2 *Adjustable Heel Retentions*—Pedals shall have adjustable heel retention through a range of shoe sizes to retain the foot in a stable position and prevent the foot from slipping off the pedals when exercising. Heel straps may be permanently fixed or detachable.

NOTE 9—Consideration should be given to user foot sizes from 5 % female to 95 % male.

NOTE 10—Heel retention, for example, strap or support, is a mechanism intended to maintain the heel of the foot in the correct position on the foot pedal during exercise.

(1) Detachable heel retentions shall comply with Specification F3021, Subsection 5.1.3.7 for tethered adjustment mechanisms.

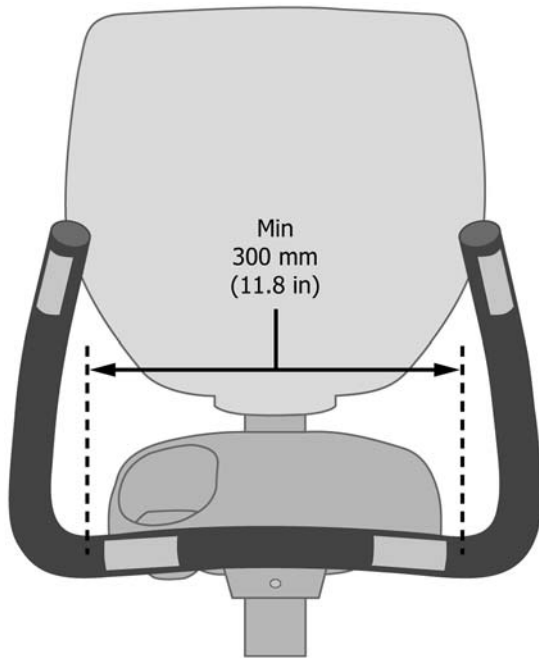

FIG. 9 Handlebar Length

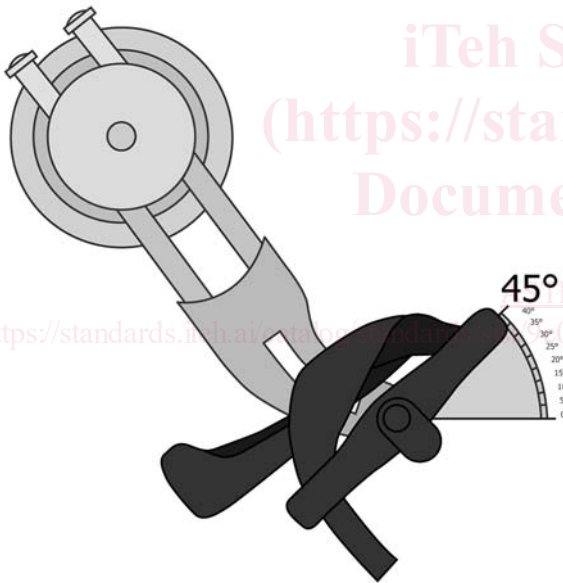

FIG. 10 Foot Pedals

6.3 Ergometers—Ergometers must comply with Specification F3021 requirements for removable seats.

NOTE 11—Ergometers are exempt from the Specification F3021 7.5 kg (16.5 lb) removable/movable seat weight and the Specification F3021 one-handed adjustment requirements.

6.3.1 Hand Cranks:

6.3.1.1 Adjustable Crank Axle Height—Crank axles shall have adjustable heights for the point of rotation from a lower height less than or equal to 800 mm (31.5 in.) to an upper height that is greater than or equal to 1335 mm (52.6 in.) as measured from the axle/spindle to the ground (see Fig. 11).

6.3.1.2 Adjustable Hand Crank Length—Hand crank arm lengths shall be independently adjustable in length from a shorter crank arm length of no greater than 150 mm (5.9 in.) to a longer crank arm length of no less than 230 mm (9.1 in.) from the axle/spindle to the outer edge of the crank handle (see Fig. 12).

6.3.1.3 Hand Crank Adjustments—Hand crank adjustments shall be achievable by the user without the need for additional tools or equipment (see Fig. 13).

6.3.1.4 Crank Handle Retaining Assist—Crank handles shall have a retaining assist feature to block the hand from slipping off the end of the hand grip, for example, a strap, lip, or curvature.

6.3.2 Foot Pedals/Cranks:

6.3.2.1 Foot Pedals—Ergometers that have foot pedals shall comply with 6.2.4.

6.3.2.2 Adjustable Foot Crank—For ergometers that have foot pedals, the foot crank arm lengths shall be independently adjustable in length from a shorter foot crank arm length of no greater than 110 mm (4.3 in.) to a longer foot crank arm length of no less than 175 mm (6.9 in.) from the axle/spindle to the outer edge of the foot pedal (see Fig. 14).

7. Documentation

7.1 Documentation provided with stationary exercise bicycles and ergometers shall meet the guidelines established in Specification F2276 and shall also include the following:

7.1.1 Owner's/User's Manual—A user's manual shall be made available. Safety information and warnings shall be provided with the product.

7.1.2 Assembly Instructions—If the stationary exercise bicycle or ergometer requires assembly, a manual detailing the assembly procedure shall be made available.

7.1.2.1 Information relating to the proper adjustment of the seat and handlebars including their minimum insertion depth of the adjustment posts shall be provided.

7.1.2.2 Information relating to the procedure for leveling stationary exercise bicycles or ergometers shall be provided.

7.1.3 Operational Instructions—In addition to the requirements of Specification F2276 the following topics shall be included:

7.1.3.1 The function of any immobilization methods.

7.1.3.2 Function of any emergency stop methods.

7.1.3.3 Operation of all controls on the control panel.

7.1.3.4 Instructions for safe mounting and dismounting of the equipment.

7.1.4 Maintenance Instructions—Care and necessary maintenance advice shall be provided. This shall include a review of all applicable warning notices and how replacement warning labels can be obtained. Special attention shall be drawn to components most susceptible to wear.

7.1.4.1 Only manufacturer-supplied components shall be used to maintain/repair the equipment.

7.1.5 Installation Instructions—Installation instructions for stationary exercise bicycles or ergometers shall be provided and shall include as a minimum the following: