



Designation: D1790 – 21

# Standard Test Method for Brittleness Temperature of Plastic Sheeting by Impact<sup>1</sup>

This standard is issued under the fixed designation D1790; the number immediately following the designation indicates the year of original adoption or, in the case of revision, the year of last revision. A number in parentheses indicates the year of last reapproval. A superscript epsilon ( $\epsilon$ ) indicates an editorial change since the last revision or reapproval.

*This standard has been approved for use by agencies of the U.S. Department of Defense.*

## 1. Scope\*

1.1 This test method covers the determination of that temperature at which plastic sheeting 1.00 mm (0.040 in.) or less in thickness exhibits a brittle failure under specified impact conditions.

1.2 The values stated in SI units are to be regarded as the standard. The values given in parentheses are for information only.

NOTE 1—This test method was developed jointly with the Society of the Plastics Industry, primarily for use with plasticized vinyl sheetings. Its applicability to other plastic sheetings must be verified by the user.

1.3 *This standard does not purport to address all of the safety concerns, if any, associated with its use. It is the responsibility of the user of this standard to establish appropriate safety, health, and environmental practices and determine the applicability of regulatory limitations prior to use.*

NOTE 2—This test method and ISO 8570 address the same subject matter, but differ in technical content.

1.4 *This international standard was developed in accordance with internationally recognized principles on standardization established in the Decision on Principles for the Development of International Standards, Guides and Recommendations issued by the World Trade Organization Technical Barriers to Trade (TBT) Committee.*

## 2. Referenced Documents

2.1 *ASTM Standards:*<sup>2</sup>

- D618 Practice for Conditioning Plastics for Testing
- D883 Terminology Relating to Plastics
- D5947 Test Methods for Physical Dimensions of Solid Plastics Specimens
- D6988 Guide for Determination of Thickness of Plastic Film Test Specimens

<sup>1</sup> This test method is under the jurisdiction of ASTM Committee D20 on Plastics and is the direct responsibility of Subcommittee D20.30 on Thermal Properties.

Current edition approved Jan. 15, 2021. Published February 2021. Originally approved in 1960. Last previous edition approved in 2014 as D1790 - 14. DOI: 10.1520/D1790-21.

<sup>2</sup> For referenced ASTM standards, visit the ASTM website, www.astm.org, or contact ASTM Customer Service at service@astm.org. For *Annual Book of ASTM Standards* volume information, refer to the standard's Document Summary page on the ASTM website.

- E456 Terminology Relating to Quality and Statistics
- E691 Practice for Conducting an Interlaboratory Study to Determine the Precision of a Test Method
- E2935 Practice for Conducting Equivalence Tests for Comparing Testing Processes

2.2 *ISO Standard:*

- ISO 8570 Plastics—Film and Sheeting—Determination of Cold-Crack Temperature<sup>3</sup>

## 3. Terminology

3.1 *Definitions:*

3.1.1 *brittleness temperature,  $T_b$* —that temperature, derived statistically, where 80 % of the specimens would probably pass 95 % of the time when a stated minimum number are tested by this test method. The 80 %-passing value is determined by plotting the data on probability graph paper, as described in 9.1.

3.1.2 *General*—Terms used in this standard are defined in accordance with Terminology D883, unless otherwise specified. For terms relating to precision and bias and associated issues, the terms used in this standard are defined in accordance with Terminology E456.

## 4. Significance and Use

4.1 Data obtained by this test method have been used to predict the behavior of plastic sheeting at low temperatures only if the conditions of deformation are similar to those specified in this test method. This test method is useful for specification testing and for comparative purposes, but does not necessarily determine the lowest use temperature for a particular plastic.

4.2 It has been demonstrated that on calendared sheeting the brittleness temperature is sensitive to the direction of fold. It has also been demonstrated that the brittleness temperature is sensitive to the direction of sampling. Therefore, it is imperative that the procedure for taking specimens and folding be followed explicitly.

<sup>3</sup> Available from American National Standards Institute (ANSI), 25 W. 43rd St., 4th Floor, New York, NY 10036, http://www.ansi.org.

\*A Summary of Changes section appears at the end of this standard

**5. Apparatus**

5.1 *Cold Conditioning Chamber*, at least 450 by 450 by 450 mm (18 by 18 by 18 in.). Means (automatic or manual) shall be provided for controlling the temperature of the chamber to within  $\pm 2^{\circ}\text{C}$  of the desired value.

5.2 *Impact Tester* shown in Fig. 1 shall be constructed of cold-rolled steel except for the bolts, screws, and rubber stopper. It is recommended that all structural parts (that is, base, anvil, arm, arm supports, and shaft) be chromium plated to prevent corrosion. The arm, including the rubber stopper and bolt, shall weigh  $3.09\text{ kg} \pm 28\text{ g}$  ( $6\text{ lb } 13 \pm 1\text{ oz}$ ).

5.3 *Die*,  $50.8 \pm 0.4\text{ mm}$  by  $146.1 \pm 0.4\text{ mm}$  ( $2 \pm \frac{1}{64}\text{ in.}$  by  $5\frac{3}{4} \pm \frac{1}{64}\text{ in.}$ ) to cut the test specimens from the sample.

5.4 *Stapler*, desk-type, with a stop mounted on the base exactly  $12.7\text{ mm}$  ( $\frac{1}{2}\text{ in.}$ ) back of the center of the groover that turns the staple.

5.5 *Index Card Stock*, 50 by 127 mm (2 by 5 in.).

5.6 *Thickness Gauge*—A dead-weight dial or digital micrometer as described in D5947 or D6988 as appropriate for the material or specimen geometry being tested.

**6. Test Specimens**

6.1 The test specimens shall be cut with the die. The length of the test specimen shall be parallel to the transverse direction of the sheeting.

6.2 The test specimens shall be selected so that the thickness is uniform to within 10% of the thickness over the length of the specimen in the case of specimens 0.25 mm (0.010 in.) or less

in thickness and to within 5 % in the case of specimens greater than 0.25 mm (0.010 in.) in thickness but do not exceed 1.00 mm (0.040 in.) in thickness.

6.3 The 50-mm (2-in.) ends of each specimen shall be so collected that a gradual, closed loop is formed at room temperatures. The collected ends of the specimen and one end of the 50 by 127-mm (2 by 5-in.) card shall be matched exactly with the body of the loop lying on the card. Two staples shall be crimped through the matched ends of the specimen and card. These staples shall be 13-mm ( $\frac{1}{2}\text{ in.}$ ) from, and parallel to, the 50-mm (2-in.) end of the stack.

6.4 Since it has been demonstrated that this test is sensitive to the direction of fold on calendered sheeting, it is necessary to stipulate that all specimens be folded in the same direction. It is recommended that, for materials with no grain, the specimen be folded so that the surface last in contact with the roll shall be inside the loop following the inherent shape of the specimen; grained materials are to be tested with the grained surface on the inside of the loop.

**7. Conditioning**

7.1 *Conditioning*—Condition the test specimens at  $23 \pm 2^{\circ}\text{C}$  ( $73.4 \pm 3.6^{\circ}\text{F}$ ) and  $50 \pm 10\%$  relative humidity for not less than 40 h prior to test in accordance with Procedure A of Practice D618, for those tests where conditioning is required. In cases of disagreement, the tolerances shall be  $\pm 1^{\circ}\text{C}$  ( $\pm 1.8^{\circ}\text{F}$ ) and  $\pm 5\%$  relative humidity.

7.2 *Test Conditions*—Conduct tests in the standard laboratory environment of  $23 \pm 2^{\circ}\text{C}$  ( $73.4 \pm 3.6^{\circ}\text{F}$ ) and  $50 \pm 10\%$

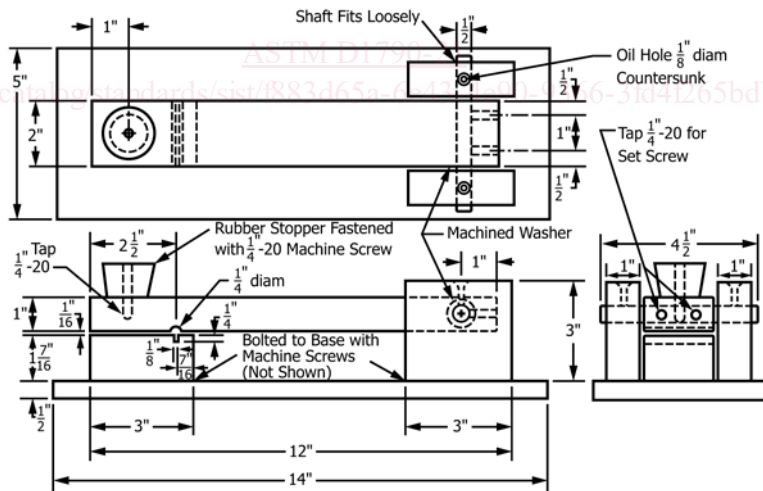

		Metric Equivalents									
in.	1/8	1/4	7/16	1/2	1	2 1/2	3	4 1/2	12	14	
mm	3.2	6.4	11.1	12.7	25.4	64	76	114	305	356	

FIG. 1 Brittleness Temperature Impact Testing Machine

relative humidity, unless otherwise specified in the test methods or in this test method. In cases of disagreements, the tolerances shall be  $\pm 1^{\circ}\text{C}$  ( $\pm 1.8^{\circ}\text{F}$ ) and  $\pm 5\%$  relative humidity.

### 8. Procedure

8.1 Measure the thickness of the specimen at several points along its length to an accuracy of 0.0025 mm (0.0001 in.) or better for specimens 0.25 mm (0.010 in.) or less in thickness and to an accuracy of 1 % or better for specimens greater than 0.25 mm (0.010 in.) in thickness but do not exceed 1.00 mm (0.040 in.) in thickness.

NOTE 3—Refer to D6988 for specimens 0.25 mm (0.010 in.) or less in thickness.

NOTE 4—Refer to D5947 for specimens greater than 0.25 mm (0.010 in.) in thickness.

8.2 Place the impact tester, with its base horizontal, in the cold conditioning chamber at the desired testing temperature, for a conditioning period of 1 h. Expose the specimens to the test temperature for  $15 \pm 5$  min.

8.3 Place each of ten mounted test specimens individually on the anvil with the crimped ends of the staples on the back of the card fitted into the groove in the anvil. Handle the card, not the sample. Locate the bent loop of the sheeting on the anvil with the loop centered on the anvil and facing away from the pivotal end of the impact arm.

8.4 Allow the impact arm to fall free from a position within  $5^{\circ}$  perpendicular to the base onto the bent loop. Repeat until each of the ten conditioned specimens has been tested.

8.5 Remove the specimens and examine for failure. Partial fracture shall be construed as failure as well as complete division into two or more pieces.

8.6 Adjust the temperature of the cold conditioning chamber in order to have a minimum of four results, two above and two below the 50 % point. Condition the groups of ten specimens for  $15 \pm 5$  min at the selected temperatures, as indicated by the results of testing. Repeat the testing procedure and examination.

8.7 When testing for conformance to a specification, it shall be satisfactory to accept materials on the basis of testing a minimum of ten test specimens at the specified temperature. Not more than 20 % of the specified number of test specimens shall fail at the specified temperature.

### 9. Calculation

9.1 Plot the data on probability graph paper with the temperature on the linear scale and the percentage failure on the probability scale. Select the temperature scale so that it represents a minimum of two divisions per degree Celsius. Draw a straight line through a minimum of four points, two above and two below the 50 % point. The temperature indicated at the intersection of the data line with the 20 % failure line shall be reported as  $T_b$ , the 80 % passing temperature (20 % failure temperature).

### 10. Report

10.1 Report the following information:

10.1.1 Complete identification of the material tested, including type, source, manufacturer’s code designation, form, and previous history,

10.1.2 Eighty percent passing temperature, to the nearest degree Celsius,

10.1.3 Thickness of test specimen,

10.1.4 Direction of fold,

10.1.5 Conditioning procedure, and

10.1.6 Date of test.

10.2 For routine acceptance testing, report the following instead of 10.1.1, and 10.1.2:

10.2.1 Number of specimens tested,

10.2.2 Temperature of test, and

10.2.3 Number of failures.

### 11. Precision and Bias<sup>4</sup>

11.1 The precision of this test method is based on an interlaboratory study of D1790 Brittleness Temperature of Plastic Sheeting by Impact conducted in 1991. Seven (7) laboratories tested three (3) different materials. Every “test result” represents an individual determination. Each laboratory was asked to submit four (4) replicate test results, from a single operator, for each material. Practice E691 was followed for the design and analysis of the data. (Warning—The data in Table 1 shall not be rigorously applied to acceptance or rejection of material, as those data are specific to the interlaboratory study and are not necessarily representative of other lots, conditions, materials, or laboratories. Users of this test method shall apply the principles outlined in Practice E691 to generate data specific to their laboratory and materials, or between specific laboratories.)

NOTE 5—Material Number 3 (SP-61737 Lot 30) was tested successfully by only three of the seven participating labs due to equipment limitations.

11.2 Equivalence testing on numerical data from two sources shall be conducted in accordance with Practice E2935.

<sup>4</sup> Supporting data have been filed at ASTM International Headquarters and may be obtained by requesting Research Report RR:D20-1174. Contact ASTM Customer Service at service@astm.org.

TABLE 1 Statistical Assessment of Brittleness Temperature Round-Robin Results

Values Expressed in °C							
Number	Material	Description	Average	$S_r$	$S_R$	$r$	$R$
1	HN-81414	Lot 3 Squirrel Grey 0.013 in. (0.33 mm)	-16.2	0.62	2.36	1.74	6.61
2	HC-41310	Lot 2 Special Tan 0.014 in. (0.36 mm)	-18.3	0.80	2.88	2.24	8.10
3	SP-61737	Lot 30 Blue 0.020 in. (0.51 mm)	-39.2	0.73	3.71	2.04	10.4