



Designation: ~~F1306~~—~~16~~ F1306 – 21

# Standard Test Method for Slow Rate Penetration Resistance of Flexible Barrier Films and Laminates<sup>1</sup>

This standard is issued under the fixed designation F1306; the number immediately following the designation indicates the year of original adoption or, in the case of revision, the year of last revision. A number in parentheses indicates the year of last reappraisal. A superscript epsilon ( $\epsilon$ ) indicates an editorial change since the last revision or reappraisal.

## 1. Scope

1.1 This test method permits flexible barrier films and laminates to be characterized for slow rate penetration resistance to a driven probe. The test is performed at room temperature, by applying a biaxial stress at a single test velocity on the material until perforation occurs. The force, energy, and ~~elongation~~ probe penetration to perforation failure are determined.

1.2 The values stated in SI units are to be regarded as standard. The values given in parentheses ~~are mathematical conversions to inch-pound units that~~ after SI units are provided for information only and are not considered standard.

1.3 *This standard does not purport to address all of the safety concerns, if any, associated with its use. It is the responsibility of the user of this standard to establish appropriate ~~safety~~ safety, health, and health environmental practices and determine the applicability of regulatory limitations prior to use.*

1.4 *This international standard was developed in accordance with internationally recognized principles on standardization established in the Decision on Principles for the Development of International Standards, Guides and Recommendations issued by the World Trade Organization Technical Barriers to Trade (TBT) Committee.*

## 2. Referenced Documents

### 2.1 ASTM Standards:<sup>2</sup>

[D374 Test Methods for Thickness of Solid Electrical Insulation \(Metric\) D0374\\_D0374M](#)

[D618 Practice for Conditioning Plastics for Testing](#)

[D638 Test Method for Tensile Properties of Plastics](#)

[E691 Practice for Conducting an Interlaboratory Study to Determine the Precision of a Test Method](#)

[F2251 Test Method for Thickness Measurement of Flexible Packaging Material](#)

### 2.2 ASQ Standards:<sup>3</sup>

[ASQ/ANSI Z1.9 Sampling Procedures and Tables for Inspection by Variables for Percent Nonconforming](#)

## 3. Terminology

### 3.1 Definitions of Terms Specific to This Standard:

3.1.1 *elongation (stretch)*—the elastic/plastic deformation of flexible sheet material under penetration by a driven probe.

<sup>1</sup> This test method is under the jurisdiction of ASTM Committee F02 on Primary Barrier Packaging and is the direct responsibility of Subcommittee F02.20 on Physical Properties.

Current edition approved March 1, 2016 Jan. 15, 2021. Published April 2016 February 2021. Originally approved in 1990. Last previous edition approved in 2008 2016 as F1306 – 99 F1306 – 16 (2008)<sup>2</sup>. DOI: 10.1520/F1306-16.10.1520/F1306-21.

<sup>2</sup> For referenced ASTM standards, visit the ASTM website, www.astm.org, or contact ASTM Customer Service at service@astm.org. For *Annual Book of ASTM Standards* volume information, refer to the ~~standard's~~ standard's Document Summary page on the ASTM website.

<sup>3</sup> Available from American Society for Quality (ASQ), 600 N. Plankinton Ave., Milwaukee, WI 53203, <http://www.asq.org>.

3.1.2 *penetration resistance*—the ability of a flexible sheet material to withstand elongation and/or puncture by a driven probe.

3.1.3 *perforation*—the development of a measurable flaw through a barrier film undergoing penetration.

3.1.4 *probe penetration to failure*—distance probe travels from film contact to an instantaneous drop in load as observed on Universal Testing Equipment recorder/test equipment output.

3.1.5 *puncture*—the brittle elastic fracture of a flexible sheet material under penetration by a driven probe.

3.1.6 *universal testing apparatus*—machine capable of measuring tensile stress and compressive strength of materials.

**4. Significance and Use**

4.1 Penetration resistance is an important end-use performance of thin flexible materials where a sharp-edged product can destroy the integrity of a barrier wrap. This will permit package entry/exit of gases, odors, and unwanted contaminants, causing potential harm to the product and reducing shelf-life. Material response to penetration will vary with numerous factors, such as film thickness, elastic modulus, rate of penetration, temperature, shape and type of probe. Consequently, material responses from puncture to stretch may be observed and quantified using this method. Although numerous combinations of experimental factors can be devised and used to simulate specific end-use applications, the recommended conditions in this method should be followed for standard comparisons of materials.

**5. Apparatus**

5.1 *Universal Testing Apparatus*, with a recording device.

5.2 *Compression Load Cell(s)*.

5.3 *Penetration Probe*, as per in accordance with Fig. 1.

5.3.1 A 3.2 mm (0.125 in.) diameter hemispherical (biaxial stress) probe is recommended for general application and standard comparison of materials and interlaboratory results.

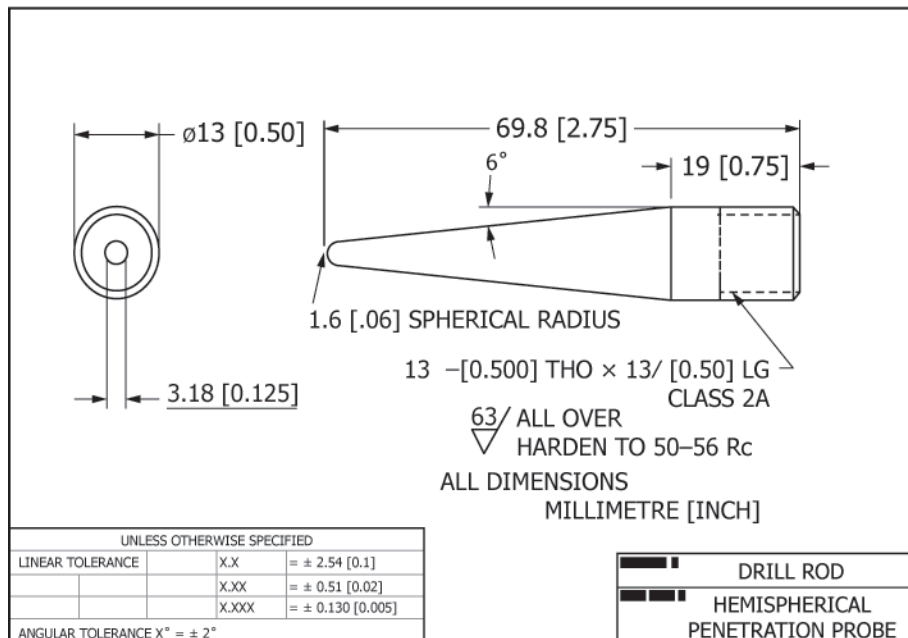

FIG. 1 Penetration Probe

5.4 *Specimen Clamping Fixture*, as per-in accordance with Fig. 2 or equivalent. An apparatus that holds the sample securely, preventing material slip so that testing is not affected. Methods may include a pneumatic clamping mechanism or other mechanical means.

5.4.1 A sample test diameter of 34.935 mm (1.375 in.) is required for interlaboratory comparison of results. (If other probes are used, a minimum clamp to probe diameter ratio of 10 to 1 is required.)

5.5 *Specimen Cutter*.

**6. Test Specimen**

6.1 The test specimen shall be of uniform thickness ( $\pm 2\%$  or 0.0025 mm (0.0001 in.), whichever is larger).

6.2 The dimensions of the test specimen shall be 76 mm by 76 mm (3 in. by 3 in.).

6.3 Where samples are multi-layer and not uniform in structure (ABC versus ABA), each side should be identified and treated as a different material, if penetration direction is important to material use, that is, inside versus outside of package.

**7. Preparation of Apparatus**

7.1 Consult the equipment operations manual for instructions to set up and operate the equipment.

7.2 Install probe apparatus.

7.3 Center probe over the fixture.

**8. Number of Test Specimens**

8.1 Test at least five specimens for each sample. The number of samples tested should be adequate to be predictive of performance

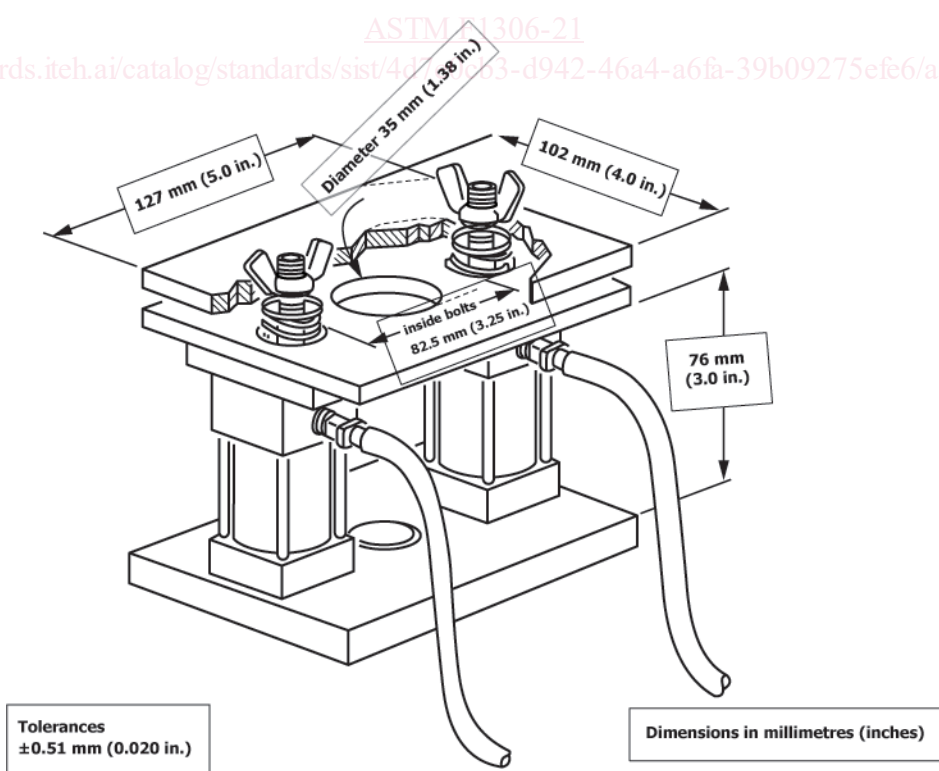

FIG. 2 Specimen Clamping Fixture

and relative to the purpose of the test. Caution should be taken when eliminating samples with defects as this can bias results. See ASQ/ANSI Z1.9 for guidance on sampling plans and practices to establish rationale.

**9. Conditioning**

9.1 Condition the test specimens at  $23 \pm 2^\circ\text{C}$  ( $73.4 \pm 3.6^\circ\text{F}$ ) and  $50 \pm 5\%$  relative humidity for not less than 40 h prior to test in accordance with Procedure A of Practice D618 for those tests where conditioning is required.

9.2 Conduct tests in the standard laboratory atmosphere of  $23 \pm 2^\circ\text{C}$  ( $73.4 \pm 3.6^\circ\text{F}$ ) and  $50 \pm 5\%$  relative humidity unless otherwise specified in this test method.

**10. Procedure**

10.1 ~~Following the instrument manufacturer's instructions, calibrate the test equipment. Test equipment should be calibrated and within the calibration interval~~

10.2 ~~Select an equipment~~ Equipment load range ~~so should be such~~ that specimen puncture occurs within 20 to 80 % of the same.

10.3 Using the specimen cutter, cut each sample material into a ~~minimum of five 3 in. by 3 in. pieces~~; 76 mm (3 in.) by 76 mm (3 in.) piece.

10.4 Measure the caliper (average of 3 readings) in the center of a film specimen. Refer to Test Method F2251.

10.5 Adjust the universal tester cross head speed to 25 mm/min (1.0 in./min). ~~(Set chart speed recorder to 500 mm/min (20 in./min), if applicable.)~~ Select a data acquisition rate to give a minimum resolution of 0.1 mm/point of penetration. ~~(For chart recorders, set chart recording speed to 500 mm/min (20 in./min), if applicable.)~~

10.6 Clamp the film specimen in the holder, place sample holder directly under crosshead probe, center and lower it as close as possible to the film specimen without making contact.

10.7 Set the appropriate stops and returns on the tester. Reset data collection devices to zero, if applicable.

<https://standards.iteh.ai/catalog/standards/sist/4d7e0cb3-d942-46a4-a6fa-39b09275efe6/astm-f1306-21>

10.8 Activate universal tester. At the first sign of a perforation through the film, return the crosshead to origination point. (A perforation is any size hole in the film specimen visible to the naked eye, or a point where an instantaneous drop in load to near zero occurs.) See Fig. 3.

NOTE 1—In case of laminate materials, multiple drops in load may be observed as discrete layers fail. Under this condition, the last instantaneous drop to near zero would be considered a failure.

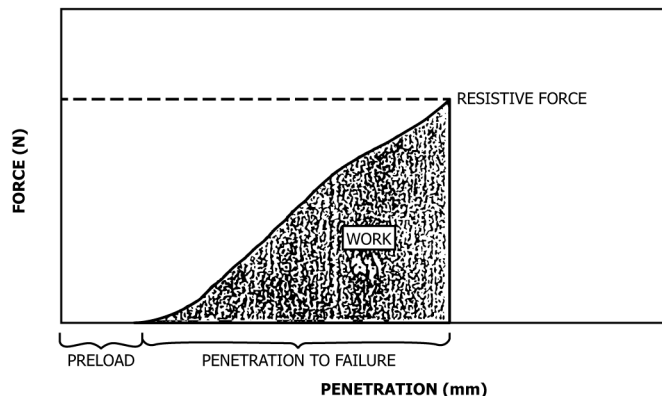

FIG. 3 Graphical Output of Slow Rate Penetration Test

10.9 Record specimen identification, force (peak) to break, energy (work) to break, and probe penetration (at first break) from mechanical testing software output (Fig. 3). (If using chart recording instruments, record specimen identification on chart and integrator reading if used.)

10.10 Repeat test sequence (10.1 to 10.9) for the remaining samples.

## 11. Calculation

11.1 Compute the values of peak force, probe penetration to break, and energy to break.

11.1.1 Software computed values are acceptable.

11.2 Use the following formulas for calculating the required values for data acquisition with a time based chart recorder.

11.2.1 *Force to Break*—Peak force to achieve break (Newtons):-(Newtons). Testers with digital outputs most often hold peak force measurement data for use in characterizing the material sample. In the case of devices with paper recorders, the peak force may need to be calculated based on the full scale of the load cell relative to the movement of the chart during test cycle as shown below:

$$N = R \times L \text{ or } \frac{D}{W} \times L \quad (1)$$

where:

$N$  = force to break (Newtons),

$R$  = chart reading (%), expressed as a decimal,

$L$  = full scale load (FSL),  $N_2$

$\cancel{D}$  = ~~recorded actual millimeters of chart in vertical axis, from start of test to finish, and~~

$\underline{D}$  = recorded actual millimetres of chart in vertical axis, from start of test to finish, and

$W$  = full scale width of chart, mm.

11.2.2 *Probe Penetration*—Depth probe traveled in penetrating film specimen (mm), from initial probe contact with sample, to penetration at ~~break~~-break. The probe distance travelled from where material contact is made and resistance begins to generate measurement up to the peak load end of the test cycle is data collected by digital tensile testers. For chart recorders the crosshead and chart recorder speed may be set at different rates. In this case the length of the chart recording must be normalized to the chart speed as shown below in order to get the correct distance:

$$P = \frac{D \times S}{C} \quad (2)$$

where:

$P$  = probe travel to penetration at first break, mm,

$\cancel{D}$  = ~~recorded actual millimeters of chart in vertical axis, from start of test to finish,~~

$\underline{D}$  = recorded actual millimetres of chart in vertical axis, from start of test to finish,

**TABLE 1 Puncture Force (6 Laboratories)**

Material	Material Orientation	Values expressed in units of Newtons				
		Average	$S_r$	$S_R$	$r$	$R$
BW 010	Inside	6.63	0.187	0.676	0.525	1.891
BW 010	Outside	6.72	0.360	0.903	1.015	2.528
BW 82	Inside	9.47	1.94	2.034	5.429	5.696
BW 82	Outside	9.08	2.23	2.416	6.226	6.773
BW 117	Inside	12.10	1.615	2.238	4.521	6.608
BW 117	Outside	12.37	1.798	2.852	5.029	7.983
BW 295	Inside	42.54	1.776	2.078	4.966	5.816
BW 295	Outside	36.49	0.983	3.066	2.756	8.580
BW 341	Inside	41.83	2.697	3.502	7.547	9.803
BW 341	Outside	42.94	3.400	4.971	9.514	13.920
BW 234	Inside	72.31	11.080	14.285	31.061	39.961
BW 234	Outside	65.64	16.421	17.266	45.969	48.372