



Designation: F820 – 21

# Standard Test Method for Measuring Air Performance Characteristics of Central Vacuum Cleaning Systems<sup>1</sup>

This standard is issued under the fixed designation F820; the number immediately following the designation indicates the year of original adoption or, in the case of revision, the year of last revision. A number in parentheses indicates the year of last reapproval. A superscript epsilon ( $\epsilon$ ) indicates an editorial change since the last revision or reapproval.

## 1. Scope

1.1 This test method covers procedures for determining air performance characteristics of household central vacuum cleaning systems, which use a flexible cleaning hose assembly and incorporates a series universal motor(s). This test method does not apply to the carpet cleaning mode of operation where dirt or debris is involved.

1.2 These tests and calculations include determination of suction, airflow, air power, maximum air power, and input power under standard operating conditions (see **Note 1**).

**NOTE 1**—For more information on air performance characteristics, see Refs **(1-6)**.<sup>2</sup>

1.3 The values stated in inch-pound units are to be regarded as the standard. The values given in parentheses are provided for information only.

1.4 *This standard does not purport to address all of the safety concerns, if any, associated with its use. It is the responsibility of the user of this standard to establish appropriate safety, health, and environmental practices and determine the applicability of regulatory limitations prior to use. A specific precautionary statement is given in **Note 4**.*

1.5 *This international standard was developed in accordance with internationally recognized principles on standardization established in the Decision on Principles for the Development of International Standards, Guides and Recommendations issued by the World Trade Organization Technical Barriers to Trade (TBT) Committee.*

## 2. Referenced Documents

### 2.1 ASTM Standards:<sup>3</sup>

**E1** Specification for ASTM Liquid-in-Glass Thermometers

<sup>1</sup> This test method is under the jurisdiction of ASTM Committee **F11** on Vacuum Cleaners and is the direct responsibility of Subcommittee **F11.22** on Air Performance.

Current edition approved Feb. 1, 2021. Published February 2021. Originally approved in 1988. Last previous edition approved in 2018 as F820 – 18. DOI: 10.1520/F0820-21.

<sup>2</sup> The boldface numbers in parentheses refer to the list of references at the end of this standard.

<sup>3</sup> For referenced ASTM standards, visit the ASTM website, [www.astm.org](http://www.astm.org), or contact ASTM Customer Service at [service@astm.org](mailto:service@astm.org). For *Annual Book of ASTM Standards* volume information, refer to the standard's Document Summary page on the ASTM website.

**E177** Practice for Use of the Terms Precision and Bias in ASTM Test Methods

**E691** Practice for Conducting an Interlaboratory Study to Determine the Precision of a Test Method

**E2251** Specification for Liquid-in-Glass ASTM Thermometers with Low-Hazard Precision Liquids

**F431** Specification for Air Performance Measurement Plenum Chamber for Vacuum Cleaners

2.2 *AMCA Standard*:<sup>4</sup>

**210-85** Laboratory Methods of Testing Fans for Rating

2.3 *IEC Standard*:<sup>5</sup>

**IEC 62885-2** Surface Cleaning Appliances – Part 2: Dry Vacuum Cleaners for Household or Similar Use – Methods for Measuring the Performance

## 3. Terminology

### 3.1 Definitions:

3.1.1 *air power, AP, W, n*—in a vacuum cleaner, the net time rate of work performed by an air stream while expending energy to produce an airflow by a vacuum cleaner under specified air resistance conditions.

3.1.2 *automatic bleed valve, n*—any device a part of a vacuum cleaner's design, which automatically introduces an intentional leak within the vacuum cleaner's system when manufacturer specified conditions are met.

3.1.3 *corrected airflow, Q, cfm, n*—in a vacuum cleaner, the volume of air movement per unit of time under standard atmospheric conditions.

3.1.4 *input power, W, n*—the rate at which electrical energy is absorbed by a vacuum cleaner.

3.1.5 *model, n*—the designation of a group of vacuum cleaners having the same mechanical and electrical construction with only cosmetic or nonfunctional differences.

3.1.6 *population, n*—the total of all units of a particular model vacuum cleaner being tested.

<sup>4</sup> Available from Air Movement and Control Association, Inc., 30 West University Dr., Arlington Heights, IL 60004-1893, <http://www.amca.org>.

<sup>5</sup> Available from the IEC Web store, [webstore.iec.ch](http://webstore.iec.ch), or American National Standards Institute (ANSI), 25 W. 43rd St., 4th Floor, New York, NY 10036, <http://www.ansi.org>.

3.1.7 *repeatability limit (r), n*—the value below which the absolute difference between two individual test results obtained under repeatability conditions may be expected to occur with a probability of approximately 0.95 (95 %).

3.1.8 *reproducibility limit (R), n*—the value below which the absolute difference between two test results obtained under reproducibility conditions may be expected to occur with a probability of approximately 0.95 (95 %).

3.1.9 *repeatability standard deviation (S<sub>r</sub>), n*—the standard deviation of test results obtained under repeatability conditions.

3.1.10 *reproducibility standard deviation (S<sub>R</sub>), n*—the standard deviation of test results obtained under reproducibility conditions.

3.1.11 *sample, n*—a group of vacuum cleaners taken from a large collection of vacuum cleaners of one particular model, which serves to provide information that may be used as a basis for making a decision concerning the larger collection.

3.1.12 *standard air density, ρ<sub>std</sub>, lb/ft<sup>3</sup>, n*—atmospheric air density of 0.075 lb/ft<sup>3</sup> (1.2014 kg/m<sup>3</sup>).

3.1.12.1 *Discussion*—This value of air density corresponds to atmospheric air at a temperature of 68 °F (20 °C), 14.696 psi (101.325 kPa), and approximately 30 % relative humidity.

3.1.13 *suction, inch of water, n*—in a vacuum cleaner, the absolute difference between ambient and subatmospheric pressure.

3.1.14 *test run, n*—the definitive procedure that produces the singular result of calculated maximum air power.

3.1.15 *test station pressure, B<sub>p</sub>, inch of mercury, n*—for a vacuum cleaner, the absolute barometric pressure at the test location (elevation) and test time.

3.1.15.1 *Discussion*—It is not the equivalent mean sea level value of barometric pressure typically reported by the airport and weather bureaus. It is sometimes referred to as the uncorrected barometric pressure (that is, not corrected to the mean sea level equivalent value). Refer to 5.4 for additional information.

3.1.16 *unit, n*—a single vacuum cleaner of the model being tested.

## 4. Significance and Use

4.1 The test results allow the comparison of the maximum air power available when no dirt has been introduced into the vacuum cleaning system, that is, a completely clean filter or an empty, clean dirt container.

## 5. Apparatus

5.1 *Plenum Chamber*—See Specification F431 or IEC 62885-2, Section 5.8.3.

5.2 *Water Manometers*, or equivalent instruments. One to measure from 0 in. to 6 in. (152.4 mm) in increments of 0.01 in. (0.254 mm), and one with increments of 0.1 in. (2.54 mm) for use in making measurements above 6 in. (152.4 mm). A single instrument having a resolution of 0.01 in. (0.254 mm) over the entire required range may be used instead of two separate instruments.

5.3 *Power analyzer*, to provide measurements accurate to within ±1 %.

5.4 *Barometer*, with an accuracy of ±0.05 in. (1.27 mm) of mercury, capable of measuring and displaying absolute barometric pressure, scale divisions 0.02 in. (0.51 mm) or finer.

5.4.1 Mercury barometers, in general, measure and display the absolute barometric pressure. Some corrections may be needed for temperature and gravity. Consult the owner's manual.

5.4.2 When purchasing an aneroid or electronic barometer, be sure to purchase one which displays the absolute barometric pressure, not the mean sea level equivalent barometric pressure value. These types of barometers generally have temperature compensation built into them and do not need to be corrected for gravity.

5.5 *Orifice Plates*—See Specification F431.

5.6 *Thermometer*—Solid-stem, ambient thermometer having a range from 18 °F to 89 °F (or –8 °C to +32 °C) with graduations in 0.2 °F (0.1 °C), conforming to the requirements for thermometer 63 °F (17 °C) as prescribed in Specification E1. As an alternative, thermometers S63F or S63C, as prescribed in Specification E2251, may be used. In addition, thermometric devices such as resistance temperature detectors (RTDs), thermistors, or thermocouples of equal or better accuracy may be used.

5.7 *Psychrometer*—Thermometers graduated in 0.2 °F (0.1 °C).

5.8 *Voltage-Regulator System*, to control the input voltage to the vacuum cleaner. The regulator system shall be capable of maintaining the vacuum cleaner's rated voltage ±1 % and rated frequency ±1 Hz having a wave form that is essentially sinusoidal with 3 % maximum harmonic distortion for the duration of the test.

5.9 *Orifice Adapter Tube*—See Fig. 1.

## 6. Sampling

6.1 A minimum of three units of the same model vacuum cleaner selected at random in accordance with good statistical practice, shall constitute the population sample.

6.1.1 To determine the best estimate of maximum air power for the population of the vacuum cleaner model being tested, the arithmetic mean of the maximum air power of the sample from the population shall be established by testing it to a 90 % confidence level within ±5 %.

6.1.2 Annex A2 provides a procedural example for determining the 90 % confidence level and when the sample size shall be increased.

NOTE 2—See Annex A2 for method of determining 90 % confidence level.

## 7. Test Vacuum Cleaners

7.1 *New Test Vacuum Cleaner*—Run the vacuum cleaner in at rated voltage ±1 % and rated frequency with filters in place for 1 h with a wide-open inlet (without hose).

7.2 *Used Test Vacuum Cleaners*—Recondition a used test vacuum cleaner; prior to the initial test run as follows:

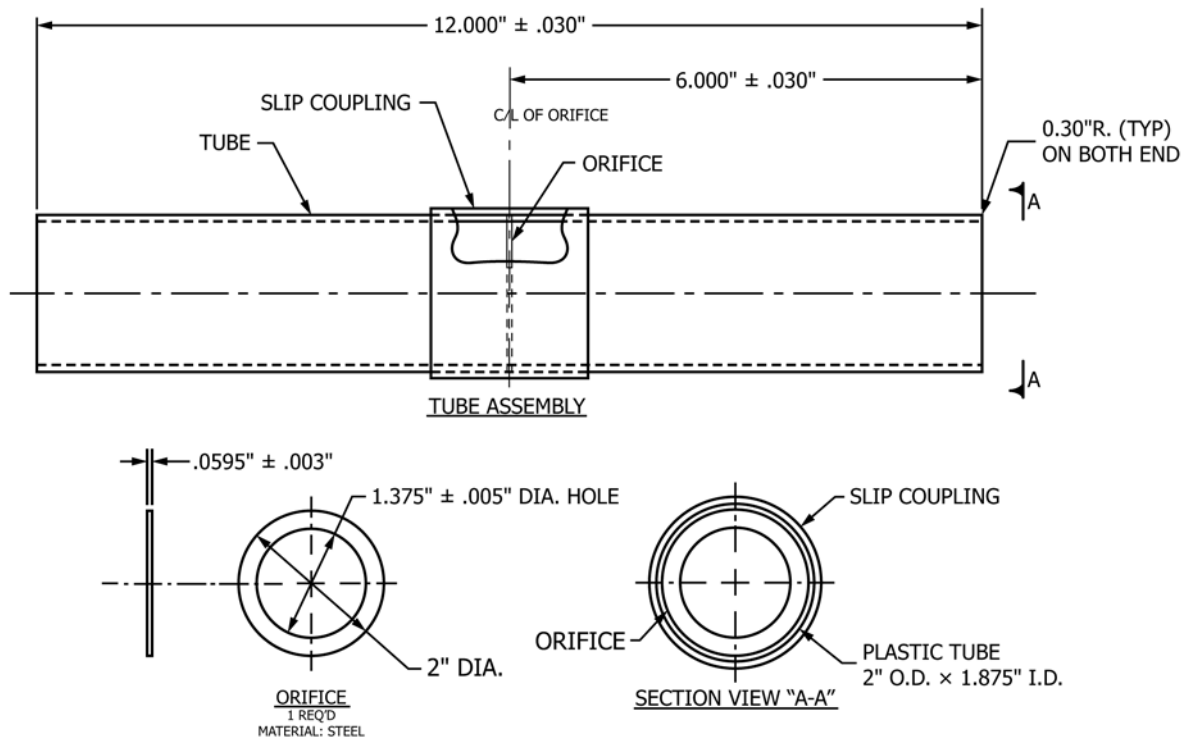

**TUBE AND ORIFICE ASSEMBLY**

NOTE:  
 1. MAKE SURE ALL BURRS ARE REMOVED BEFORE ASSEMBLY.  
 2. PLACE SLIP COUPLER ON TUBING HALFWAY AND GLUE  
 3. PLACE ORIFICE UP FLAT AGAINST TUBING.  
 4. PLACE OTHER PIECE OF TUBING INTO SLIP COUPLER AND GLUE.

**FIG. 1 Orifice Adapter Tube**

7.2.1 Thoroughly remove excess dirt from the vacuum cleaner. Without using tools for disassembly, clean the entire outer surface, brushes, nozzle chamber, ductwork, inside of the chamber surrounding the primary filter, and inside hose and wands.

7.2.2 For vacuum cleaners using disposable filters as the primary filters, use a new disposable primary filter from the manufacturer for each test. Install it as recommended by the vacuum cleaner manufacturer.

7.2.3 For vacuum cleaners using non-disposable dirt receptacles, empty in accordance with the manufacturer's instructions and clean the receptacle until its weight is within 0.07 oz (2 g) of its original weight and install it as recommended by the vacuum cleaner manufacturer.

7.2.4 For vacuum cleaners using non-disposable dirt receptacles, empty in accordance with the manufacturer's instructions and clean the receptacle until its weight is within 0.07 oz (2 g) of its original weight and install it as recommended by the vacuum cleaner manufacturer.

NOTE 3—It is preferable to conduct this test method on new test vacuum cleaners prior to any other ASTM test methods to avoid contamination that could cause performance variations.

7.3 *Test Vacuum Cleaner Settings*—If various settings are provided, set the motor speed setting or suction regulator using the manufacturer's specifications as provided in the instruction manual for normal operation. If a different setting is used, make a note of the deviation in the test report.

**8. Procedure**

8.1 *Preparation for Test:*

8.1.1 Prepare the test unit in accordance with Section 7. Set-up the test system as shown in Fig. 2. On the intake side, use an adapter terminating with the wall inlet valve. This wall inlet is to be the one specified for installation with the power unit being tested. All joints should be made in accordance with the manufacturer's specifications and be free of leaks. Insert into the wall valve a flexible cleaning hose as provided with the system. The hose assembly should be that which is offered normally with the particular unit being tested. For those systems, which provide for an external exhaust, connect 2 ft (0.6 m) of exhaust comprised of tubing and exhaust muffler, if a muffler is provided as part of the system.

8.1.2 Set the manometers to zero and check all instruments for proper operation.

8.1.3 Record the test station pressure and the dry-bulb and wet-bulb temperature readings within 6 ft (1.8 m) of the test area. Read the barometric pressure to the nearest 0.02 in. (0.51 mm) of mercury, and the dry-bulb and wet-bulb temperatures to the nearest 0.2 °F (or 0.1 °C).

8.1.3.1 The test area shall be free of major fluctuating temperature conditions due to air conditioners or air drafts that would be indicated by a thermometer at the immediate test area.

8.1.4 Connect the manometer or equivalent instrument to the plenum chamber.

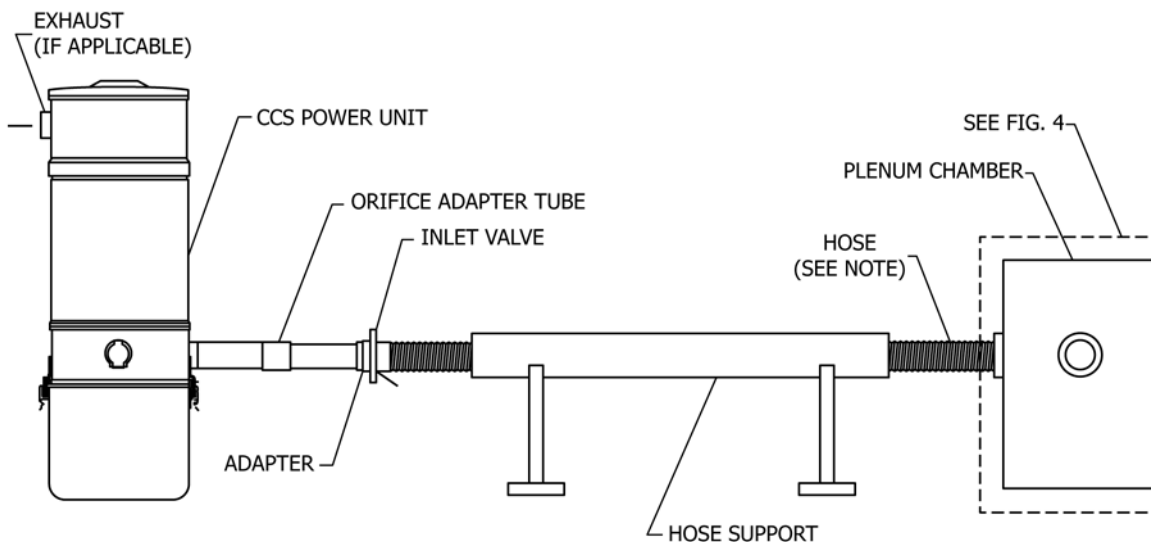

NOTE 1—Hose is to be supported in a straight line.  
**FIG. 2 Vacuum Cleaning System Test Set-up**

8.1.5 Connect a power analyzer.

8.2 Test Procedure:

8.2.1 Connect the hose assembly to the plenum chamber hose adapter and seal only this connection (see Fig. 3).

8.2.1.1 The end of the hose assembly should be inserted inside the hose connector adapter and be perpendicular to the plenum chamber.

8.2.1.2 The end of the hose assembly shall not project into the plenum chamber.

8.2.1.3 Any automatic bleed valve, which affects the air performance of the vacuum cleaner, shall not be defeated.

8.2.2 The hose should be supported and kept straight and horizontal over its entire length. Allowance should be made for the foreshortening of the hose assembly under the vacuum. Maintain the power unit and dirt canister in their normal operating orientation.

8.2.3 Operate the vacuum cleaner with no orifice plate inserted in the plenum chamber inlet at nameplate rated voltage  $\pm 1\%$  and frequency  $\pm 1$  Hz prior to the start of the test run to allow the unit to reach its normal operating temperature. For vacuum cleaners with dual nameplate voltage ratings, conduct testing at the highest voltage. Allow the unit to reach its normal operating temperature before each test run.

8.2.4 The vacuum cleaner is to be operated at its nameplate rated voltage  $\pm 1\%$  and frequency  $\pm 1$  Hz throughout the test. For vacuum cleaners with dual nameplate voltage ratings, conduct the test at the highest voltage.

8.2.4.1 Allow the vacuum cleaner to operate at the open orifice for 15 seconds minimum between test runs.

8.2.5 While operating the vacuum cleaner in accordance with 8.2.4, insert orifice plates sequentially into the orifice plate holder of the plenum chamber starting with the largest size orifice and following it with the next smaller orifice plate. Use the following orifice plates: 2.0, 1.5, 1.25, 1.0, 0.875, 0.75, 0.625, 0.5, 0.375, 0.25, 0.0 in. (50.8, 38.1, 31.7, 25.4, 22.2, 19.0, 15.8, 12.7, 9.5, 6.3 mm). The following optional orifice

plates also may be used: 2.5, 2.25, 1.75, 1.375, 1.125 in. (63.5, 57.2, 44.5, 34.9, 28.6 mm).

8.2.6 For each orifice plate, record the suction,  $h$ , and input power,  $P$ , in that order. All readings should be taken within 10 s of the orifice insertion. For orifices less than 0.750 in. allow the vacuum cleaner to operate at the open orifice for 1 to 2 min before inserting the next orifice.

8.2.6.1 Read the suction to the nearest graduation of the instrument. Readings should be taken as soon as the manometer reaches a true peak. When using a fluid type manometer, the liquid level may peak, drop, and peak again. The second peak is the true peak reading. A person conducting the test for the first time shall observe at least one run before recording data. See Specification F431 for instructions on how to minimize the overshoot (first peak) of the liquid level.

9. Calculation

9.1 Correction of Data to Standard Conditions:

9.1.1 Air Density Ratio—The density ratio,  $D_r$ , is the ratio of the air density at the time of test  $\rho_{test}$  to the standard air density,  $\rho_{std} = 0.075 \text{ lb/ft}^3$  ( $1.2014 \text{ kg/m}^3$ ). It is used to correct the vacuum and wattage readings to standard conditions. Find  $\rho_{test}$  ( $\text{lb/ft}^3$  or  $\text{kg/m}^3$ ) from standard psychometric charts or ASHRAE tables and calculate  $D_r$  as follows:

$$D_r = \frac{\rho_{test}}{\rho_{std}} \tag{1}$$

where:

$\rho_{test}$  = the air density at the time of test,  $\text{lb/ft}^3$  ( $\text{kg/m}^3$ ), and  
 $\rho_{std}$  = the standard air density,  $0.075 \text{ lb/ft}^3$  ( $1.2014 \text{ kg/m}^3$ ).

9.1.1.1 As an alternative, the following equation is intended to be used for correcting ambient conditions where the barometric pressure exceeds 27 in mercury and the dry-bulb and wet-bulb temperatures are less than 100 °F (37.8 °C); and, may be used as an alternate method of calculating  $D_r$  (see Appendix X1 for derivation and accuracy analysis).

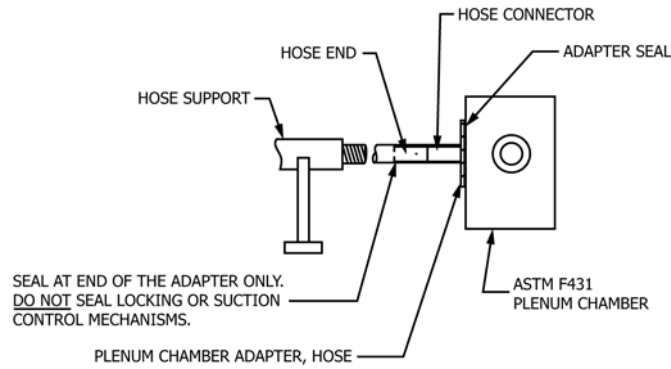

FIG. 3 Diagram of Hose and Adapter Connection

$$D_r = \frac{[17.68 B_t - 0.001978 T_w^2 + 0.1064 T_w + 0.0024575 B_t (T_d - T_w) - 2.741]}{T_d + 459.7} \quad (2)$$

where:

$B_t$  = test station pressure at time of test, inch of mercury,  
 $T_d$  = dry-bulb temperature at time of test, °F, and  
 $T_w$  = wet-bulb temperature at time of test, °F.

9.1.2 *Corrected Suction*—Corrected suction,  $h_s$ , is the manometer reading,  $h$ , times the correction factor,  $C_s$ , as follows:

$$h_s = C_s h \quad (3)$$

9.1.2.1 For series universal motors (6) the correction factor,  $C_s$ , is calculated as follows:

$$C_s = 1 + 0.667(1 - D_r) \quad (4)$$

9.1.2.2 This test method does not have any formulas available for correcting input power for any other type of motor (permanent magnet, induction, etc.).

9.1.3 *Corrected Input Power*—Corrected input power,  $P_s$ , expressed in watts, is the wattmeter reading,  $P$ , times the correction factor,  $C_p$ , as follows:

$$P_s = C_p P \quad (5)$$

9.1.3.1 For series universal motors the correction factor,  $C_p$ , is calculated as follows:

$$C_p = 1 + 0.5(1 - D_r) \quad (6)$$

9.1.3.2 This test method does not have any formulas available for correcting input power for any other types of motor (permanent magnet, induction, etc.).

9.2 *Corrected Airflow*—Calculate the corrected airflow,  $Q$ , expressed in cubic feet per minute (see Note 4 and Appendix X2) as follows:

$$Q = 21.844 D^2 K_1 \sqrt{h_s} \quad (7)$$

where:

$Q$  = corrected flow, cfm,  
 $D$  = orifice diameter, in.,  
 $K_1$  = constant (dimensionless) orifice flow coefficients for orifices in the plenum chamber. See Table 1 for values for each orifice. See Ref (1) for the derivation of these flow coefficients, and  
 $h_s$  = corrected suction, water, in.

TABLE 1 Orifice Flow Coefficient Equations ( $K_1$ )

NOTE 1— $K_1$  was determined experimentally using an ASTM Plenum Chamber (see Specification F431) and an ASME Flowmeter (1).

NOTE 2—Equations for  $K_1$  in terms of  $B_t$  and  $h$ , are given in Appendix X6.

Orifice Diameter, in. (mm)	Orifice Flow Coefficient Equation <sup>A</sup>
0.250 (6.3)	$K_1 = \frac{0.5575r - 0.5955}{r - 1.0468}$
0.375 (9.5)	$K_1 = \frac{0.5553r - 0.5754}{r - 1.0263}$
0.500 (12.7)	$K_1 = \frac{0.5694r - 0.5786}{r - 1.0138}$
0.625 (15.8)	$K_1 = \frac{0.5692r - 0.5767}{r - 1.0104}$
0.750 (19.0)	$K_1 = \frac{0.5715r - 0.5807}{r - 1.0138}$
0.875 (22.2)	$K_1 = \frac{0.5740r - 0.5841}{r - 1.0158}$
1.000 (25.4)	$K_1 = \frac{0.5687r - 0.5785}{r - 1.0146}$
1.125 (28.6)	$K_1 = \frac{0.5675r - 0.5819}{r - 1.0225}$
1.250 (31.7)	$K_1 = \frac{0.5717r - 0.5814}{r - 1.0152}$
1.375 (34.9)	$K_1 = \frac{0.5680r - 0.5826}{r - 1.0235}$
1.500 (38.1)	$K_1 = \frac{0.5719r - 0.5820}{r - 1.0165}$
1.750 (44.5)	$K_1 = \frac{0.5695r - 0.5839}{r - 1.0235}$
2.000 (50.8)	$K_1 = \frac{0.5757r - 0.5853}{r - 1.0157}$
2.250 (57.2)	$K_1 = \frac{0.5709r - 0.5878}{r - 1.0279}$
2.500 (63.5)	$K_1 = \frac{0.5660r - 0.59024}{r - 1.0400}$

$$A_r = \frac{B_t (0.4912) - h(0.03607)}{B_t (0.4912)}$$

where:

$B_t$  = test station pressure at time of test, in. of mercury, and  
 $h$  = uncorrected suction (manometer reading), in. of water.

NOTE 4—For the corrected airflow expressed in liters per second, use the following equation:

$$Q = 10.309D^2K_1\sqrt{h_s} \quad (8)$$

where:

- $Q$  = corrected flow, L/s,
- $D$  = orifice diameter, m,
- $K_1$  = constant (dimensionless),
- $h_s$  = corrected suction, Pa.

9.3 *Air Power*—Calculate the air power,  $AP$ , in watts, as follows:

$$AP = 0.117354 (Q)(h_s) \quad (9)$$

where:

- $AP$  = air power,  $W$ ,
- $Q$  = corrected flow, cfm, and
- $h_s$  = corrected suction, inch of water (see [Appendix X3](#) for derivation).

9.4 *Maximum Air Power*—Determine the maximum air power using the method in [Annex A1](#).

## 10. Report

10.1 For each vacuum cleaner sample from the population being tested, report the following information:

10.1.1 Manufacturer's name and product model name or number, or both.

10.1.2 Type of filtration; that is, paper bag, cloth bag, foam filter, centrifugal, etc.

10.1.3 The corrected input power, corrected vacuum, corrected airflow, and air power for each orifice.

10.1.4 Manufacturer's parts, catalog, or model number of the ductwork, fittings, and flexible cleaning hose assembly used in the test.

10.1.5 Calculated or measured maximum air power, whichever is greater.

## 11. Precision and Bias

11.1 The following precision statements are based on inter-laboratory tests involving nine laboratories and four units.

11.2 The statistics have been calculated as recommended in Practice [E691](#).

11.3 The following statements regarding repeatability limit and reproducibility limit are used as directed in Practice [E177](#).

11.4 The Coefficients of Variation of repeatability and reproducibility of the measured results have been derived from nine sets of data, where each set has been performed by a single analyst within each of the nine laboratories on two separate days using the same unit test.<sup>6</sup>

11.5 *Repeatability (Single Operator and Laboratory; Multiday Testing)*—The ability of a single analyst to repeat the test within a single laboratory.

<sup>6</sup> Complete data on the round-robin test is available from ASTM Headquarters. Request RR:F11-1003. Contact ASTM Customer Service at [service@astm.org](mailto:service@astm.org).

**TABLE 2 Repeatability and Reproducibility**

Coefficient of Variation, CV % <sub>r</sub>	Repeatability Limit, $r$	Coefficient of Variation, CV % <sub>R</sub>	Reproducibility Limit, $R$
1.5	4.3	9.0	25.1

11.5.1 The expected coefficient of variation of the measured results within a laboratory, CV %<sub>r</sub>, has been found to be the respective values listed in [Table 2](#).

11.5.2 The 95 % repeatability limit within a laboratory,  $r$ , has been found to be the respective values listed in [Table 2](#), where  $r = 2.8$  (CV %<sub>r</sub>).

11.5.3 With 95 % confidence, it can be stated that within a laboratory a set of measured results derived from testing a unit should be considered suspect if the difference between any two of the three values is greater than the respective value of the repeatability limit,  $r$ , listed in [Table 2](#).

11.5.4 If the absolute value of the difference of any pair of measured results from three test runs performed within a single laboratory is not equal to or less than the respective repeatability limit listed in [Table 2](#), that set of test results shall be considered suspect.

11.6 *Reproducibility (Multiday Testing and Single Operator Within Multilaboratories)*—The ability to repeat the test with multiple laboratories.

11.6.1 The expected coefficient of variation of reproducibility of the average of a set of measured results between multiple laboratories, CV %<sub>R</sub>, has been found to be the respective values listed in [Table 2](#).

11.6.2 The 95 % reproducibility limit within a laboratory,  $R$ , has been found to be the respective values listed in [Table 2](#), where  $R = 2.8$  (CV %<sub>R</sub>).

11.6.3 With 95 % confidence, it can be stated that the average of the measured results from a set of three test runs performed in one laboratory, as compared to a second laboratory, should be considered suspect if the difference between those two values is greater than the respective values of the reproducibility limit,  $R$ , listed in [Table 2](#).

11.6.4 If the absolute value of the difference between the average of the measured results from the two laboratories is not equal to or less than the respective reproducibility limit listed in [Table 2](#), the set of results from both laboratories shall be considered suspect.

11.7 *Bias*—No justifiable statement can be made on the bias of this test method for testing the properties listed. The true values of the properties cannot be established by acceptable referee methods.

## 12. Keywords

12.1 airflow; air performance; air power; residential central vacuum cleaners; suction; suction power; vacuum cleaners

**ANNEXES**
**(Mandatory Information)**
**A1. MATHEMATICAL METHOD FOR DETERMINING MAXIMUM AIR POWER POINT**

A1.1 The following, second degree polynomial equation, is assumed to provide the best mathematical approximation of the air power versus airflow relationship (see Ref (4) for additional information).

$$Y = A_1 + A_2X + A_3X^2 \quad (\text{A1.1})$$

where:

$Y$  = air power ( $AP$ ),  
 $X$  = airflow ( $Q$ ), and  
 $A_1, A_2,$  and  $A_3$  = arbitrary constants.

A1.1.1 Use  $X$  and  $Y$  values obtained from only five specific orifices selected as follows:

A1.1.1.1 Using the test data, determine the orifice size that produced the highest air power value.

A1.1.1.2 Use the air power and airflow values at this orifice, and the next two smaller and the next two larger orifices in the following computations.

A1.1.1.3 If the highest air power value calculated from the observed data is at the 2.0 in. (50.8 mm) orifice or larger, then use the air power and airflow values from the five largest orifices.

A1.2 To determine the values of  $A_1, A_2,$  and  $A_3,$  use the  $X$  and  $Y$  values obtained from the five specified orifices and solve the following set of normalized equations:

$$\sum Y_i = NA_1 + A_2 \sum X_i + A_3 \sum X_i^2 \quad (\text{A1.2})$$

$$\sum X_i Y_i = A_1 \sum X_i + A_2 \sum X_i^2 + A_3 \sum X_i^3 \quad (\text{A1.3})$$

$$\sum X_i^2 Y_i = A_1 \sum X_i^2 + A_2 \sum X_i^3 + A_3 \sum X_i^4 \quad (\text{A1.4})$$

where:

$N$  = 5 (number of orifices selected),  
 $I$  = 1 to  $N,$  and  
 $X_i$  and  $Y_i$  = the values obtained during testing ( $X_1Y_1, X_2Y_2,$  ...  $X_NY_N$ ) at the five orifices specified in A1.1.1.

A1.3 Setting the derivative of Eq A1.1 equal to zero and solving for  $X$  will determine the value of  $X_m$  where  $Y$  is at its maximum value ( $Y_{max}$ ) as follows:

$$\frac{dy}{dx} = \frac{d}{dx} [A_1 + A_2X + A_3X^2] = 0 \quad (\text{A1.5})$$

$$\frac{dy}{dx} = A_2 + 2A_3X = 0$$

Substitute  $X_m$  as the value of  $X$  at  $Y_{max}$  and solve for  $X_m$ :

$$X_m = -\frac{A_2}{2A_3} \quad (\text{A1.6})$$

Substituting this value of  $X_m,$  and  $A_1, A_2,$  and  $A_3,$  into Eq A1.1 will determine the value of  $Y_{max}$  ( $AP_{max}$ ) as follows:

$$Y_{max} = A_1 + A_2X_m + A_3X_m^2 \quad (\text{A1.7})$$

A1.4 Calculate the goodness of fit,  $R$  (correlation coefficient), as follows:

$$R = 1 - \frac{\sum (Y_{i \text{ OBS}} - Y_{i \text{ CAL}})^2}{\sum (Y_{i \text{ OBS}} - Y_{\text{OBS}})^2} \quad (\text{A1.8})$$

where:

$$Y_{i \text{ CAL}} = A_1 + A_2X_{i \text{ OBS}} + A_3X_{i \text{ OBS}}^2 \quad (\text{A1.9})$$

and:

$$Y_{\text{OBS}} = \frac{1}{N} \sum Y_{i \text{ OBS}} \quad (\text{A1.10})$$

and:

$i$  = 1 to  $N$  orifices used in 8.2,

$OBS$  = observed data,

$CAL$  = calculated data, and

$Y_{i \text{ OBS}}$  = is the air power ( $AP$ ) obtained from the calculations in 9.3 for the corresponding value  $X_{i \text{ OBS}}$  (airflow,  $Q$ ) at any of the  $N$  orifices selected.

A1.4.1 If  $R$  is not greater than or equal to 0.900, the test must be performed again and the new set of data used.

A1.4.2 The measured or calculated value for maximum air power shall be recorded, whichever is greater.