



Designation: ~~D850 – 18~~^{e1} D850 – 21

Standard Test Method for Distillation of Industrial Aromatic Hydrocarbons and Related Materials¹

This standard is issued under the fixed designation D850; the number immediately following the designation indicates the year of original adoption or, in the case of revision, the year of last revision. A number in parentheses indicates the year of last reapproval. A superscript epsilon (ϵ) indicates an editorial change since the last revision or reapproval.

This standard has been approved for use by agencies of the U.S. Department of Defense.

^{e1} NOTE—Editorial corrections were made in 12.1 and 12.2 in September 2018.

1. Scope*~~Scope~~

1.1 This test method covers the distillation of industrial aromatic hydrocarbons and related materials of relatively narrow boiling ranges from 30 to 250°C. **Warning**—This test method is not applicable for styrene which will exothermically polymerize during the distillation process.

1.2 The following applies to all specified limits in this test method: for the purposes of determining conformance to this test method, an observed or calculated value shall be rounded off “to the nearest unit” in the last right-hand digit used in expressing the specification limit, in accordance with the rounding-off method of Practice E29.

1.3 **Warning**—Mercury has been designated by EPA and many state agencies as a hazardous material that can cause central nervous system, kidney and liver damage. Mercury, or its vapor, may be hazardous to health and corrosive to materials. Caution should be taken when handling mercury and mercury-containing products. See the applicable product Safety Data Sheet (SDS) for details and EPA’s website (<http://www.epa.gov/mercury/faq.htm>) for additional information. Users should be aware that selling mercury or mercury-containing products, or both, in your state may be prohibited by state law. ~~Warning—Mercury has been designated by EPA and many state agencies as a hazardous material that can cause central nervous system, kidney and liver damage. Mercury, or its vapor, may be hazardous to health and corrosive to materials. Caution should be taken when handling mercury and mercury-containing products. See the applicable product Safety Data Sheet (SDS) for details and EPA’s website (<http://www.epa.gov/mercury/faq.htm>) for additional information. Users should be aware that selling mercury or mercury-containing products, or both, in your state may be prohibited by state law.~~

1.4 The values stated in SI units are to be regarded as standard. No other units of measurement are included in this standard.

1.5 *This standard does not purport to address all of the safety concerns, if any, associated with its use. It is the responsibility of the user of this standard to establish appropriate safety, health, and environmental practices and determine the applicability of regulatory limitations prior to use.* For specific hazard statements, see 6.5.2, 6.6.1, and Section 7.

1.6 *This international standard was developed in accordance with internationally recognized principles on standardization established in the Decision on Principles for the Development of International Standards, Guides and Recommendations issued by the World Trade Organization Technical Barriers to Trade (TBT) Committee.*

¹ This test method is under the jurisdiction of ASTM Committee D16 on Aromatic, Industrial, Specialty and Related Chemicals and is the direct responsibility of Subcommittee D16.04 on Instrumental Analysis.

Current edition approved June 1, 2018Feb. 1, 2021. Published June 2018February 2021. Originally approved in 1945. Last previous edition approved in 20162018 as D850 – 16.D850 – 18^{e1}. DOI: 10.1520/D0850-18E01.10.1520/D0850-21.

*A Summary of Changes section appears at the end of this standard

2. Referenced Documents

2.1 *ASTM Standards:*²

- D1078 Test Method for Distillation Range of Volatile Organic Liquids
- D3437 Practice for Sampling and Handling Liquid Cyclic Products
- D4790 Terminology of Aromatic Hydrocarbons and Related Chemicals
- D6809 Guide for Quality Control and Quality Assurance Procedures for Aromatic Hydrocarbons and Related Materials
- E1 Specification for ASTM Liquid-in-Glass Thermometers
- E29 Practice for Using Significant Digits in Test Data to Determine Conformance with Specifications
- E133 Specification for Distillation Equipment
- E220 Test Method for Calibration of Thermocouples By Comparison Techniques
- E691 Practice for Conducting an Interlaboratory Study to Determine the Precision of a Test Method

2.2 *Other Document:*

- OSHA Regulations, 29 CFR paragraphs 1910.1000 and 1910.1200³

3. Terminology

3.1 *Definitions:*

- 3.1.1 See Terminology D4790 for definitions of terms used in this test method.

4. Summary of Test Method

4.1 The distillation of a 100-mL sample of industrial aromatic hydrocarbons and related materials is carried out via a carefully controlled distillation wherein temperature readings are noted for the first drop of distillate and when 5, 10, and each additional 10 up to 90, and 95 % of the sample has distilled over. The temperature corresponding to the dry point is also noted.

5. Significance and Use

5.1 This test method is suitable for setting specifications, for use as an internal quality control tool, and for use in development or research work on industrial aromatic hydrocarbons and related materials.

5.2 This test method gives a broad indication of general purity and can also indicate presence of excessive moisture. It will not differentiate between products of similar boiling range.

6. Apparatus

6.1 *Distillation Flask*—A standard 200-mL side-tube, heat-resistant glass distillation flask as shown in Fig. 1, conforming to the following dimensions:

Diameter of bulb, outside, mm	76 ± 1.5
Diameter of neck, inside, mm	21 ± 1
Height of flask, outside, mm	179 ± 3
Vertical distance from bottom of bulb outside to bottom of vapor-tube opening in neck, mm	120 ± 3
Length of side tube, mm	100 ± 3
Diameter of side tube, outside, mm	7 ± 0.5
Angle of side tube with vertical axis of bulb and neck, °	75 ± 3

The flask does not comply with Flask C of Specification E133.

6.2 *Temperature Measurement Devices:*

6.2.1 *Manual Distillation Thermometer*—The ASTM Solvents Distillation Thermometer used in the test shall be as prescribed in the specifications for the material being tested. If no thermometer is specified in the material specification, select one from Table

² For referenced ASTM standards, visit the ASTM website, www.astm.org, or contact ASTM Customer Service at service@astm.org. For *Annual Book of ASTM Standards* volume information, refer to the standard's Document Summary page on the ASTM website.

³ Available from U.S. Government Printing Office Superintendent of Documents, 732 N. Capitol St., NW, Mail Stop: SDE, Washington, DC 20401, http://www.access.gpo.gov.

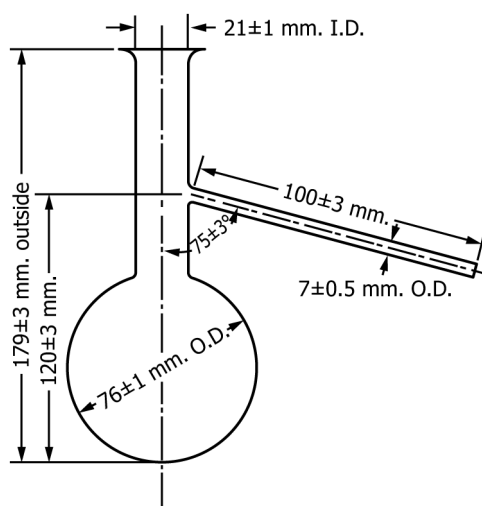

FIG. 1 Distillation Flask

1 with the smallest graduations that will cover the entire distillation range of the material being tested. Table 1 lists several ASTM solvents distillation thermometers which are suitable for testing industrial aromatic hydrocarbons, and which meet the requirements of Specification E1.

6.2.2 *Automatic Distillation Temperature Sensor*—Temperature measurement systems using thermocouples or resistance thermometers, otherwise referred to as the “temperature measuring devices,” must exhibit the same temperature lag and accuracy as the equivalent mercury glass thermometer. Confirmation of the calibration of these temperature sensors is to be done at regular intervals. This may be accomplished as prescribed in Test Method E220, or some similar means using a precision resistance decade box. Another technique is to distill pure toluene and compare the temperature indicated by the thermocouple or resistance thermometer with that shown by the thermometer. When installing a new automatic distillation analyzer, a toluene sample with a known distillation range of approximately 1.0°C must be used to verify the dry point and distillation range.⁴ It is recommended that such a material be used when replacing a temperature measuring device. Alternatively a material of known distillation range and dry point may be used when replacing a temperature measuring device.

6.2.2.1 *Automatic Distillation Temperature Sensor Centering Device*—The temperature sensor shall be mounted through a snug-fitting device designed to mechanically center the sensor in the neck of the flask. The use of a cork or silicone stopper with a hole drilled through the center is not acceptable for this purpose. Examples of acceptable centering devices are shown in Fig. 2.

6.2.2.2 The electronic circuitry or algorithms, or both, used shall include the capability to simulate the temperature lag of a mercury-in-glass thermometer. For that reason the known toluene sample with a distillation range of approximately 1.0°C must be used to verify the algorithm and dampening software.

TABLE 1 ASTM Thermometers for Distillation Test of Industrial Aromatic Hydrocarbons

ASTM Thermometer No.	Name	Range, °C	Subdivision, °C
39C	solvents distillation	48 to 102	0.2
40C	solvents distillation	72 to 126	0.2
41C	solvents distillation	98 to 152	0.2
42C	solvents distillation	95 to 255	0.5
102C	solvents distillation	123 to 177	0.2
103C	solvents distillation	148 to 202	0.2
104C	solvents distillation	173 to 227	0.2
105C	solvents distillation	198 to 252	0.2
106C	solvents distillation	224 to 276	0.2
111C	solvents distillation	170 to 250	0.2

⁴ Such a material is available from Spectrum Quality Standards.

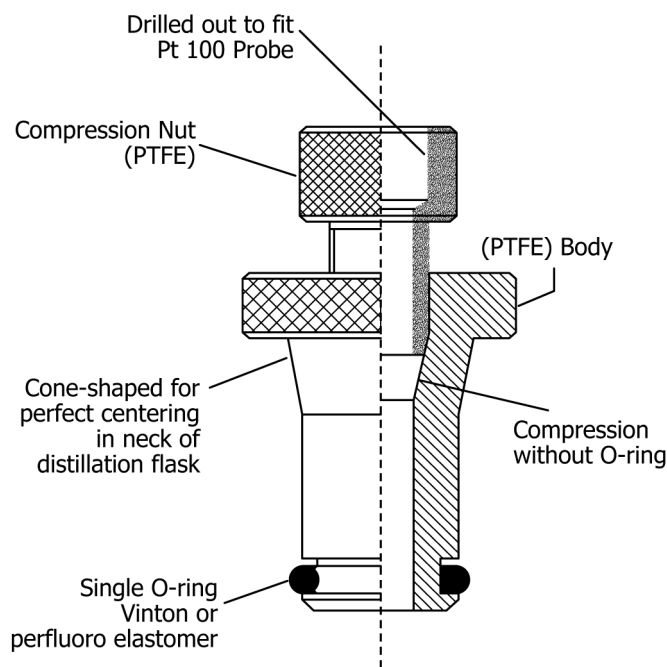

FIG. 2 Examples of Centering Device Designs for Straight-Bore Neck Flasks

6.2.2.3 Alternatively, the sensor can also be placed in a casing with the tip of the sensor covered, so that the assembly, because of its adjusted thermal mass and conductivity, has a temperature lag similar to that of a mercury-in-glass thermometer.

NOTE 1—In a region where the temperature is changing rapidly during the distillation, the temperature lag of a thermometer can be as much as 3 s.

6.3 Condenser and Cooling Bath:

6.3.1 Manual Distillation Condenser and Cooling Bath:

6.3.1.1 The manual distillation condenser and cooling bath shall be as specified in Section 5, and Fig. 1 of Specification E133.

6.3.1.2 As an alternative, the condenser tube may consist of a straight glass tube 600 to 610 mm in length and 12 mm in inside diameter, of standard wall thickness (about 1.25 mm) with the exit end cut off square and ground flat. It shall be set in a cooling trough so that at least 380 mm of the tube is in contact with the water. Clearance between the condenser tube and any parallel side of the trough shall be not less than 19 mm. The water in the cooling trough shall be maintained at 10 to 20°C. This may be done by adding ice to the water or by circulating chilled water through the trough. The trough shall be so mounted that the condenser tube is set at an angle of 75° with the vertical. To minimize the turbulence in the receiver during the run, provisions shall be made to enable the flow of the distillate to run down the side of the receiving cylinder. This can be accomplished by using a drip-deflector, which is attached to the outlet of the tube.

6.3.2 Automatic Distillation and Cooling Bath—The automatic distillation and cooling bath shall be as specified in Section 5, Fig. 2 of Specification E133.

6.4 Distillation Receiver:

6.4.1 Manual Distillation Receiver—A graduate of the cylindrical type, of uniform diameter, with a pressed or molded base and a lipped top. The cylinder shall be marked to contain 100 mL, and the 0 to 100 mL receiver portion shall be not less than 178 nor more than 203 mm in length. It shall be graduated in single millilitres and each fifth mark shall be distinguished by a longer line. It shall be numbered from the bottom up at intervals of 10 mL. The overall height of the receiver shall not be less than 248 nor more than 260 mm. The graduations shall not be in error by more than 1 mL at any point on the scale. The bottom 1-mL graduation may be omitted. The receiver complies with Section 9, Graduate B Fig. 4, of Specification E133.

6.4.2 *Automatic Distillation Receiver*—A receiver to be used with measurements in accordance with the instrument manufacturer and conform to the physical specifications described in this section, with the exception of the graduations.

6.4.2.1 *Automatic Distillation Level Follower*—For automatic apparatus, the level follower or recording mechanism of the apparatus will have a resolution of 0.1 mL with an accuracy of $\pm 1 \text{ mL}$. The calibration of the assembly should be confirmed according to the manufacturer's instructions at regular intervals. The typical calibration procedure involves verifying the output with the receiver containing 5 and 100 mL of material respectively.

6.5 *Flask Support Assembly:*

6.5.1 *For Units Using Electric Heaters*—The assembly consists of an adjustable system onto which the electric heater is mounted with provision for placement of a flask support board (see 6.5.2) above the electric heater. The whole assembly is adjustable from the outside of the shield.

6.5.2 *Flask Support Board*—The flask support board shall be constructed of ceramic or other heat-resistant material with a centrally located opening. For tests of benzene and toluene, the opening shall be 25 mm in diameter; for tests of materials boiling above toluene but mostly below 145°C, the opening shall be 38 mm in diameter, and for higher boiling materials, it shall be 50 mm in diameter. The flask support board shall be of sufficient dimension to ensure that thermal heat to the flask only comes from the central opening and that extraneous heat to the flask other than through the central opening is minimized. (~~Warning~~—~~Warning~~—Heat resistant-containing materials shall not be used in the construction of the flask support board.)

6.5.3 *For Units Using Bunsen Burner*—The flask support board is approximately 50 mm higher than the top of the burner.

6.6 *Heater:*

6.6.1 *Manual Distillation Heater*—An electric heater or a bunsen burner, fully adjustable and capable of giving sufficient heat to distill the product at the required rate. When a bunsen burner is used, as described in 7.1 and Fig. 1 of Specification E133, the burner shall be adjusted so as to produce an entirely blue flame. (~~Warning~~—~~Warning~~—Superheating—Superheating of the flask can cause erroneous results and is more likely to occur with electric heaters than with bunsen burners as heat sources. This problem is discussed in the section on Preparation of Apparatus in Test Method D1078.)

7. Hazards

iTech Standards
ASTM D850-21
<https://standards.iteh.ai/catalog/standards/sist/fba6072a-8dd7-440d-bfc4-9aae050c7c03/astm-d850-21>

7.1 Consult current OSHA regulations and supplier's Safety Data Sheets, and local regulations, for all materials used in this test method.

8. Sampling

8.1 Sampling should follow safe rules in order to adhere to all safety precautions as outlined in the latest OSHA regulations. Refer to Practice D3437 for proper sampling and handling of aromatic hydrocarbons analyzed by this test method.

8.2 The sample under test shall be transparent and free of separated water. Any separated water may ordinarily be eliminated by care in pouring the 100-mL specimen (10.1) into the graduated cylinder. If necessary, any separated water or cloudiness may be removed by filtration, in which case the following precautions shall be taken: Use a soft paper through which the specimen filters rapidly, avoid drafts, cover the funnel with a watch glass, and filter at least 200 mL from which to take the 100 mL for distillation. Dehydration (that is, removal of dissolved water) is not permissible. Note, however, that certain materials, especially benzene, may absorb traces of water that can be significant with respect to this test. When it can be shown that failure to pass this distillation test is due to the presence of dissolved water, it shall be permissible, if mutually agreeable to the purchaser and the seller, to dry the specimen by any method agreed to by both the purchaser and the seller.

9. Assembly of Apparatus

9.1 *Manual Distillation Apparatus:*

9.1.1 Remove any residual liquid in the condenser tube by swabbing with a piece of lint-free cloth attached to a cord or wire.

9.1.2 Assemble the apparatus. Mount the flask on the insulation board of appropriate dimensions, with the side tube extending through a tightly fitting silicone or cork stopper about 50 mm into the condenser tube.

9.1.3 Support the distillation thermometer in the neck of the flask by means of a cork or silicone stopper with the thermometer vertical and centered in the neck of the flask and in such a position that the top of the bulb (or top of contraction bulb if present) is level with the lowest point of juncture between the side tube and the neck of the flask (see Fig. 3).

9.1.4 Place the burner directly under the center of the hole in the insulation board.

9.2 *Automatic Distillation Apparatus*—For assembly of automatic distillation apparatus, consult the instrument manufacturer’s operating manual.

NOTE 2—The centering device must be as stated in 6.2.2.1 (Fig. 2).

9.3 Carefully measure a 100-mL specimen of the material to be tested in the 100-mL graduated cylinder at room temperature and transfer to the distillation flask, draining the cylinder at least 15 s. This is preferably done before mounting the flask in position, in order to prevent liquid from entering the side arm. Do not rinse out the graduated cylinder used to measure the sample for distillation, but place under the lower end of the condenser tube to receive the distillate.

9.4 Fit the flask vapor tube, provided with a snug fitting silicone rubber stopper, tightly into the condenser tube. Adjust the flask in a vertical position so that the vapor tube extends into the condenser tube for a distance of 25 to 50 mm (1 to 2 in.). Raise and adjust the flask support board to fit snugly against the bottom of the flask.

9.5 Place the cylinder which was used to measure the charge, without drying, into its position under the lower end of the condenser tube so that the end of the condenser tube is centered in the graduate and extends in for a distance of at least 25 mm (1 in.).

10. Procedure

10.1 *Manual Distillation Procedure:*

10.1.1 Connect the flask to the condenser apparatus as described in Section 9. Fit the thermometer to the flask as described in 9.1.

10.1.2 Heat the flask slowly, especially after boiling has begun, so as to allow the mercury column of the thermometer to become fully expanded before the first drop distills over. Regulate the rate of heating so that the ring of condensing vapor on the wall of the flask reaches the lower edge of the side arm in not less than 90 s, and preferably approximately 120 s, from the start of the

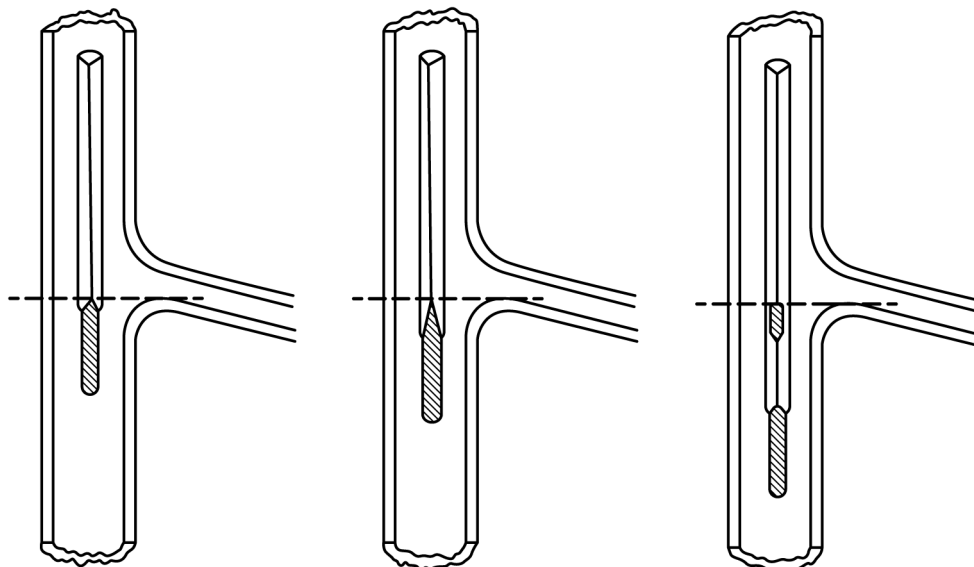

FIG. 3 Position of Thermometer in Measuring Device in Distillation Flask

rise of the vapor ring. To properly set up the distillation rate of the run, the total time from the start of heating until the first drop falls into the receiver should be not less than 5 nor more than 10 min and the time from initial boiling point to 5 % recovered should be 60 to 100 seconds. Avoid major changes in heating rate. Even operation is best gained through experience with the method. When distillation starts, adjust the receiver to allow condensation to flow down its inner wall to prevent loss by spattering; then adjust the heater to continue the distillation at the rate of 5 to 7 mL/min (about 2 drops/s). Maintain this rate, and continue the distillation to dryness. The total yield of distillate when testing close boiling benzene, toluene, and xylenes shall be not less than 97 %, and when testing wider boiling refined products and light oils, shall be not less than 95 %; otherwise, the test shall be repeated.

10.1.3 Take the temperature reading when the first drop of distillate falls into the receiving cylinder and report as the initial boiling point (IBP). Record when 50 % of the sample has distilled over as 50 % DP. Take a final reading when the liquid just disappears from the lowest point in the flask, and report this reading as the dry point temperature (DPT). When testing crude materials, a decomposition point, rather than a dry point, may be obtained. When a decomposition point is reached at the end of a distillation, the temperature will frequently cease to rise and begin to fall. In this case, take the temperature at the decomposition point as the maximum temperature observed. The decomposition point may also be indicated by the appearance of heavy fumes in the flask. Should that occur, record the temperature at the time the bulb of the flask becomes substantially full of fumes. If a decomposition rather than a dry point is observed, so note when recording results.

10.2 Automatic Distillation Procedure:

10.2.1 Connect the distillation flask to the automatic distillation equipment as described in 9.2. Fit the temperature measuring device to the flask for automatic distillation equipment according to the manufacturer's instructions.

10.3 *Barometer Reading and Temperature of the Barometer*—The observed barometric pressure shall be corrected by reference to standard tables and reported in terms of millimetres of mercury at 0°C.

11. Calculations

11.1 If the overall distillation range of the sample does not exceed 2°C, a combined correction for thermometer inaccuracy and barometric press shall be made.

$$C_1 = A - 50 \% DP$$

$$IBP \text{ corr} = IBP + C_1$$

$$50 \% DP \text{ corr} = 50 \% DP + C_1$$

$$DPT \text{ corr} = DPT + C_1$$

$$\text{Distillation range corr} = DPT \text{ corr} - IBP \text{ corr}$$

A = boiling point of material from **Table 2**

C₁ = correction factor

11.2 For samples with a distillation range greater than 2.0°C:

11.2.1 *Thermometer Inaccuracy*—This correction shall be obtained by calibration of the thermometer used in the test and applied to the observed thermometer readings.

11.2.2 *Barometer Reading and Temperature of the Barometer*—The observed barometric pressure shall be corrected by reference to standard tables and reported in terms of millimetres of mercury at 0°C.

11.2.3 *Variation from Standard Barometric Pressure*—This correction shall be applied to the observed temperature after correcting for inaccuracy of the thermometer and is determined by the following equation:

TABLE 2 Boiling Points of Hydrocarbons

	Boiling Point, °C
Cyclohexane	80.7
Benzene	80.1
Ethylbenzene	136.2
Pyridine	115.5
Toluene	110.6
<i>m</i> -Xylene	139.1
<i>o</i> -Xylene	144.4
<i>p</i> -Xylene	138.3