



Designation: C730 – 98 (Reapproved 2021)

Standard Test Method for Knoop Indentation Hardness of Glass¹

This standard is issued under the fixed designation C730; the number immediately following the designation indicates the year of original adoption or, in the case of revision, the year of last revision. A number in parentheses indicates the year of last reapproval. A superscript epsilon (ϵ) indicates an editorial change since the last revision or reapproval.

1. Scope

1.1 This test method covers the determination of the Knoop indentation hardness of glass and the verification of Knoop indentation hardness testing machines using standard glasses.

1.2 *This standard does not purport to address all of the safety concerns, if any, associated with its use. It is the responsibility of the user of this standard to establish appropriate safety, health, and environmental practices and determine the applicability of regulatory limitations prior to use.*

1.3 *This international standard was developed in accordance with internationally recognized principles on standardization established in the Decision on Principles for the Development of International Standards, Guides and Recommendations issued by the World Trade Organization Technical Barriers to Trade (TBT) Committee.*

2. Referenced Documents

2.1 *ASTM Standards:*²

E4 Practices for Force Verification of Testing Machines

E384 Test Method for Microindentation Hardness of Materials

3. Terminology

3.1 *Definitions of Terms Specific to This Standard:* Definitions of Terms Specific to This Standard

3.1.1 *Knoop hardness number (KHN)*—a number obtained by dividing the applied load in kilograms-force (kgf) by the projected area of the indentation in square millimetres (mm^2), computed from the measured long diagonal of the indentation and the included edge angles of the diamond; it is assumed that the indentation is an imprint of the undeformed indenter.

3.1.1.1 The Knoop hardness number (KHN) is computed as follows:

$$\text{KHN} = (P/A_p) = (P/d^2 C_p) \quad (1)$$

where:

P = load, kgf,

A_p = projected area of the indentation, mm^2 ,

d = length of the long diagonal of the indentation, mm,

C_p = $1/2 (\cot A/2 \times \tan B/2)$,

A = included longitudinal edge angle (see Fig. 1), and

B = included transverse edge angle (see Fig. 1).

3.1.1.2 Knoop indentation hardness tests in glass are made at a test load of 100 gf (0.1 kgf).

3.1.1.3 The rate of indenter motion prior to contact with the specimen shall be 0.20 ± 0.05 mm/min. This low rate of load application tends to alleviate the effect of the magnitude of the load on Knoop hardness number.

3.1.1.4 The indenter should remain in contact with the specimen between 20 and 30 s. Most of the calibrated machines that are used for making Knoop hardness tests are dash-pot controlled and this dwell time is consistent with the adjustment of the dash-pot to meet the loading rate standard.

3.1.1.5 Table 1 gives the Knoop hardness of several glasses as a function of load when the loading rate and dwell time are held at the values recommended above.

3.1.2 *Knoop indentation hardness test*—an indentation hardness test using a calibrated machine to force a pointed, rhombic-base, pyramidal diamond indenter having specified face angles, under a predetermined load, into the surface of the material under test and to measure the long diagonal of the resulting impression after removal of the load.

NOTE 1—A general description of the Knoop indentation hardness test is given in Test Method E384. The present method differs from this description only in areas required by the special nature of glasses.

4. Significance and Use

4.1 The Knoop indentation hardness is one of many properties that is used to characterize glasses. Attempts have been made to relate Knoop indentation hardness to tensile strength, grinding speeds, and other hardness scales, but no generally accepted methods are available. Such conversions are limited in scope and should be used with caution, except for special cases where a reliable basis for the conversion has been obtained by comparison tests.

¹ This test method is under the jurisdiction of ASTM Committee C14 on Glass and Glass Products and is the direct responsibility of Subcommittee C14.04 on Physical and Mechanical Properties.

Current edition approved Jan. 1, 2021. Published February 2021. Originally approved in 1972. Last previous edition approved in 2013 as C730 – 98 (2013). DOI: 10.1520/C0730-98R21.

² For referenced ASTM standards, visit the ASTM website, www.astm.org, or contact ASTM Customer Service at service@astm.org. For *Annual Book of ASTM Standards* volume information, refer to the standard's Document Summary page on the ASTM website.

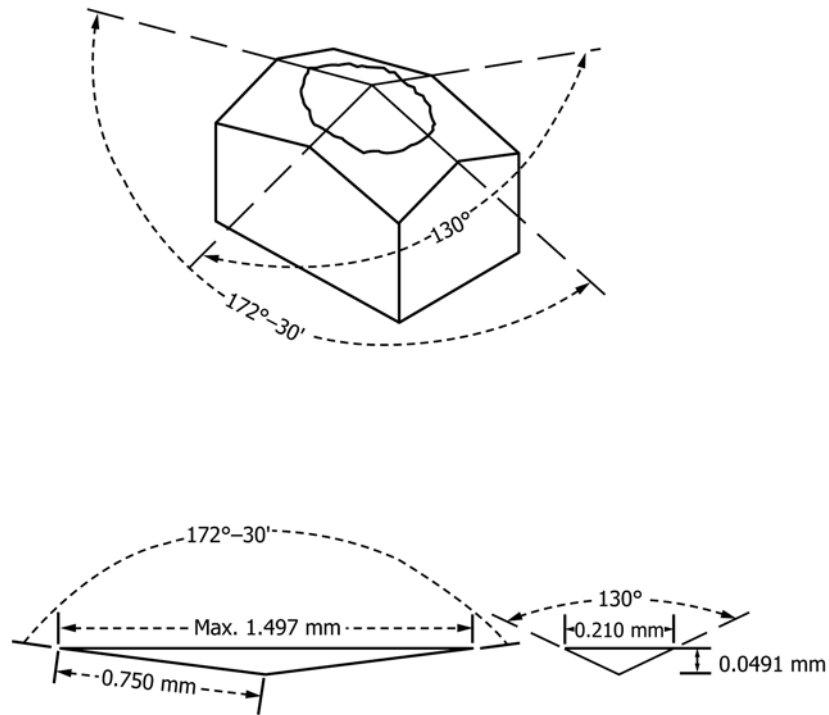

FIG. 1 Knoop Indenter Showing Maximum Usable Dimension

iTeh Standards
(<https://standards.itih.ai>)
Document Preview

TABLE 1 Knoop Hardness of NIST Standard and Other Glasses^{A, B}

Laboratory	NIST 710	NIST 711	GE Fused Quartz				NIST 711	NIST 715	GE Fused Quartz
			NIST 710	NIST 711	NIST 715	GE Fused Quartz			
			25 gf Load				50 gf Load		
A	486	411	589	614	497	394	575	559	
C	594	450			537	415			
D	479	426	505	541	478	380	538	501	
E	521	415	608	620	497	392	574	586	
F	498	414	568	643	484	403	567	577	
G									
Avg	516	423	567.5	609.5	499	397	563.5	556	
Departure, max, %	15	6	11	11	8	5	5	10	
Range, max, %	22	9	18	17	12	9	7	15	
			100 gf Load				200 gf Load		
A	475	387	558	554	468	380	550	523	
C	478	387	554	593	468	371	544	530	
D	452	368	521	473	433	360	529	474	
E	490	396	544	530	488	372	546	510	
F	467	381	538	524	457	367	524	502	
G	481	388	550	558					
Avg	474	384.5	544	539	463	370	539	508	
Departure, max, %	5	4	4	12	6	3	3	7	
Range, max, %	8	7	7	22	12	5	5	11	

^A NIST 710—NIST standard soda-lime-silica glass (no longer available; NIST 710a may be substituted), NIST 711—NIST standard lead-silica glass. NIST 715—NIST standard alkali-free aluminosilicate glass.

^B These data were obtained from ASTM round-robin testing.

5. Apparatus

5.1 Testing Machines:

5.1.1 There are two general types of machines available for making this test. One type is a self-contained unit built for this purpose, and the other type is an accessory available to existing microscopes. Usually, this second type is fitted on an inverted-stage microscope. Good descriptions of the various machines are available.^{3,4}

5.1.2 Design of the machine should be such that the loading rate, dwell time, and applied load can be standardized within the limits set forth in 3.1.1.2 – 3.1.1.4. It is an advantage to eliminate the human element whenever possible by appropriate machine design. The machine should be designed so that vibrations induced at the beginning of a test will be damped out by the time the indenter touches the sample.

5.1.3 The calibration of the balance beam should be checked monthly or as needed. Indentations in standard glasses are also used to check calibration when needed.

5.2 Indenter:

5.2.1 The indenter shall meet the specifications for Knoop indenters.⁴ See Test Method E384.

5.2.2 Fig. 1 shows the indenter and its maximum usable dimensions. The diagonals have an approximate ratio of 7:1, and the depth of the indentation is about $\frac{1}{30}$ the length of the long diagonal. A perfect Knoop indenter has the following angles:

5.2.2.1 Included longitudinal angle $172^{\circ} 30' 00''$.

5.2.2.2 Included transverse angle $130^{\circ} 00' 00''$.

5.2.3 The constant C_p for a perfect indenter is 0.07028 and the specifications require a variation of not more than 1 percent from this value.

5.3 Measuring Microscope—The measurement system shall be so constructed that the length of the diagonals can be determined with errors not exceeding ± 0.0005 mm. The apparent length of the diagonal should be corrected for the limit of resolution of the objective being used in the microscope (see Appendix X1).

6. Test Specimen

6.1 The Knoop indentation hardness test is adaptable to a wide variety of glass specimens, ranging from tubing to television faceplates to polished plate glass. In general, the accuracy of the test will depend on the smoothness of the surface and, whenever possible, ground and polished specimens should be used. The back of the specimen shall be fixed so that the specimen cannot rock or shift during the test.

6.1.1 Thickness—As long as the specimen is over ten times as thick as the indentation depth, this will not affect the test. In general, if specimens are at least 0.10 mm thick, the hardness will not be affected by variations in the thickness.

6.1.2 Surface Finish—As pointed out above, the accuracy of the test depends on the surface finish. However, if one is

investigating a surface coating or treatment, he cannot grind and polish the sample. Experience has shown that six indentations on a ground and polished surface of glass will reproduce within $\pm 1\%$. Six indentations on an “as-received” surface may be as bad as $\pm 10\%$. Ground and polished surfaces should be used. If this is not possible, the number of indentations should be increased.

6.1.3 Radius of Curvature—The KHN obtained will be affected even when the curvature is only in the direction of the short diagonal. Care should be used when relating KHN values obtained on curved surfaces to those obtained on polished flat surfaces.

7. Verification of Apparatus

7.1 Verification of Load—Most of the machines available for Knoop hardness testing use a loaded beam. This beam should be tested for zero load. An indentation should not be visible with zero load, but the indenter should contact the sample. A visible indentation should be obtained with a load of 0.1 gf. Other methods of verifying the load application are given in Practices E4.

7.2 Verification by Standard Glasses—Table 1 gives the Knoop hardness of several standard glasses. Knoop hardness measurement on a piece of one of these glasses that has been ground and polished within the last 24 h should agree with the value in the table $\pm 5\%$. Tests should be made using 100 gf.

8. Procedure

8.1 Specimen Placement—Place the specimen on the stage of the machine in such a way so that the specimen will not be able to rock or shift during the measurement.

8.2 Specimen Leveling:

8.2.1 The surface of the specimen being tested must lie in a plane normal to the axis of the indenter. Fig. 2 shows an indentation as it will appear through the microscope with five points labeled. To level the specimen, make a test indentation using a 100 gf load.

8.2.2 The following minimum specifications must be met:

$$OA = OB \pm 5\%$$

$$OC = OD \pm 5\%$$

8.2.3 Leveling the specimen to meet these specifications is facilitated if one has a leveling device.

8.3 Magnitude of Test Load—A test load of 100 gf is specified. If cracks develop at this load, measurements within 50 or 25 gf loads may be made although the Knoop indentation hardness does vary with load. Table 1 gives an indication of the magnitude of this variation to be expected. In all cases, the load actually used should be reported.

8.4 Application of Test Load:

8.4.1 Start the machine smoothly. If the machine is loaded by an electrical system or a dash-pot lever system, it should be mounted on shock absorbers which damp out all vibrations by the time the indenter touches the specimen. If the specimen is hand-loaded, take extreme care to see that the loading rate never goes higher than 0.25 mm/min.

³ Specifications for Knoop indenters can be found in the book Small, L., *Hardness Theory and Practice* (Part I: Practice), Service Diamond Tool Co., Ann Arbor, MI, 1960, pp. 241–243.

⁴ Mott, B. W., *Micro-Indentation Hardness Testing*, Butterworth's Scientific Publications, London, 1956.