



Designation: ~~C133 – 97 (Reapproved 2015)~~ C133 – 97 (Reapproved 2021)

Standard Test Methods for Cold Crushing Strength and Modulus of Rupture of Refractories¹

This standard is issued under the fixed designation C133; the number immediately following the designation indicates the year of original adoption or, in the case of revision, the year of last revision. A number in parentheses indicates the year of last reapproval. A superscript epsilon (ϵ) indicates an editorial change since the last revision or reapproval.

This standard has been approved for use by agencies of the U.S. Department of Defense.

1. Scope

1.1 These test methods cover the determination of the cold crushing strength and the modulus of rupture (MOR) of dried or fired refractory shapes of all types.

1.2 The test methods appear in the following sections:

Test Method	Sections
Cold Crushing Strength	4 to 9
Modulus of Rupture	10 to 15

1.3 The values stated in inch-pound units are to be regarded as standard. The values given in parentheses are mathematical conversions to SI units that are provided for information only and are not considered standard.

1.4 *This standard does not purport to address all of the safety concerns, if any, associated with its use. It is the responsibility of the user of this standard to establish appropriate safety, health, and environmental practices and determine the applicability of regulatory limitations prior to use.*

1.5 *This international standard was developed in accordance with internationally recognized principles on standardization established in the Decision on Principles for the Development of International Standards, Guides and Recommendations issued by the World Trade Organization Technical Barriers to Trade (TBT) Committee.*

2. Referenced Documents

2.1 ASTM Standards:²

[C862 Practice for Preparing Refractory Concrete Specimens by Casting](#)

[C1054 Practice for Pressing and Drying Refractory Plastic and Ramming Mix Specimens](#)

[E4 Practices for Force Verification of Testing Machines](#)

3. Significance and Use

3.1 The cold strength of a refractory material is an indication of its suitability for use in refractory construction. (It is not a measure of performance at elevated temperatures.)

¹ These test methods are under the jurisdiction of ASTM Committee C08 on Refractories and are the direct responsibility of Subcommittee C08.01 on Strength. Current edition approved March 1, 2015; Feb. 1, 2021. Published May 2015; February 2021. Originally approved in 1937. Last previous edition approved in 2008 as C133 – 97 (2008) (2015). DOI: 10.1520/C0133-97R15-10.1520/C0133-97R21.

² For referenced ASTM standards, visit the ASTM website, www.astm.org, or contact ASTM Customer Service at service@astm.org. For Annual Book of ASTM Standards volume information, refer to the standard's Document Summary page on the ASTM website.

3.2 These test methods are for determining the room temperature flexural strength in ~~3-point~~three-point bending (cold modulus of rupture) or compressive strength (cold crushing strength), or both, for all refractory products.

3.3 Considerable care must be used to compare the results of different determinations of the cold crushing strength or modulus of rupture. The specimen size and shape, the nature of the specimen faces (that is, as-formed, sawed, or ground), the orientation of those faces during testing, the loading geometry, and the rate of load ~~application~~application may all significantly affect the numerical results obtained. Comparisons of the results between different determinations should not be made if one or more of these parameters differ between the two determinations.

3.4 The relative ratio of the largest grain size to the smallest specimen dimension may significantly affect the numerical results. For example, ~~smaller~~smaller cut specimens containing large grains may present different results than the bricks from which they were cut. Under no circumstances should ~~6-6~~ by ~~4-1~~ by 1-in. (~~152-~~152 by ~~25-25~~ by 25-mm) specimens be prepared and tested for materials containing grains with a maximum grain dimension exceeding 0.25 in. (6.4 mm).

3.5 This test method is useful for research and development, engineering application and design, manufacturing process control, and for developing purchasing specifications.

COLD CRUSHING STRENGTH

4. Apparatus

4.1 *Testing Machine*—Any form of standard mechanical or hydraulic compression testing machine conforming to the requirements of Practices E4 may be used.

NOTE 1—For low-strength materials (such as insulating bricks or castables), a sensitivity of 20 lbf (67 kN) or less is required. The use of a hydraulic testing machine is also preferred over the mechanical type for these materials.

4.2 *Spherical Bearing Block*—The plane surface of the spherical bearing block (see Fig. 1) shall have an area which is equal to or greater than the cross section of the test specimen.

5. Test Specimens

5.1 *Brick and Shapes (bulk density greater than 100 lb/ft³ (1.60 g/cm³))*—The test specimens shall be 2-in. (51-mm) cubes or cylinders, 2 in. (51 mm) in diameter by 2 in. (51 mm) high. The height should be parallel to the original direction of pressing of the brick or shape. In the case of special shapes, only one specimen shall be cut from a single shape and as many of the original surfaces as possible shall be preserved. In preparing specimens from irregular or large refractory shapes, any method involving the

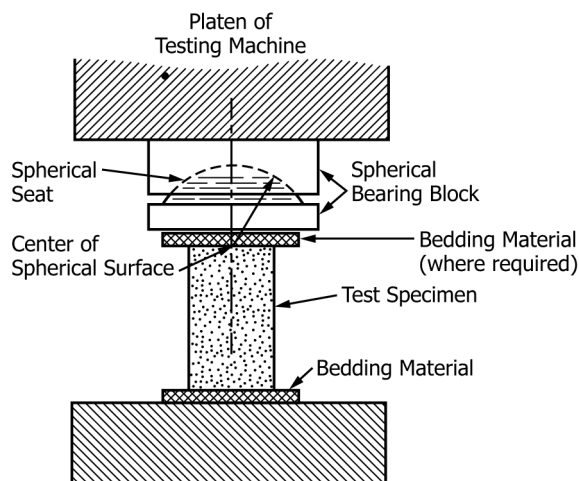

FIG. 1 Recommended Design for Crushing Test Assembly, Including Bearing Block

use of abrasives, such as a high-speed abrasion wheel, core drill, or rubbing bed, that will produce a specimen with approximately plane and parallel sides without weakening the structure of the specimen may be used.

5.2 *Insulating Brick or Shapes* (typical bulk density of 100 lb/ft³ (1.60 g/cm³), or greater than 45 % total porosity, or both)—The test specimens shall be 4½ by 4½ by 2½ or 3 in. (114 by 114 by 64 or 76 mm), each taken from a different brick. It is permissible to prepare these specimens from the half-brick resulting from the modulus of rupture test (see Sections 9 – 14). The selected compression test section shall be free of cracks, chipped surfaces, and other obvious defects. The test surfaces shall be approximately parallel planes.

5.3 *Castable Refractories*—The test specimens shall be 2-2 by 2-2 by 2-in. (~~51-(51~~ by ~~51-51~~ by 51-mm) cubes or cylinders 2 in. (~~51-mm~~)-(51 mm) in diameter by 2 in. (51 mm) high, prepared by casting or gunning. It is permissible to prepare one specimen from each 9-9 by 2-2 by 2-in. (~~230-(230~~ by ~~51-51~~ by 51-mm) bar after the modulus of rupture test (see Sections 9 – 14). The selected compression test section shall be free of cracks, chipped surfaces, and other obvious defects. The loaded surfaces shall be approximately parallel planes. All samples must be dried at 220 to ~~230°F~~230 °F (105 to ~~110°C~~)110 °C for 18 h (overnight). Upon removal from the oven, allow the sample to cool naturally until cool to the touch. Complete testing within 2 h of removal from the drying oven. (See Practices C862 and C1054.)

6. Procedure

6.1 At least five specimens from an equivalent number of refractory shapes compose a sample.

NOTE 2—For relatively weak specimens like insulating castables or insulating firebricks, a minimum sample size of ten specimens is preferred.

6.2 *Brick and Shapes*—Place a cellulose fiber wall board (for example, Masonite³) 0.25 in. (6.4 mm) in thickness and extending 0.5 in. (12.7 mm) or more beyond the edges of the loaded faces of the specimen. Apply the load parallel to the direction in which the brick was originally pressed.

6.3 *Regular and High-Strength High-Strength Castables*—Place a cellulose fiber wall board 0.25 in. (6.4 mm) in thickness and extending 0.5 in. (12.7 mm) or more beyond the edges of the loaded faces of the specimen. Apply the load on the 2-2 by 2-in. (~~51-(51~~ by 51-mm) or 2-in. (51-mm) diameter face and perpendicular to the depth of the specimen as originally cast or gunned.

6.4 *Insulating Brick or Shapes*—Apply the load directly to the 4½- by 4½-in. (~~114-(114~~ by 114-mm) surface of the test specimen.

6.5 *Insulating Castables* (typical bulk density of 100 lb/ft³ (1.60 g/cm³), or greater than 45 % total porosity, or both)—Apply the load directly to the 2-2 by 2-in. (~~51-(51~~ by 51-mm) face and perpendicular to the depth of the specimen as originally cast or gunned.

6.6 Use the bearing block on top of the test specimen, and position it so that the center of the sphere is in alignment with the vertical axis of the specimen (see Fig. 1). Keep the spherical bearing block thoroughly lubricated to ensure accurate adjustment which may be made by hand under a small initial load for each specimen.

NOTE 3—The spherical bearing block may not be necessary on test machines having mechanical linkages which ensure that the stress applied is colinear with the axis of the specimen.

6.7 For *dense* refractories with sufficient strength to require greater than about 3 min per test, initial loading to ~~one-half~~ one half of the anticipated failure load may be accomplished at any convenient rate exceeding the specified rate. Subsequently, each specimen shall be crushed with a compressive load applied at the standard rates specified in Table 1. The rates shall not vary by more than ±10 % of the specified rate for the type of refractory being tested.

6.8 When using a mechanical testing machine, keep the balance beam in a constantly floating position.

6.9 Specimens are loaded, as specified, to failure. Failure is defined as the collapse of the specimen (failure to support the load), or the reduction of the specimen height to 90 % of its original value. The maximum applied load is recorded.

³ Masonite has been found satisfactory for this purpose.

TABLE 1 Standard Loading Rates for Cold Crushing Strength

Refractory Type	Size, in. (mm)	Loaded Cross Section, in. (mm)	Loaded Area, in. ² (mm ²)	Stress Rate, lbf/in. ² /min (MPa/min)	Loading Rate, lbf/min (kN/min)	Strain Rate, ⁴ in./min (mm/min)
<i>Refractory Brick and Shapes</i>						
Density >100 lb/ft ³ (>1.60 gm/cm ³), or <45 % true porosity, or both	2 × 2 × 2 (51 × 51 × 51)	2 × 2 (51 × 51)	4 (2601)	1750 ^B (12)	7000 ^B (31.2)	0.05 ^B (1.3)
(Includes regular or high-strength castables and fired plastic or rammed refractories)	2 diameter × 2 (51 diameter × 51)	2, diameter (51, diameter)	3.14 (2027)	1750 ^B (12)	5500 ^B (24.3)	0.05 ^B (1.3)
(Includes regular or high-strength castables and fired plastic or rammed refractories)	2 diameter × 2 (51 diameter × 51)	2, diameter (51, diameter)	3.14 (2027)	1750 ^B (12)	5500 ^B (24.3)	0.05 ^B (1.3)
<i>Insulating Refractories</i>						
Density <100 lb/ft ³ (<1.60 gm/cm ³), or >45 % true porosity, or both	4.5 × 4.5 × 2.5 ^{C,D} (114 × 114 × 64)	4.5 × 4.5 (114 × 114)	20.25 (13 064)	435 (3)	8809 (39)	0.05 (1.3)
(Includes dried, unfired plastic or rammed refractories)	4.5 × 4.5 × 3 ^{C,D} (114 × 114 × 76)	4.5 × 4.5 (114 × 114)	20.25 (13 064)	435 (3)	8809 (39)	0.05 (1.3)
	2 × 2 × 2 ^{D,E} (51 × 51 × 51)	2 × 2 (51 × 51)	4 (2601)	435 (3)	1740 (7.80)	0.05 (1.3)
	2 diameter × 2 ^E (51 diameter × 51)	2, diameter (51, diameter)	3.14 (2027)	435 (3)	1367 (6.08)	0.05 (1.3)

^A Where possible, loading at a constant stress rate is preferable to constant strain rate loading.

^B For *dense* refractory brick and shapes requiring more than a 3-min test duration, specimens may be loaded to one half of the anticipated fracture strength at any convenient rate exceeding that specified.

^C These sizes are preferred for insulating firebricks.

^D These pieces may be cut from broken halves of MOR specimens.

^E These sizes are preferred for insulating castables.

7. Calculation

7.1 Calculate the cold crushing strength using Eq 1:

$$S = W/A \quad (1)$$

where:

S = cold crushing strength, lbf/in.² (MPa),

W = total maximum load indicated by the testing machine, lbf (N), and

A = average of the areas of the top and bottom of the specimen perpendicular to the line of application of the load, in.² (mm²).

8. Report

8.1 Report the following:

8.1.1 Designation of the materials tested (that is, manufacturer, brand, description, lot number, etc.);

8.1.2 Specimen configuration, including size, shape, location in the original brick or shape, the character of the faces (that is, cut, drilled, as-pressed, as-cast, etc.), and the specimen orientation during testing;

8.1.3 Pretreatment, if any, given to the test pieces (for example, curing, firing, coking, etc.);

8.1.4 Number of specimens in a sample;

8.1.5 Individual specimen dimensions, the maximum applied load, and the calculated cold crushing strength for each specimen (see 7.1);

8.1.6 Mean cold crushing strength and standard deviation for each sample.

MODULUS OF RUPTURE

9. Apparatus

9.1 *Testing Machine*—Any form of standard mechanical or hydraulic compression testing machine conforming to the requirements of Practices E4 may be used.