



Designation: F1504 – 14 (Reapproved 2021)

# Standard Specification for Folded Poly(Vinyl Chloride) (PVC) Pipe for Existing Sewer and Conduit Rehabilitation<sup>1</sup>

This standard is issued under the fixed designation F1504; the number immediately following the designation indicates the year of original adoption or, in the case of revision, the year of last revision. A number in parentheses indicates the year of last reapproval. A superscript epsilon ( $\epsilon$ ) indicates an editorial change since the last revision or reapproval.

## 1. Scope\*

1.1 This specification covers requirements and test methods for materials, dimensions, workmanship, flattening resistance, impact resistance, pipe stiffness, extrusion quality, and a form of marking for folded (vinyl chloride) (PVC) pipe for existing sewer and conduit rehabilitation.

1.2 Pipe produced to this specification is for use in non-pressure sewer and conduit rehabilitation where the folded PVC pipe is inserted into and then expanded to conform to the wall of the original conduit forming a new structural pipe-within-a-pipe.

NOTE 1—For installation procedures refer to Practice F1947.

1.3 This specification includes pipe made only from materials specified in Section 6. This specification does not include pipe manufactured from reprocessed, recycled, or reclaimed PVC.

1.4 The values stated in inch-pound units are to be regarded as standard. The values given in parentheses are mathematical conversions to SI units that are provided for information only and are not considered standard.

1.5 The following precautionary statement pertains to the test method portion only, Section 11, of this specification: *This standard does not purport to address all of the safety concerns, if any, associated with its use. It is the responsibility of the user of this standard to establish appropriate safety, health, and environmental practices and determine the applicability of regulatory limitations prior to use.*

1.6 *This international standard was developed in accordance with internationally recognized principles on standardization established in the Decision on Principles for the Development of International Standards, Guides and Recommendations issued by the World Trade Organization Technical Barriers to Trade (TBT) Committee.*

<sup>1</sup> This specification is under the jurisdiction of ASTM Committee F17 on Plastic Piping Systems and is the direct responsibility of Subcommittee F17.67 on Trenchless Plastic Pipeline Technology.

Current edition approved Feb. 15, 2021. Published February 2021. Originally approved in 1994. Last previous edition approved in 2014 as F1504–14. DOI: 10.1520/F1504-14R21.

## 2. Referenced Documents

### 2.1 ASTM Standards:<sup>2</sup>

- D618 Practice for Conditioning Plastics for Testing
- D790 Test Methods for Flexural Properties of Unreinforced and Reinforced Plastics and Electrical Insulating Materials
- D1600 Terminology for Abbreviated Terms Relating to Plastics
- D1784 Classification System and Basis for Specification for Rigid Poly(Vinyl Chloride) (PVC) Compounds and Chlorinated Poly(Vinyl Chloride) (CPVC) Compounds
- F1947 Practice for Installation of Folded Poly (Vinyl Chloride) (PVC) Pipe into Existing Sewers and Conduits (Withdrawn 2019)<sup>3</sup>
- D2122 Test Method for Determining Dimensions of Thermoplastic Pipe and Fittings
- D2152 Test Method for Adequacy of Fusion of Extruded Poly(Vinyl Chloride) (PVC) Pipe and Molded Fittings by Acetone Immersion
- D2412 Test Method for Determination of External Loading Characteristics of Plastic Pipe by Parallel-Plate Loading
- D2444 Practice for Determination of the Impact Resistance of Thermoplastic Pipe and Fittings by Means of a Tup (Falling Weight)
- F412 Terminology Relating to Plastic Piping Systems
- F1057 Practice for Estimating the Quality of Extruded Poly (Vinyl Chloride) (PVC) Pipe by the Heat Reversion Technique

### 2.2 Federal Standard:<sup>4</sup>

- Fed. Std. No. 123 Marking for Shipment (Civil Agencies)

### 2.3 Military Standard:<sup>4</sup>

- MIL-STD-129 Marking for Shipment and Storage

<sup>2</sup> For referenced ASTM standards, visit the ASTM website, [www.astm.org](http://www.astm.org), or contact ASTM Customer Service at [service@astm.org](mailto:service@astm.org). For *Annual Book of ASTM Standards* volume information, refer to the standard's Document Summary page on the ASTM website.

<sup>3</sup> The last approved version of this historical standard is referenced on [www.astm.org](http://www.astm.org).

<sup>4</sup> Available from DLA Document Services Building 4/D 700 Robbins Avenue Philadelphia, PA 19111-5094 <http://quicksearch.dla.mil/>

\*A Summary of Changes section appears at the end of this standard

3. Terminology

3.1 *General*—Abbreviations used in this specification are in accordance with Terminology D1600 and definitions are in accordance with Terminology F412 unless otherwise indicated.

3.2 *Definitions of Terms Specific to This Standard:*

3.2.1 *folded pipe*—pipe that has been manufactured in a folded shape or that is subsequently folded for use in existing sewer and conduit rehabilitation. See Fig. 1.

3.2.2 *rounded pipe*—A rounded pipe is a sample for test purposes formed when the folded pipe has been inserted into a circular casing pipe and expanded with heat and pressure to fit tightly to the casing pipe taking a circular cross section, in accordance with Section 10. See Fig. 1.

4. Significance and Use

4.1 The requirements of this specification are intended to provide folded pipe suitable for the rehabilitation of existing pipelines and conduits conveying sewage, process flow, and storm water, under non-pressure conditions, through the heating, insertion, and expansion of the folded pipe.

NOTE 2—Industrial waste disposal lines should be installed only with the specific approval of the cognizant code authority since chemicals not commonly found in drains and sewers and temperatures in excess of 140 °F (60 °C) may be encountered.

5. Application of Materials

5.1 The nominal folded PVC pipe sizes specified in Section 8 are applicable for a range of original pipe inside diameters. Table 1 lists the recommended ranges for each nominal size.

6. Materials and Manufacture

6.1 *Basic Materials*—The pipe shall be made from virgin PVC compound meeting all the requirements for cell classifications 12334, 13223, 32334, or 33223 as defined in Specification D1784.

6.2 *Rework Material*—Clean rework material, generated from the manufacturer’s own PVC sewer pipe production may be used by the same manufacturer provided that the rework material meets the requirements of 6.1 and that the pipe produced meets all the requirements of this specification. Reworked material of intermixed cell classifications shall be

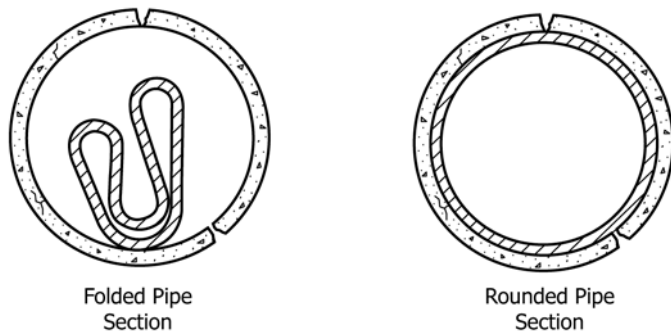

NOTE 1—This figure is intended only for clarification of terms specific to this specification and shows a representative folded pipe shape. Other folded pipe shapes may meet the requirements of this specification.

FIG. 1 Folded Pipe and Rounded Pipe—Clarification of Terms

TABLE 1 Folded PVC Pipe, Recommended Size Ranges of Use

NOTE 1—The minimum and maximum recommended existing pipe inside diameters shown in Table 1 are mean inside diameters along the pipe length and are not intended as absolute limits on localized dimensions. Consult the manufacturer for use of folded PVC pipe for sizes of existing pipe beyond the recommended ranges shown in Table 1.

Folded Pipe Nominal Outside Diameter, in. (mm)	Recommended Existing Pipe Inside Diameter Range, in. (mm)		Resulting DR over Diameter Range		
	min	max	DR 50	DR 41	DR 35
4 (102)	3.7 (94)	4.2 (107)	...	...	32–40
6 (152)	5.6 (142)	6.3 (160)	...	38–46	32–40
8 (203)	7.4 (188)	8.4 (213)	47–55	38–46	32–40
9 (229)	8.3 (211)	9.4 (239)	47–55	38–46	32–40
10 (254)	9.3 (236)	10.5 (267)	47–55	38–46	32–40
12 (305)	11.3 (287)	12.8 (325)	47–55	38–46	32–40
15 (381)	13.9 (353)	15.7 (399)	47–55	38–46	32–40

labeled as the minimum cell classification of this specification, and labeled in accordance with 15.1.3.1. Reworked material containing any copolymer materials shall be labeled as copolymer material.

7. Other Requirements

7.1 *Pipe Flattening*—There shall be no evidence of splitting, cracking, or breaking when the rounded pipe is tested in accordance with 11.3.

7.2 *Pipe Impact Strength*—The impact strength of the rounded pipe shall not be less than the values given in Table 2 when tested in accordance with 11.4.

NOTE 3—This test is intended only for use as a quality-control test, not as a simulated service test.

7.3 *Pipe Stiffness*—Pipe stiffness values for the rounded pipe shall comply with Table 3 when tested in accordance with 11.6.

7.4 *Extrusion Quality*—The extrusion quality of the pipe shall be evaluated by both of the following test methods.

7.4.1 *Acetone Immersion*—The pipe shall not flake or disintegrate when tested in accordance with 11.6.1.

7.4.2 *Heat Reversion*—The extrusion quality shall be estimated by heat reversion method in accordance with 11.6.2.

7.5 *Flexural Properties*—Flexural modulus of elasticity values for the rounded pipe shall comply with Table 4 when tested in accordance with 11.7.

TABLE 2 Minimum Impact Strength at 73 °F (23 °C)

Pipe Size, in. (mm)	Impact Strength, ft-lbf (J)
4 (102)	150 (203)
6 (152)	210 (284)
8 (203)	210 (284)
9 (229)	220 (299)
10 (254)	220 (299)
12 (305)	220 (299)
15 (381)	220 (299)

**TABLE 3 Minimum Pipe Stiffness at 5 % Deflection**

NOTE 1—Higher stiffness, due to higher moduli or lower DR, may also be available; consult the manufacturer.

Pipe Size, in. (mm)	Pipe Stiffness, psi (kPa)					
	PS-1 <sup>A</sup>			PS-2 <sup>B</sup>		
	DR 50	DR 41	DR 35	DR 50	DR 41	DR 35
4 (102)	...	...	31 (219)	...	...	36 (250)
6 (152)	...	19 (134)	31 (219)	...	22 (153)	36 (250)
8 to 15 (203 to 381)	10 (73)	19 (134)	31 (219)	12 (83)	22 (153)	36 (250)

<sup>A</sup> PS-1 is for material with a minimum cell classification of 13223 or 33223 (280 000-psi (1.93 Gpa) minimum modulus).

<sup>B</sup> PS-2 is for material with a minimum cell classification of 12334 or 32334 (320 000-psi (2.21 Gpa) minimum modulus).

**TABLE 4 Rounded Pipe Flexural Properties**

Cell Classification	Flexural Modulus, psi (GPa)
13223, 33223	280 000 (1.93)
12334, 32334	320 000 (2.21)

## 8. Dimensions, Mass, and Permissible Variations

8.1 *Rounded Pipe Diameter*—The average outside diameter of the rounded pipe shall meet the requirements given in [Table 5](#) with a tolerance of  $\pm 1.0\%$  when measured in accordance with [11.2.1](#).

8.2 *Rounded Pipe Wall Thickness*—The minimum wall thickness of the rounded pipe, when measured in accordance with [11.2.2](#), shall not be less than the values specified in [Table 5](#).

## 9. Workmanship, Finish, and Appearance

9.1 The rounded and folded pipes shall be homogeneous throughout and free from visible cracks, holes, foreign inclusions, or other injurious defects. The pipe shall be as uniform as commercially practical in color, opacity, density, and other physical properties.

## 10. Sampling

10.1 Rounded pipe sample preparation shall involve the unfolding and expansion of a folded pipe sample within a split pipe mold with an inside diameter equal to the nominal outside diameter shown in [Table 2](#). A folded pipe sample of sufficient length (10 ft (3 m) maximum) to complete the testing requirements shall be inserted into the split pipe mold and secured at the ends. The assembly shall then be placed in an enclosed chamber for heating. Ambient pressure steam shall be applied to the chamber for at least a 15-min period at a minimum temperature of 200 °F (93 °C). While maintaining the minimum 200 °F (93 °C) temperature, the folded pipe shall then be rounded by applying internal steam pressure at 8 psig (55 kPa)

**TABLE 5 Rounded Pipe Dimensions**

Outside Diameter, in. (mm)	Minimum Wall Thickness, in. (mm)		
	DR 50	DR 41	DR 35
4.000 (101.6)	...	...	0.114 (2.9)
6.000 (152.4)	...	0.146 (3.7)	0.171 (4.3)
8.000 (203.2)	0.160 (4.1)	0.195 (5.0)	0.229 (5.8)
9.000 (228.6)	0.180 (4.6)	0.219 (5.6)	0.257 (6.5)
10.000 (254.0)	0.200 (5.1)	0.243 (6.2)	0.286 (7.3)
12.000 (304.8)	0.240 (6.1)	0.292 (7.4)	0.343 (8.7)
15.000 (381.0)	0.300 (7.6)	0.365 (9.3)	0.429 (10.9)

for a period of 2 min. While maintaining the 8-psig internal pressure, transition to air pressure and cool the sample to 100 °F (38 °C) or less. Remove the rounded sample from the mold for testing.

10.2 The frequency of sampling shall be as agreed upon between the purchaser and the seller.

10.3 Initial and retest samples shall be drawn from the same production shift.

## 11. Test Methods

11.1 *Test Conditions*—Conduct tests in the standard laboratory atmosphere of 73.4 °F  $\pm$  3.6°F (23 °C  $\pm$  2 °C) and 50  $\pm$  5 % relative humidity, with test specimens conditioned in accordance with Procedure A of Practice [D618](#), unless otherwise specified in the test methods or in this specification.

### 11.2 Rounded Pipe Dimensions:

11.2.1 *Pipe Diameters*—Measure the outside diameter of the pipe in accordance with the applicable section of Test Method [D2122](#). Either a tapered sleeve gage or a vernier circumferential wrap tape accurate to  $\pm 0.001$  in. ( $\pm 0.02$  mm) may be used.

11.2.2 *Wall Thickness*—Measure the wall thickness in accordance with the applicable sections of Test Method [D2122](#). Make sufficient readings, a minimum of six, to ensure that the minimum thickness has been determined. Use a cylindrical anvil tubing micrometer accurate to  $\pm 0.001$  in. ( $\pm 0.02$  mm).

11.3 *Pipe Flattening*—Flatten three specimens of rounded pipe, 6-in. (150-mm) long, between parallel plates in a suitable press until the distance between the plates is 40 % of the outside diameter of the pipe. The rate of loading shall be uniform and such that the compression is completed within 2 to 5 min. Remove the load and examine the specimens for evidence of splitting, cracking, or breaking.

11.4 *Impact Resistance*—Determine the impact resistance of the rounded pipe in accordance with the applicable section of Test Method [D2444](#), using a 20-lb (9-kg) Tup A and the flat plate Holder B. Test six specimens each 6 in. (150 mm) long at the impact levels given in [Table 2](#). All shall pass. If one fails, test another six specimens; eleven passes out of twelve tested shall be acceptable.

11.5 *Pipe Stiffness*—Determine the pipe stiffness for rounded pipe specimens using Test Method [D2412](#). Test three specimens, each 6 in. (150 mm) long. The pipe stiffness of each specimen at 5 % deflection shall equal or exceed the minimum value listed in [Table 3](#).