



Designation: C1460 – 21

# Standard Specification for Shielded Transition Couplings for Use with Dissimilar DWV Pipe and Fittings Above Ground<sup>1</sup>

This standard is issued under the fixed designation C1460; the number immediately following the designation indicates the year of original adoption or, in the case of revision, the year of last revision. A number in parentheses indicates the year of last reapproval. A superscript epsilon ( $\epsilon$ ) indicates an editorial change since the last revision or reapproval.

## 1. Scope

1.1 This specification covers the performance of shielded transition couplings to join dissimilar DWV pipe and fittings above ground up to and including 15-in. pipe and fittings. This standard is intended to cover reducing couplings used to join pipes and fittings of different sizes, materials, and different outside diameters.

1.2 The values stated in inch-pound units are to be regarded as standard. The values given in parentheses are mathematical conversions to SI units that are provided for information only and are not considered standard.

1.3 The committee with jurisdiction over this standard is not aware of any comparable standards published by other organizations.

1.4 The following precaution comment pertains only to the test method portion, Section 7, of this specification. *This standard does not purport to address all of the safety concerns, if any, associated with its use. It is the responsibility of the user of this standard to establish appropriate safety, health, and environmental practices and determine the applicability of regulatory limitations prior to use.*

1.5 *This international standard was developed in accordance with internationally recognized principles on standardization established in the Decision on Principles for the Development of International Standards, Guides and Recommendations issued by the World Trade Organization Technical Barriers to Trade (TBT) Committee.*

## 2. Referenced Documents

2.1 *ASTM Standards:*<sup>2</sup>

[A493 Specification for Stainless Steel Wire and Wire Rods for Cold Heading and Cold Forging](#)

<sup>1</sup> This specification is under the jurisdiction of ASTM Committee A04 on Iron Castings and is the direct responsibility of Subcommittee A04.75 on Gaskets and Coupling for Plumbing and Sewer Piping.

Current edition approved March 1, 2021. Published March 2021. Originally approved in 2000. Last previous edition approved in 2020 as C1460 – 20. DOI: 10.1520/C1460-21.

<sup>2</sup> For referenced ASTM standards, visit the ASTM website, [www.astm.org](http://www.astm.org), or contact ASTM Customer Service at [service@astm.org](mailto:service@astm.org). For *Annual Book of ASTM Standards* volume information, refer to the standard's Document Summary page on the ASTM website.

[A644 Terminology Relating to Iron Castings](#)

[C564 Specification for Rubber Gaskets for Cast Iron Soil Pipe and Fittings](#)

## 3. Terminology

3.1 *Definitions*—The following definitions used in this specification are found in Terminology [A644](#): *elastomeric*, *thermoset*, and *thermoplastic*.

3.2 *Definitions of Terms Specific to This Standard:*

3.2.1 *center stop, n*—an integral part of the gasket centered on the axial length of the gasket intended to limit the insertion depth of the pipe to be coupled.

3.2.2 *clamp assembly, n*—that portion of the coupling excluding the gasket.

3.2.3 *coupling, n*—the complete assembly.

3.2.4 *dissimilar DWV pipe and fittings, n*—pipe and fittings made of different materials or different outside diameters, or both.

3.2.5 *fitting, n*—parts of a pipeline other than straight pipes, valves, or couplings.

3.2.6 *gasket, n*—the elastomeric portion of the coupling.

3.2.7 *joint, n*—the point of assembly consisting of the coupling and the joined pipes or fittings, or both.

3.2.8 *shield, n*—an external metallic protective device designed to protect the sealing gasket from external elements that could cause failure of the sealing assembly.

## 4. Materials and Manufacture

4.1 Physical properties of gaskets shall be in accordance with Table 1 of Specification [C564](#), using the durometer hardness column as specified by the manufacturer.

4.2 All steel parts made from round stock shall be 300 series stainless steel and shall conform to the requirements of Specification [A493](#) (excluding copper-bearing alloys).

## 5. Elastomeric Gasket Requirements

5.1 The elastomeric gasket shall consist of one piece in accordance with the physical requirements of [4.1](#).

5.1.1 The elastomeric gasket shall have an inside center stop-ring spaced equal distance from the ends to serve as a stop

between the pipe/fitting ends that does not create an enlargement chamber or recess with a ledge, shoulder, or reduction of pipe area or offer an obstruction to flow. A gasket without an inside center stop shall be permitted where telescoping of the piping is necessary.

5.1.2 The elastomeric gasket shall be free of defects that affect the use and performance.

**6. Clamp Assembly Requirements**

6.1 Clamp assemblies shall be tested to withstand no less than 125 % of the manufacturer-stated installation torque, 60 lb/in. minimum (6.78 N-m) of applied torque, whichever is greater, without visible signs of failure. The clamp assembly shall be tested over a steel mandrel sized within the range of the clamp and torqued as required.

6.2 Clamp assembly screws or bolts shall not have screw-driver slots.

**7. Coupling Requirements and Test Methods**

7.1 Assemble each coupling tested in accordance with the manufacturer’s instructions between two sections of randomly selected pipe not to exceed 20 ft in length manufactured to appropriate standards for the type of pipe the couplings are expected to join, and conduct the following tests:

7.1.1 *Deflection Test*—Mount each coupling tested between two pieces of pipe as provided in 7.1. Close the outbound ends of the pipe with test plugs. Fill the assembly with water, expel all air, and hydrostatically pressurize to 4.3 psi for the duration of the test. Rigidly support one pipe while the assembly is under pressure, raise the opposite end of the other pipe one half inch per lineal foot of pipe. Maintain the pressure for 5 min and do not permit leakage. A test apparatus such as the one shown in Fig. 1 is suggested.

7.1.2 *Shear Test*—Fill the assembly with water, expel all air, and hydrostatically pressurize to 4.3 psi for the duration of the test. Support two joined lengths of pipe selected in accordance with 7.1 on blocks at three locations. Support one length on blocks, one near the uncoupled end, and the other immediately adjacent to the couplings. Firmly restrain this length in position (see Fig. 2). The other coupled length shall be a minimum of 5 ft (1.52 m) in length and supported by a single block 6 in. (152.4 mm) from the end of the pipe. Apply a load of 50 lb/in. of nominal diameter at a point 6 in. from the edge of the coupling upon a 12-in. length of (3 by 3) angle iron or load distributing pad located on the top of the pipe immediately

adjacent to the coupling of the pipe having one support only. When testing reducing couplings, apply the load to the reduced size. Under this loading there shall be no visible leakage displacement of more than 3/8 in. from true alignment when an internal pressure equivalent to a 10-ft head of water (4.3 psi) is applied. Maintain the load and internal pressure 15 min and do not permit leakage.

*7.2 Unrestrained Hydrostatic Joint Test:*

7.2.1 Each coupling tested shall be assembled in accordance with the manufacturer’s instructions between two sections of machined steel pipe and conduct the unrestrained hydrostatic joint test.

7.2.2 The plain ends of the pipe to be used shall be machined to the correct nominal outside diameter of the types of pipe for which the coupling is intended to join. Plain ends shall have 0.015-in. (2-mm) deep grooves machined circumferentially around them at 0.125-in. (3.2-mm) intervals down the pipe section for a distance equal to that covered by the elastomeric sleeve. The tool used to machine the grooves shall have a 60° included angle and shall cut into the pipe from a perpendicular position. The surface between the grooves shall be a lathe-turned surface of 125 RMS. The plain ends of the pipe are to be uncoated and shall be cleaned with acetone and thoroughly dried before each assembly.

7.2.3 Fill the pipe assembly with water, expelling all air, and increase the hydrostatic pressure at a rate of 1 psi (6.9 kPa) every 30 s until the target test pressure is reached. The target test pressure shall be 20 psi (138 kPa) for 1½ through 5-in. pipe, 18 psi (124 kPa) for 6-in. pipe, 10 psi (69 kPa) for 8-in. pipe, 6 psi (41.4 kPa) for 10-in. pipe, and 6 psi (41.4 kPa) for 12-in. (305-mm) and 15-in. (380-mm) pipe. When the target pressure is reached, it shall be held for 5 min. Any leakage or axial joint movement of more than 0.150 in. (3.8 mm) shall mean failure.

7.2.4 Support the pipe assemblies in a manner that does not restrain joint movement as shown in Fig. 3.

**8. Markings and Identification**

8.1 Each gasket shall be permanently marked with the manufacturer’s name or U.S. registered trademark, country of origin, the pipe size and class for which it is designed, and Specification C564.

8.2 Each clamp assembly shall be labeled or permanently marked with the manufacturer’s name or U.S. registered trademark, country of origin, the pipe size and class for which

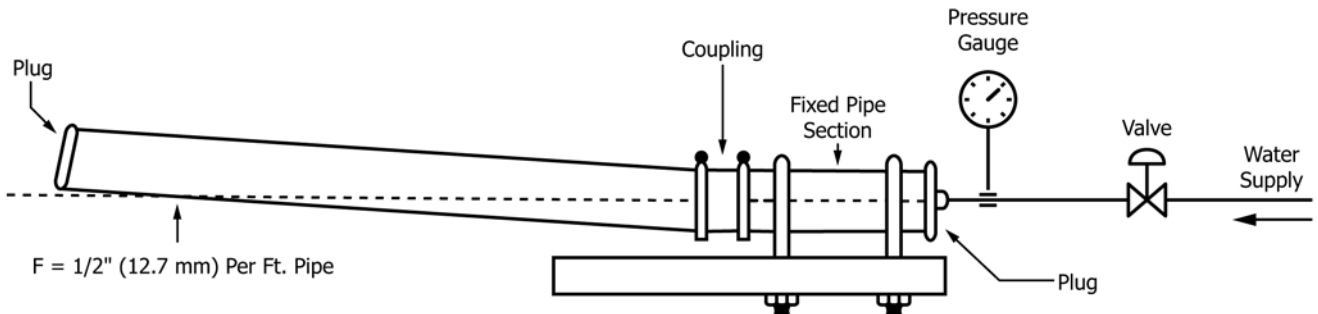

FIG. 1 Deflection Test

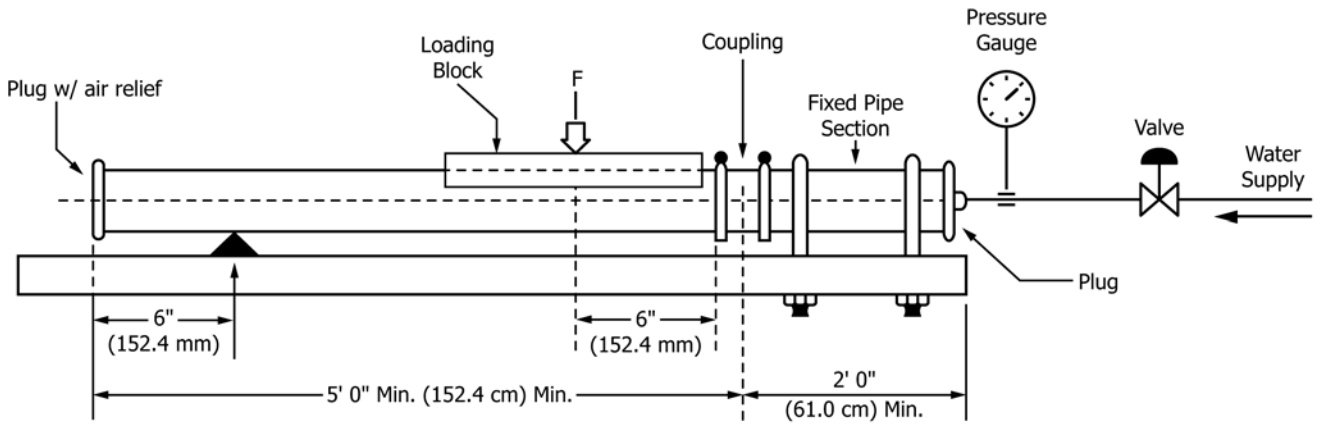

FIG. 2 Shear Test

1. Pressure Regulator
2. Pressure Gauge, 1 psi increments, 0-30 psi
3. Dial Indicator
4. Air Bleed Off Vent
5. Pipe
6. Coupling
7. Alignment Brackets
8. Clamp
9. Test Stand
10. 3/8" Quick Disconnect Coupling
11. 3/8" Rubber hose

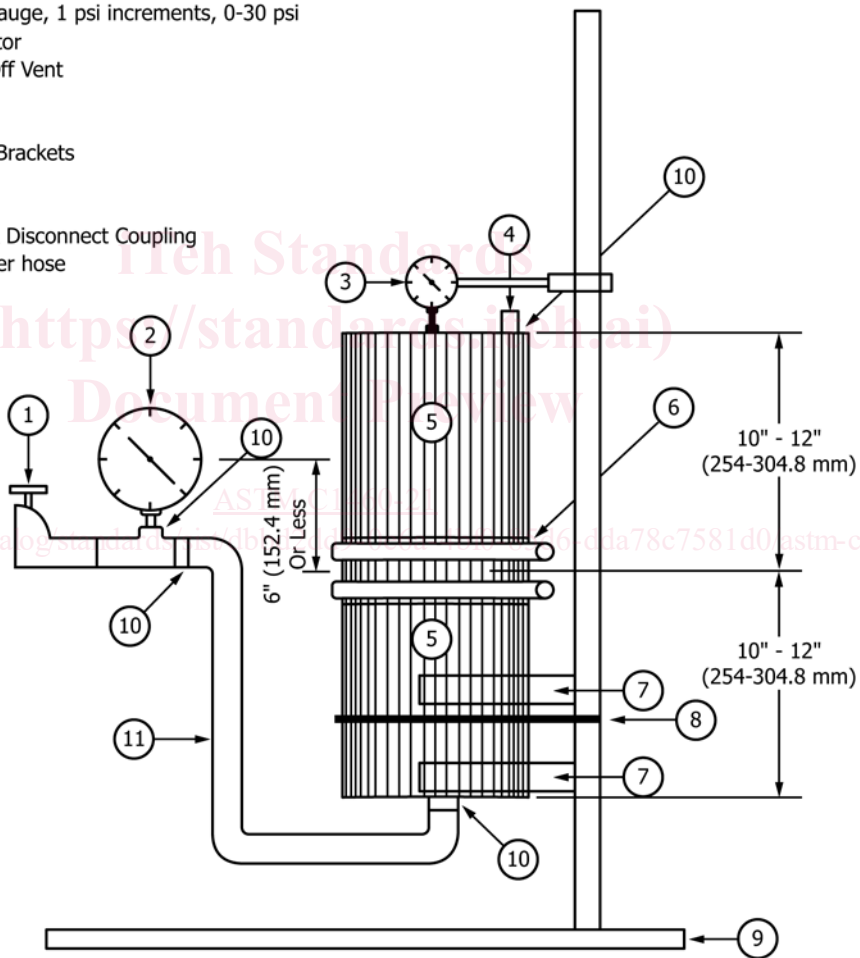

FIG. 3 Unrestrained Hydrostatic Joint Testing Apparatus

it is designed, and Specification C1460. The label or marking shall be visible after installation.