



Designation: C1751 – 21

Standard Guide for Sampling Radioactive Tank Waste¹

This standard is issued under the fixed designation C1751; the number immediately following the designation indicates the year of original adoption or, in the case of revision, the year of last revision. A number in parentheses indicates the year of last reapproval. A superscript epsilon (ϵ) indicates an editorial change since the last revision or reapproval.

1. Scope

1.1 This guide addresses techniques used to obtain samples from tanks containing high-level radioactive waste created during the reprocessing of spent nuclear fuels. Guidance on selecting appropriate sampling devices for waste covered by the Resource Conservation and Recovery Act (RCRA) is also provided by the United States Environmental Protection Agency (EPA) (1).² Vapor sampling of the head-space is not included in this guide because it does not significantly affect slurry retrieval, pipeline transport, plugging, or mixing.

1.2 The values stated in inch-pound units are to be regarded as standard. No other units of measurement are included in this standard.

1.3 *This standard does not purport to address all of the safety concerns, if any, associated with its use. It is the responsibility of the user of this standard to establish appropriate safety, health, and environmental practices and determine the applicability of regulatory limitations prior to use.*

1.4 *This international standard was developed in accordance with internationally recognized principles on standardization established in the Decision on Principles for the Development of International Standards, Guides and Recommendations issued by the World Trade Organization Technical Barriers to Trade (TBT) Committee.*

2. Referenced Documents

2.1 *ASTM Standards:*³

D1129 Terminology Relating to Water

3. Terminology

3.1 *Definitions*—For definitions of terms used in this method, refer to Terminology **D1129**.

¹ This guide is under the jurisdiction of ASTM Committee C26 on Nuclear Fuel Cycle and is the direct responsibility of Subcommittee C26.13 on Spent Fuel and High Level Waste.

Current edition approved Jan. 1, 2021. Published March 2021. Originally approved in 2011. Last previous edition approved in 2020 as C1751 – 20. DOI: 10.1520/C1751-21.

² The boldface numbers in parentheses refer to a list of references at the end of this standard.

³ For referenced ASTM standards, visit the ASTM website, www.astm.org, or contact ASTM Customer Service at service@astm.org. For *Annual Book of ASTM Standards* volume information, refer to the standard's Document Summary page on the ASTM website.

3.2 Definitions of Terms Specific to This Standard:

3.2.1 *forced evaporation, n*—intentional concentration of a waste solution using heat or vacuum, or both, primarily to remove water or other solvents.

3.2.2 *pH modified, n*—a description of a solution where the pH is adjusted with either an acid or base material to achieve a desired pH level to minimize tank corrosion.

3.2.3 *soft sludge, n*—a sludge with a low viscosity where minimal sampling device pressure could be used to penetrate the sludge layer.

3.2.4 *sparge, n*—a process of delivering a chemically inert gas through fluids to displace materials for the purpose of mixing.

3.3 Acronyms:

3.3.1 *EREE*—Extended Reach End-Effector

3.3.2 *HAST*—Highly-Active Storage Tanks

3.3.3 *LDUAs*—Light-Duty Utility Arms

3.3.4 *NPH*—Normal Paraffin Hydrocarbons

3.3.5 *ORNL*—Oak Ridge National Laboratory

3.3.6 *PTFE*—Polytetrafluoroethylene

3.3.7 *PVC*—Polyvinyl Chloride

3.3.8 *RFD*—Reverse-Flow Diverter

4. Significance and Use

4.1 Obtaining samples of high-level waste created during the reprocessing of spent nuclear fuels presents unique challenges. Generally, high-level waste is stored in tanks with limited access to decrease the potential for radiation exposure to personnel. Samples must be obtained remotely because of the high radiation dose from the bulk material and the samples, samples require shielding for handling, transport, and storage. The quantity of sample that can be obtained and transported is small due to the hazardous nature of the samples as well as their high radiation dose.

4.2 Many high-level wastes have been treated to remove strontium (Sr) or cesium (Cs), or both, have undergone liquid volume reductions through pumping and forced evaporation or have been pH modified, or both, to decrease corrosion of the tanks. These processes, as well as waste streams added from multiple process plant operations, often resulted in

precipitation, and produced multiphase wastes that are heterogeneous. Evaporation of water from waste with significant dissolved salts concentrations has occurred in some tanks due to the high heat load associated with the high-level waste and by pumping and intentional evaporative processing, resulting in the formation of a saltcake or crusts, or both. Organic layers exist in some waste tanks, creating additional heterogeneity in the wastes.

4.3 Many of the sampling systems have limitations including the ability to sample varying depths in the tank and the

depth of sampling. Sampling in Hanford tanks is constrained by riser diameter, riser location and riser availability.

4.4 Due to these extraordinary challenges, substantial effort in research and development has been expended to develop techniques to provide grab samples of the contents of the high-level waste tanks. A summary of the primary techniques used to obtain samples from high-level waste tanks is provided in **Table 1**. These techniques will be summarized in this guideline with the assumption that the tank headspace is adequately ventilated during sampling.

TABLE 1 High-Level Waste Tank Sampling Methods

Technique	Material Type			Notes
	Solid	Slurry	Liquid	
HAST in-tank needle orifice			X	Orifice as part of Reverse-Flow Diverter (RFD)
Bottle on a String		X	X	Dip sample
Vacuum Pump		X	X	
Auger	X	X		Only high viscosity slurries
Sample Cup	X	X		Manual system used at Savannah River Site to obtain salt-cake samples and hard sludges that don't slump.
Core Drilling: Rotary Mode (Hanford Sampler)	X	X		Hard sludges and salt-cake.
Core Drilling: Push Mode (ORNL Soft Sludge Sampler)		X	X	Liquid or soft sludges.
Off-Riser Sampling System (ORSS crawler)	X	X		Used to collect sludge samples to support tank closure at Hanford.
Cylinder with retractable nose cone		X	X	Used at Savannah River Site for soft sludges and liquids.
Robotic Arm	X	X	X	Material type captured is dependent upon the end-effector.
Clamshell Sampler	X	X		Used to collect solids samples at Hanford
Fingertrap Sampler	X	X		Used to collect solids samples at Hanford
Drag Sampler	X	X		Used to collect sludge samples to support tank closure at Hanford.
Hydraulic Mining	X	X	X	
Hydraulic Scoop	X	X	X	
Sample Thief (Bacon Bomb)			X	

5. Liquid-Only Sampling Techniques

5.1 Liquid only techniques are common in tank waste sampling at Hanford using the bottle on a string technique. Liquid only samples are also captured by methods used primarily to obtain solid or slurry samples such as core sampling. However, some high-level waste tanks, such as the Highly-Active Storage Tanks (HAST) tanks at Sellafield in the United Kingdom; had sampling systems installed in the tanks before the high-level waste was added. The HAST system uses a needle orifice as part of a Reverse-Flow Diverter (RFD) to obtain samples. The needle orifices are easily plugged by particles; only liquid samples can be obtained by this system. The HAST system design also allows for the agitation of tank contents to help obtain representative liquid samples (2).

6. Slurry/Liquid Sampling Techniques

6.1 The simplest of the liquid sampling techniques is dip sampling. At the Hanford Site, this sampling technique is often referred to as “bottle on a string.” Only liquid or slurry samples can be taken by this method. Samples can be taken at various depths in the tank to determine whether there is vertical heterogeneity in the tank. If data on the stratification in the tank is not needed, waste in the tank should be sparged or mixed before taking the sample to decrease sampling bias.

6.2 A dip sample is taken by lowering a stoppered and weighted bottle into the waste to the desired depth (see Fig. 1). After the bottle has reached the desired level, the stopper is pulled from the bottle and the liquid or slurry sample flows into

the bottle (3). At Hanford the sample bottle is not capped immediately after sampling. Some mixing can occur as the sample is pulled back up through the liquid column.

6.3 Dip sampling is limited to lower viscosity liquid and slurry materials and the effectiveness of sampling is highly dependent upon the size of the sample bottle inlet and the presence of saltcake layers which may prevent sampling access to lower tank levels. Further, sampling locations are limited only to vertical columns directly under a tank penetration, or riser. Particulates obtained from this method may be highly biased due to sample location and variations in settling velocity while sampling.

6.4 Liquid samples from radioactive-waste tanks have also been obtained using a vacuum-pump system. Samples were pulled by vacuum from the specified level in the tank through polytetrafluoroethylene (PTFE) tubing into a sample jar; if necessary, the sample jar could be shielded. A stainless-steel pipe nozzle is attached to the bottom of the PTFE tubing to keep it vertical. A diagram of the vacuum-pump sampling system used at Oak Ridge National Laboratory (ORNL) is provided in Fig. 2 (4).

7. Solids/Slurry Sampling Techniques

7.1 Early sampling of the solids content of Hanford tank wastes was by the use of an auger. Auger samples were taken only from the surface of the waste and were limited to 6 in. This 6 in. limitation was driven primarily by a desire to reduce radiation dose. Some homogenization of the sample occurs



FIG. 1 “Bottle on a String” Sampler

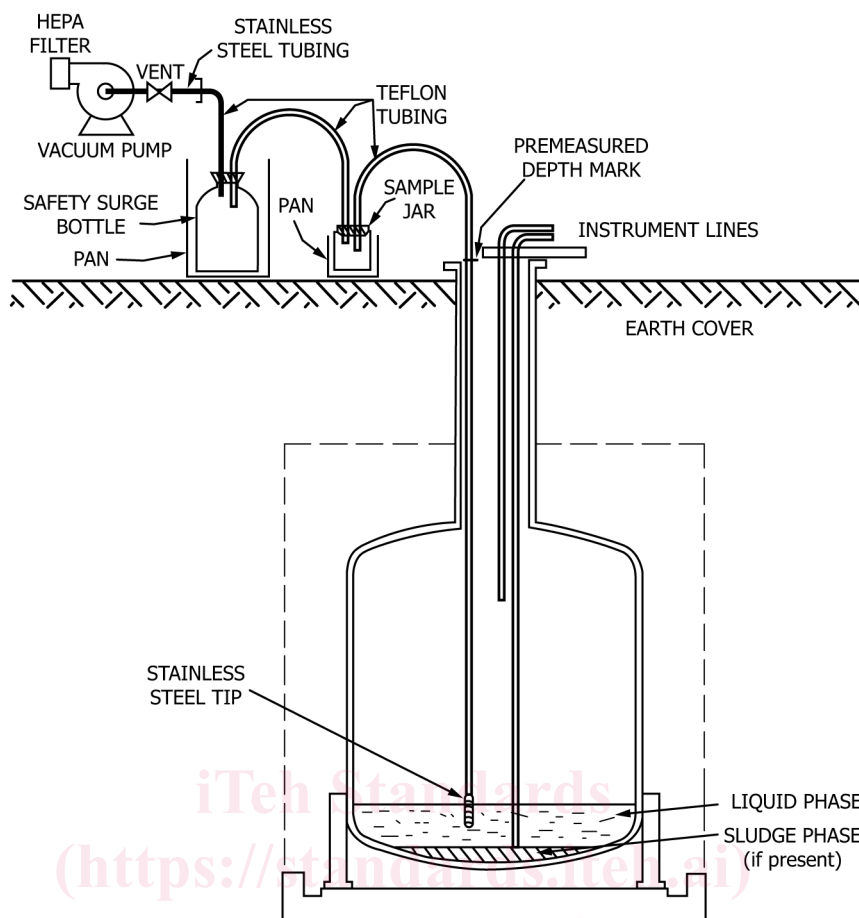

FIG. 2 Vacuum Pump Sampling System

while obtaining auger samples. These samples can only be taken directly beneath a penetration, or riser (5).

7.2 Auger samples are taken by encasing an auger in a shroud to contain the sample. The auger is rotated through the sample while the shroud remains stationary. Sample is collected along the flutes of the auger. Liquid is generally not contained in the auger unless it is associated with solids in the form of a sludge or highly viscous slurry.

7.3 Savannah River Site staff developed a manual method of capturing salt-cake samples from waste tanks. This method incorporates a sample cup pinned to a handle that can be driven into the salt cake. The cup has a sharp edge to allow it to cut through the salt cake as the handle is pounded with a hammer. The bore of the cup has a ledge like a fishhook barb that captures the material once it is forced into the cup. The cup design is shown in Fig. 3 (6). The applicability of this method is limited to hard materials that will not flow or slump once collected in the sample device.

7.4 Historically, core sampling was the primary mechanism for obtaining samples from the Hanford waste. A core-drilling truck with a shielded handler was specifically designed for this purpose. Two modes, push or rotary, can be used to obtain samples. Liquids, slurries, and soft sludges can be obtained in push mode; rotary-mode sampling must be used to obtain samples of harder sludges and salt-cake. Only minimal success

has been achieved when sampling saltcake. A new core sampling platform was designed and implemented at Hanford in 2015 called the Modified Core Sampling System. The new system, although based on the existing system is intended to have a number of improvements including but not limited to the following: provide a safer environment for the personnel involved in operation of the equipment, reduced sampling cost and schedule, reduction in size, weight and smaller component configuration of core drill rig that must interface with risers on top of tank and provide the opportunity to minimize in-farm operations with the ability to co-locate support systems outside of the tank farm. Fig. 4a and b shows the core sampling platform, both as a photograph and schematic (7).

7.5 The Hanford Sampler is based on a modified core-drilling design that is similar to the thief-and-trier-type samplers. Details of the core-drilling truck procedure are provided in Waste Characterization Plan for Hanford Site Single-Shell Tanks (8), (9). Liquid and solid samples are trapped in the sampler by a spring-actuated rotary valve (see Fig. 5). Two different sampler designs have been used, but both designs incorporated the spring-actuated rotary valve. The first design produced samples that were 19 in. long and 1 in. in diameter. The later design had a slightly larger diameter (1.25 in.). It is important to note the design length of this sampler was driven by operational space limitations of the existing hot cells at the

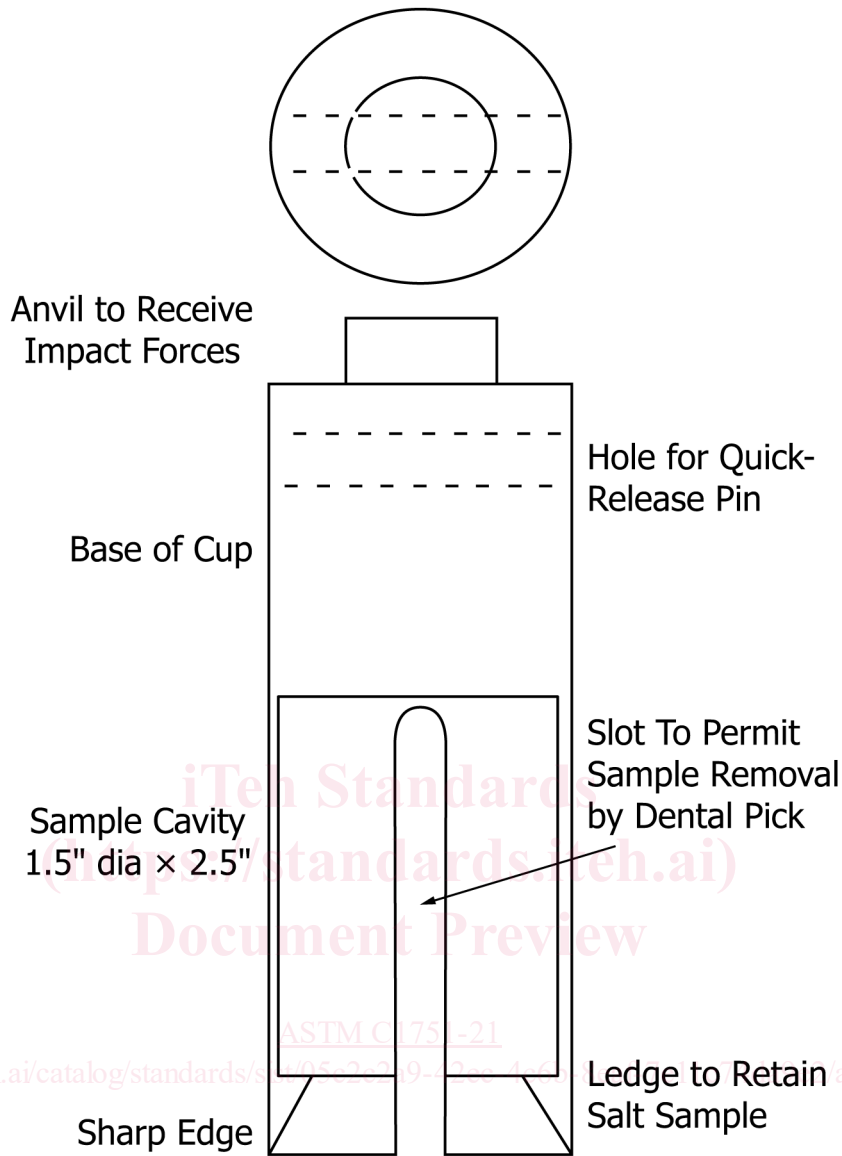

FIG. 3 Savannah River Site Salt-Cake Sample Cup

time. Core samples can be taken at varying depths to obtain samples that comprise the entire depth of the waste. A sliding piston in the sampler controls the height of the sample being collected. A hydrostatic fluid is added via the drill string to keep the waste from slumping into the void created by the sample when the sampler is pulled from the tank. Normal paraffin hydrocarbons (NPH) were initially used as the hydrostatic fluid. Nitrogen gas has also been used.

7.6 A sampler based on the same principle was used at ORNL to obtain samples of soft sludges from waste tanks at that site. Samples are collected by manually pushing a polyvinyl chloride (PVC) pipe with a detachable handle assembly into the sludge in the tank. A bottom closure that can be controlled from above by the operator is incorporated into the sampler Fig. 6. This sampler is capable of capturing both liquid and soft sludge samples. A brief description of the operation of

this sampler is provided in an ORNL technical document describing the sampling and analysis of radioactive waste tanks (4).

7.7 The Savannah River Site developed a similar method for obtaining soft sludges. The sampler is a cylinder with a retractable nose cone at the bottom. Sections of pipe are added to the sampler to lower it to the desired depth in the tank. Penetration into the sludge is achieved by using the collective weight of the sampler and pipe sections. Once the desired depth is achieved, the nose cone is retracted into the cylinder, forming an annulus between the cone and cylinder. Gases and liquids pass through a vent at the top of the cylinder, allowing the sludge to be trapped in the cylinder. After the cylinder is closed, the sampler is raised out of the tank into a shielded cask (10).



FIG. 4 a. Core Sampling Platform

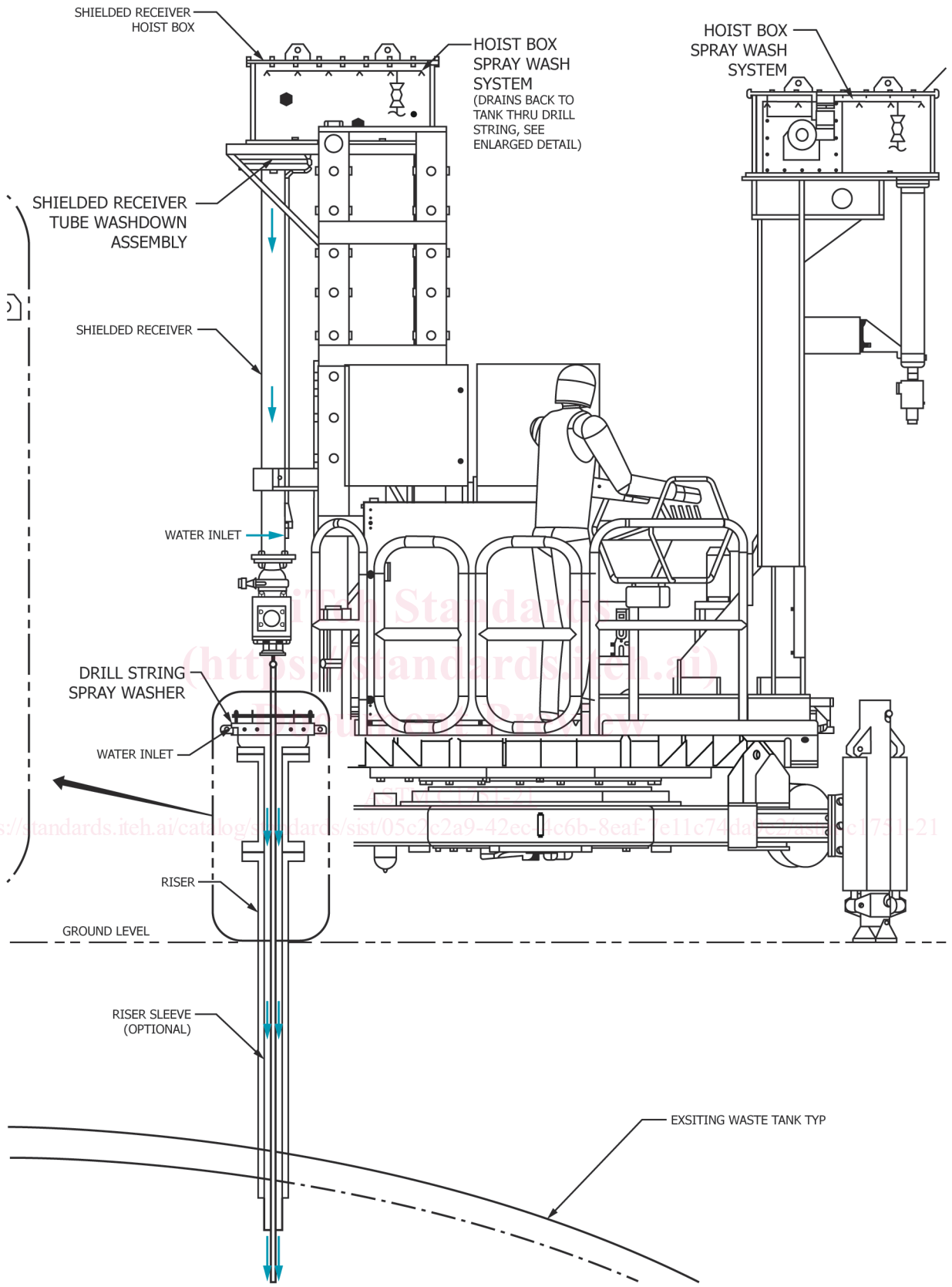

FIG. 4 b. Core Sampling Platform (continued)