



Designation: C501 – 21

Standard Test Method for Relative Resistance to Wear of Unglazed Ceramic Tile by the Taber Abraser¹

This standard is issued under the fixed designation C501; the number immediately following the designation indicates the year of original adoption or, in the case of revision, the year of last revision. A number in parentheses indicates the year of last reapproval. A superscript epsilon (ϵ) indicates an editorial change since the last revision or reapproval.

1. Scope*

1.1 This test method covers the establishment of an abrasive wear index by determination of the loss of weight resulting from abrasion of unglazed ceramic tile. It is applicable to tile described in Definitions [C242](#).

1.2 The values stated in inch-pound units are to be regarded as standard. The values given in parentheses are mathematical conversions to SI units that are provided for information only and are not considered standard.

1.3 *This standard does not purport to address all of the safety concerns, if any, associated with its use. It is the responsibility of the user of this standard to establish appropriate safety, health, and environmental practices and determine the applicability of regulatory limitations prior to use.*

1.4 *This international standard was developed in accordance with internationally recognized principles on standardization established in the Decision on Principles for the Development of International Standards, Guides and Recommendations issued by the World Trade Organization Technical Barriers to Trade (TBT) Committee.*

2. Referenced Documents

2.1 *ASTM Standards:*²

[C242 Terminology of Ceramic Whitewares and Related Products](#)

[G195 Guide for Conducting Wear Tests Using a Rotary Platform Abraser](#)

3. Terminology

3.1 *Definitions:*

3.1.1 For definitions of terms used in this test method, see Terminology [C242](#).

¹ This test method is under the jurisdiction of ASTM Committee [C21](#) on Ceramic Whitewares and Related Products and is the direct responsibility of Subcommittee [C21.06](#) on Ceramic Tile.

Current edition approved Feb. 1, 2021. Published March 2021. Originally approved in 1962. Last previous edition approved in 2015 as C501 – 84 (2015). DOI: 10.1520/C0501-21.

² For referenced ASTM standards, visit the ASTM website, www.astm.org, or contact ASTM Customer Service at service@astm.org. For *Annual Book of ASTM Standards* volume information, refer to the standard's Document Summary page on the ASTM website.

4. Summary of Test Method

4.1 A test specimen is abraded using rotary rubbing action under controlled conditions of pressure and abrasive action. The specimen is mounted on a turntable platform and turns on a vertical axis, against the sliding rotation of two abrading wheels of specified coarseness under a defined applied load. When resting on the specimen, the wheels have a peripheral engagement with the surface of the specimen, the direction of travel of the periphery of the wheels and of the specimen at the contacting portions being at acute angles, and the angles of travel of one wheel periphery being opposite to that of the other. Motion of the abrasive wheels, is provided by rotation of the specimen and the associated friction therefrom, while a vacuum system removes wear debris generated during the test. The resulting abrasion marks form a pattern of crossed arcs over an area of approximately 5 in.² (30 cm²). From the loss of weight due to abrasion, the abrasive wear index is calculated by a given formula.

5. Significance and Use

5.1 This test method provides a means to quantify the abrasion resistance of unglazed ceramic tile and may be related to end-use performance, or used to comparatively rank material performance, or both.

6. Apparatus

6.1 *Abraser*,³ as described in Guide [G195](#) with accessory weights that provide a force of 9.8 N (1000 gf), when the wheel is pressed against the specimen, exclusive of the mass of the wheel itself (see [Fig. 1](#) and [Fig. 3](#)).

NOTE 1—Accessory weight references are per arm (not combined), and include the mass of the pivoted arm.

6.1.1 Drive-pin type specimen holder (optional), including drive pins and sliding mounts in place of the center bolt and nut; may be used to eliminate the need for a center hole in the

³ The sole source of supply of the apparatus known to the committee at this time is Taber Industries, 455 Bryant St., North Tonawanda, NY. If you are aware of alternative suppliers, please provide this information to ASTM International Headquarters. Your comments will receive careful consideration at a meeting of the responsible technical committee,¹ which you may attend.

*A Summary of Changes section appears at the end of this standard

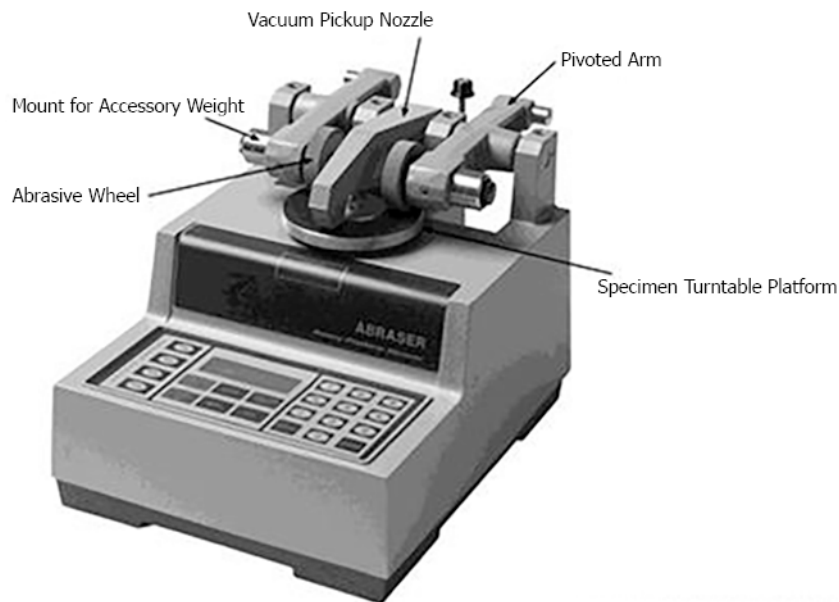

Note: Vacuum Suction System not shown

FIG. 1 Taber Abraser



FIG. 2 Drive-pin Type Specimen Holder (Model E140-19)

test specimen. Model E140-19 has been found satisfactory for this purpose (see Fig. 2).

6.2 *Abrasive Wheels*³—Vitrified H-22 Calibrade wheels are the required grade of abrasive wheel for this test method.

6.2.1 The wheels shall be cylindrically shaped; ½ in. (12.7 mm) thick include an axial hole ⅝ in. (16.0 mm) to allow the wheel to be mounted to the flanged holder on the pivoted arm; and have an external diameter of 2 in. (51.9 mm) when new, and in no case less than 1¾ in. (44.4 mm).

6.3 *Auxiliary Apparatus:*

6.3.1 *Wheel Refacer*,³ with a diamond tool for resurfacing vitrified wheels.

6.3.2 *Mounting Sheet* (optional), double-sided pressure-sensitive adhesive sheet such as type S-37 for securing specimen to drive-pin type specimen holder.

6.4 *Balance*, having a sensitivity of 0.05 g.

7. Sampling

7.1 Four tile specimens 4 in. (102 mm) square or larger, or if ceramic mosaic tile, sufficient tile for four specimen assemblies 4 in. square shall constitute a sample and shall be chosen from the lot to be tested. Only tile that show no visible warpage when checked with a straightedge shall be used.

8. Test Specimen

8.1 The test specimen shall be 4 in. (102 mm) square and in one piece, if possible. If larger, it should be trimmed down to the desired size by removing equal amounts on opposite sides.

NOTE 2—In the case of ceramic mosaic tile where several small units must be used to obtain a 4 in. square specimen assembly, the small units shall be mounted securely on a 4 in. square rigid material, such as a metal plate, by means of a suitable adhesive, and in such a manner that open joints are eliminated and the tile surfaces lie in a plane and are parallel to the metal plate. This can best be accomplished by placing the small tile

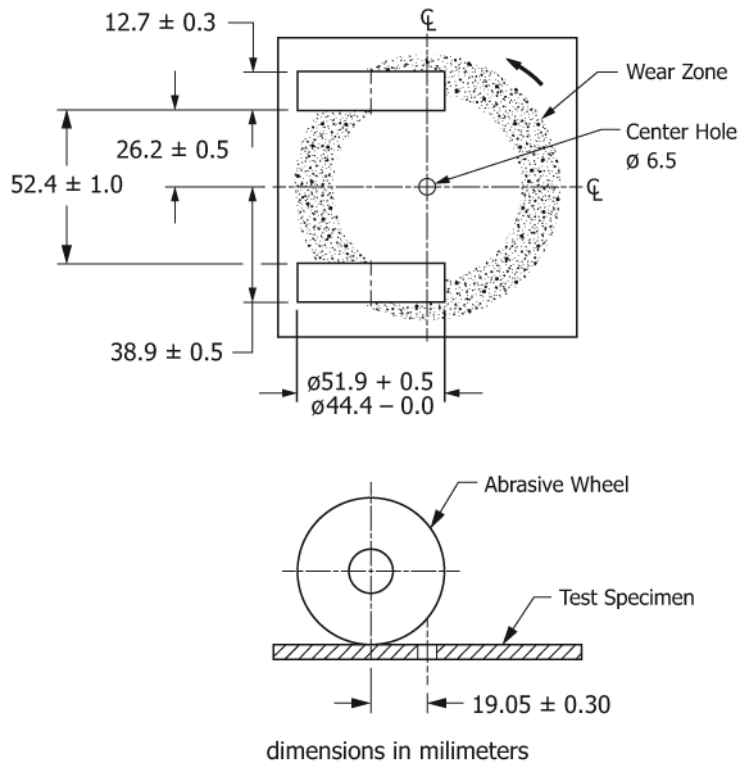

dimensions in millimeters
FIG. 3 Diagrammatic Arrangement of Taber Abraser Test Set-up

units face down and in direct contact with each other on a true plane surface, such as a piece of plate glass, applying a sufficiently thick layer of adhesive to the 4 in. square metal plate that is to form the support of the assembly, and laying the metal plate on the tile units with the adhesive down. Apply a weight of at least 4.4 lb (2 kg) and of the same facial dimensions as the metal plate. If the assembly is kept in this position until the adhesive has set, any difference in thickness of the individual tile units is taken up between the tile and the backing plate and the plane of the face of the tiles will be parallel with the plane of the metal plate.

9. Conditioning

9.1 Prior to testing, condition all specimens as agreed upon by the interested parties.

10. Procedure

10.1 Mount the specimen on the turntable platform by means of the center bolt and nut; the specimen must have a drilled hole at its center for this mounting. If a center bolt mounting is used, the specimen may be weighed alone (without the holder) to ± 0.05 g; record this weight. This mounting is recommended when heavy specimens plus the weight of the holder might exceed the capacity of the available balance.

10.1.1 Alternatively, mount the specimen or specimen assembly on the drive-pin type specimen holder by means of a double-sided pressure-sensitive sheet. Cut the pressure-sensitive sheet to approximately 3 in. (76 mm) square and center it on the specimen. Determine the weight of the specimen and holder assembly to ± 0.05 g and record this weight.

10.2 Mount the specimen holder (turntable platform) on the Taber Abraser equipped with H-22 coarse Calibrade wheels, new or freshly dressed once on the wheel refacer (see Note 3).

Apply a 9.8 N (1000 gf) load to each abrasive wheel and carefully lower the wheels into position on the specimen. Adjust the vacuum pickup nozzle to $\frac{1}{16}$ to $\frac{1}{8}$ in. (1.5 to 3.0 mm) above the specimen.

NOTE 3—Two sets of new H-22 abrasive wheels are required for this method. They shall each be used new and refaced once. There shall be a total of four 1000-cycle runs.

10.3 Subject the specimen to abrasion for a total of 1000 cycles.

10.4 Remove the drive-pin type specimen holder with the specimen and reweigh to ± 0.05 g. Or reweigh the specimen (without the holder) if mounted according to 10.1 (see Note 4).

10.5 Repeat 10.1 – 10.4 for the other three specimens or specimen assemblies.

11. Calculation

11.1 Calculate the abrasive wear index, I_w , expressed in whole numbers, as follows:

$$I_w = \frac{88}{W_o - W_f} \quad (1)$$

where:

W_o = original weight of specimen and holder, g, and
 W_f = final weight of specimen and holder, g.

NOTE 4—If a center bolt mounting has been used, the weight of the holder is not included.

12. Report

12.1 Report the following:

12.1.1 Type and size of tile tested,