



Designation: C1689 – 21

Standard Practice for Subsampling of Uranium Hexafluoride¹

This standard is issued under the fixed designation C1689; the number immediately following the designation indicates the year of original adoption or, in the case of revision, the year of last revision. A number in parentheses indicates the year of last reappraisal. A superscript epsilon (ϵ) indicates an editorial change since the last revision or reappraisal.

1. Scope

1.1 This practice is applicable to subsampling uranium hexafluoride (UF_6), using heat liquefaction techniques, from bulk containers, obtained in conformance with Practices C1052, C1703, and C1883, into smaller sample containers, which are required for laboratory analyses.

1.2 The values stated in SI units are to be regarded as standard. No other units of measurement are included in this standard.

1.3 It is assumed that the liquid UF_6 being sampled comprises a single quality and quantity of material. This practice does not address any special additional arrangement that might be required for taking proportional or composite samples.

1.4 The number of samples to be taken, their nominal sample weight, and their disposition shall be agreed upon between the parties.

1.5 The scope of this practice does not include provisions for preventing criticality incidents.

1.6 *This standard does not purport to address all of the safety concerns, if any, associated with its use. It is the responsibility of the user of this standard to establish appropriate safety, health, and environmental practices and determine the applicability of regulatory limitations prior to use.*

1.7 *This international standard was developed in accordance with internationally recognized principles on standardization established in the Decision on Principles for the Development of International Standards, Guides and Recommendations issued by the World Trade Organization Technical Barriers to Trade (TBT) Committee.*

2. Referenced Documents

2.1 ASTM Standards:²

¹ This practice is under the jurisdiction of ASTM Committee C26 on Nuclear Fuel Cycle and is the direct responsibility of Subcommittee C26.05 on Methods of Test.

Current edition approved Feb. 1, 2021. Published March 2021. Originally approved in 2008. Last previous edition approved in 2014 as C1689 – 08a (2014). DOI: 10.1520/C1689-21.

² For referenced ASTM standards, visit the ASTM website, www.astm.org, or contact ASTM Customer Service at service@astm.org. For *Annual Book of ASTM Standards* volume information, refer to the standard's Document Summary page on the ASTM website.

[C761 Test Methods for Chemical, Mass Spectrometric, Spectrochemical, Nuclear, and Radiochemical Analysis of Uranium Hexafluoride](#)

[C787 Specification for Uranium Hexafluoride for Enrichment](#)

[C859 Terminology Relating to Nuclear Materials](#)

[C996 Specification for Uranium Hexafluoride Enriched to Less Than 5 % ²³⁵U](#)

[C1052 Practice for Bulk Sampling of Liquid Uranium Hexafluoride](#)

[C1703 Practice for Sampling of Gaseous Uranium Hexafluoride for Enrichment](#)

[C1883 Practice for Sampling of Gaseous Enriched Uranium Hexafluoride](#)

2.2 Other Documents:

[ANSI N14.1 Uranium Hexafluoride: Packaging for Transport³](#)

[ISO 7195 Packaging of Uranium Hexafluoride \(\$UF_6\$ \) for Transport⁴](#)

[USEC-651 The \$UF_6\$ Manual: Good Handling Practices for Uranium Hexafluoride, latest revision⁵](#)

3. Terminology

3.1 Definitions:

3.1.1 Terms shall be defined in accordance with Terminology C859 except for the following:

3.1.2 *sample bottle*—the vessel (typically a 1S or 2S bottle) into which the sample of UF_6 is withdrawn from the container for transfer to the laboratory, analysis or dispatch to the customer.

3.1.3 *subsampling tube*—the small vessel (for example, a P10 tube) into which a subsample of UF_6 is withdrawn from the sample bottle for analysis of UF_6 quality or dispatch to the customer.

3.1.3.1 *Discussion*—Polychlorotrifluoroethylene P10 tubes are widely accepted by the industry for subsample collection

³ Available from American National Standards Institute (ANSI), 25 W. 43rd St., 4th Floor, New York, NY 10036, <http://www.ansi.org>.

⁴ Available from International Organization for Standardization (ISO), ISO Central Secretariat, Chemin de Blandonnet 8, CP 401, 1214 Vernier, Geneva, Switzerland, <https://www.iso.org>.

⁵ Available from Centrus Energy Corporation, 6901 Rockledge Drive, Bethesda, MD 20817.

and subsequent UF₆ quality analyses or dispatch to the customer. Other types of subsample tubes, for example P-20, P-80, or P100, can be used for internal subsample collection and processing. Dispatch of these subsample tubes may be agreed upon by buyer and seller and subject to (local) transport regulations.

3.1.4 *subsample rig*—the equipment to perform the transfer of liquid UF₆ from the sample bottle into the subsample tube, typically a vacuum manifold equipped with heating and a liquid nitrogen trap.

4. Summary of Practice

4.1 Two methods of withdrawing a subsample of UF₆ are described which differ based on safety requirements namely: (1) homogenizing of liquefied UF₆ by agitation before liquid transfer, and (2) homogenizing of liquefied UF₆ by convection before liquid transfer. The first method involves homogenization of liquefied UF₆ in a sample bottle by vigorous shaking. Subsequently the sample bottle is inverted and connected to the top of a heated vacuum-manifold system, and the subsample tube is attached to the appropriate port of the system. The system is evacuated and the liquid UF₆ allowed to flow by gravity into the subsample tube. In the second method the sample bottle containing solid UF₆ is connected to the top of a manifold system, and a subsample tube is attached to the appropriate port of the system. The whole system is enclosed in secondary containment that can be heated (hot-box). After evacuation the complete system is heated for specific period (typically >1.5 h) to allow for complete homogenization of the liquid UF₆ by convection. Subsequently the liquid UF₆ is allowed to flow by gravity either directly or via graduated volume into the subsample tube.

4.2 For both methods of sampling, the presence of residues may have significant implications for the quality of UF₆. For safety and quality reasons, sample bottles and subsample tubes shall be clean, dry, and empty before filling.

4.3 Various types of sample bottles and tubes are in use and are described in detail in the applicable national and international standards, for example, ANSI N14.1 and ISO 7195. For a given type of sample bottle, the detailed configuration, for example valve orientation, terminal fittings and the like, may vary. Hence the type and configuration of bottles used for the withdrawal of samples shall be agreed upon between the parties.

5. Significance and Use

5.1 Uranium hexafluoride is normally produced and handled in large (typically 1- to 14-ton) quantities and must, therefore be characterized by reference to representative samples. The samples are used to determine compliance with the applicable commercial Specifications C996 and C787 by means of the appropriate test method (for example, Test Method C761 and references therein). The quantities involved, physical properties, chemical reactivity, and hazardous nature of UF₆ are such that for representative sampling, specially designated equipment must be used and operated in accordance with the most carefully controlled and stringent procedures. This practice indicates appropriate principles, equipment and procedures

currently in use for subsampling of liquid UF₆. It is used by UF₆ converters, enrichers and fuel fabricators to review the effectiveness of existing procedures or to design equipment and procedures for future use. Other subsampling procedures such as UF₆ vapor sampling are not directly representative of the chemical quality of liquid UF₆.

5.2 It is emphasized that this test guide is not meant to address conventional or nuclear criticality safety issues, nor does it address the conditioning of subsample tubes to make them suitable for transport.

6. Apparatus

6.1 *Hot Water Bath*.

6.2 *Subsample Rig*—For Procedures 1 and 2 see Figs. 1 and 2, respectively. Materials of construction in direct contact with liquid UF₆ are made from nickel, high nickel alloys, or materials having comparable resistance to UF₆ corrosion.

6.3 *Gaseous Isotopic Abundance Sample Tube* (Fig. 3).

6.4 *Polychlorotrifluoroethylene Subsample Tube and Closing Disc* (Fig. 4)—The tube must be of uniform density, free from cracks or occlusions and able to withstand temperatures from -195 °C to +150 °C. Materials of construction in direct contact with liquid UF₆ are made from polychlorotrifluoroethylene, PTFE/TFE (gaskets), or materials having comparable resistance to UF₆ corrosion.

6.5 *Flare Nut and Plug*—Flare nuts and plugs for subsample tube closure, storage and transport can be constructed from Monel, nickel, high nickel alloys or 316 SS.

6.6 *Polychlorotrifluoroethylene Knockout Cylinder* (Fig. 5), closed with a Cajon M-16 VCR-1 female nut and an M-16 VCR-4 male nut or equivalent.

NOTE 1—Brand names mentioned in this practice are intended to be typical, not limiting. Another brand with comparable characteristics could perform equally well.

6.7 *Nickel Filter Disc*, porous, 2µm, free of chromium (Fig. 6).

NOTE 2—The filter disc should weigh approximately 1 g. It should be made of nickel powder produced from carbonyl nickel and formed by the no pressure sintering method in graphite or ceramic molds.

6.8 *Gas Sample Cylinder*.

6.9 *Heat Sources*—Heat gun (or an equivalent) and heat lamps.

6.10 *Dewar Flask*, for liquid nitrogen, stainless steel.

7. Hazards

7.1 Uranium hexafluoride (UF₆) is radioactive, toxic, and highly reactive especially with reducing substances and moisture. Appropriate laboratory facilities, materials of construction, and techniques shall be utilized when handling UF₆ (see for example USEC-651).

7.2 Follow all safety procedures for handling uranium and UF₆ provided by the facility. Review the Safety Data Sheet (SDS) for UF₆ prior to performing the procedure.

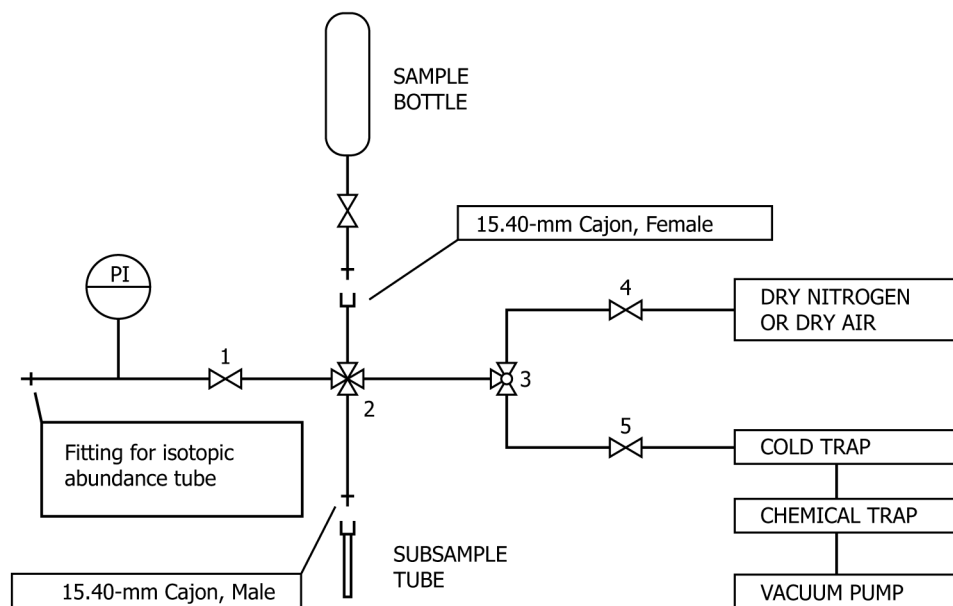

NOTE 1—All lines are 3/8 in. (9.5 mm) Monel tubing.

NOTE 2—All valves are Monel diaphragm type valves.

NOTE 3—The valves and lines are wrapped with heating tape to maintain a system temperature of about 80 °C.

NOTE 4—Valve 2 is a 3-way valve modified to make it a 4-way valve. When the valve is closed, the polychlorotrifluoroethylene tube is isolated from the system, but the lines from valve 1 to valve 3 and to the bulk container are open.

FIG. 1 Subsample Rig Used for Procedure 1

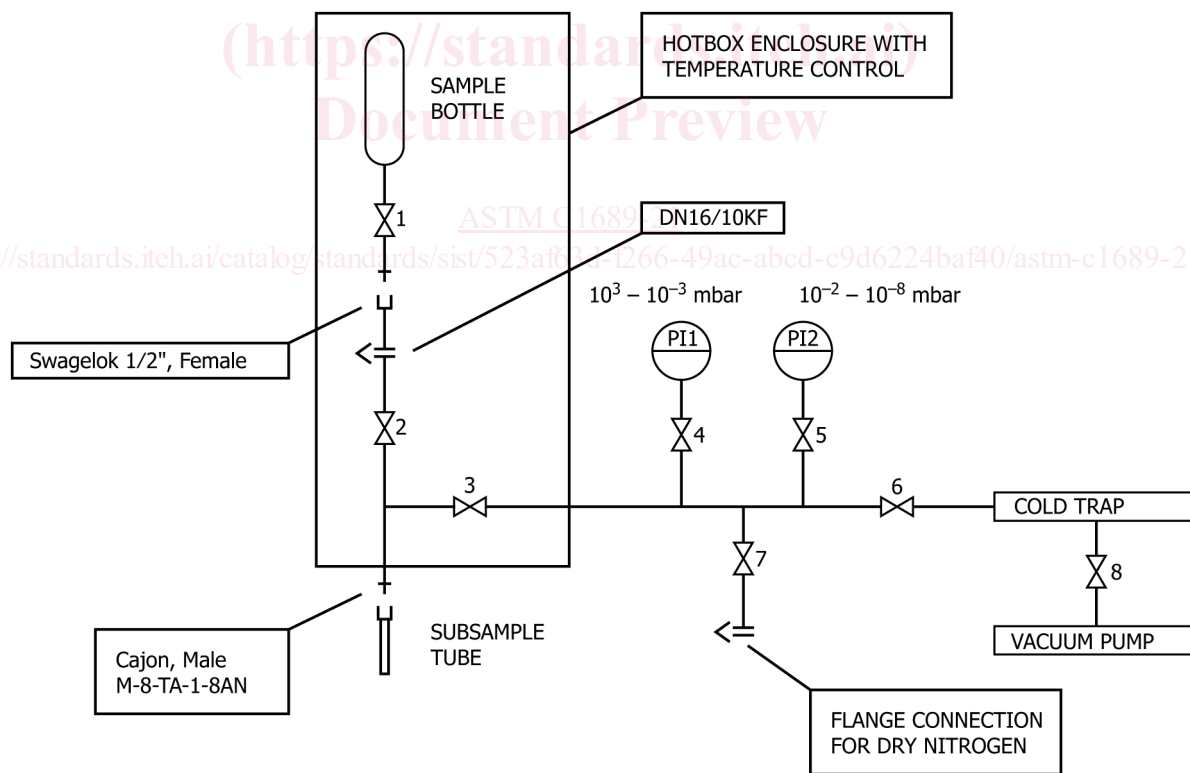

NOTE 1—All lines in direct contact with liquid UF₆ are 9.5 mm Monel tubing.

NOTE 2—All other lines are 9.5 mm 316 SS tubing.

NOTE 3—Valves 1–3 are Monel below sealed valves that can be operated from outside the hotbox.

NOTE 4—Valves 4–8 are 316 SS below sealed valves.

NOTE 5—Flange connections are equipped with (high pressure) gaskets resistant to liquid UF₆, viton and helicoflex have been found to be acceptable for this application

FIG. 2 Subsample Rig Used for Procedure 2

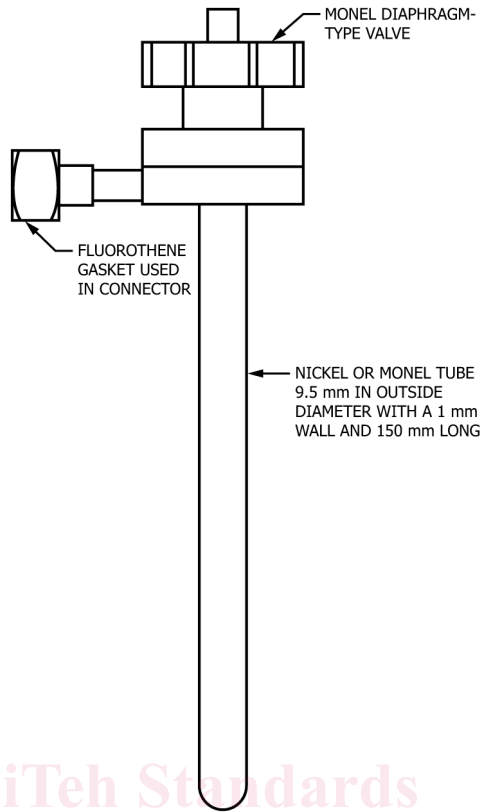

FIG. 3 Isotopic Abundance Sample Tube

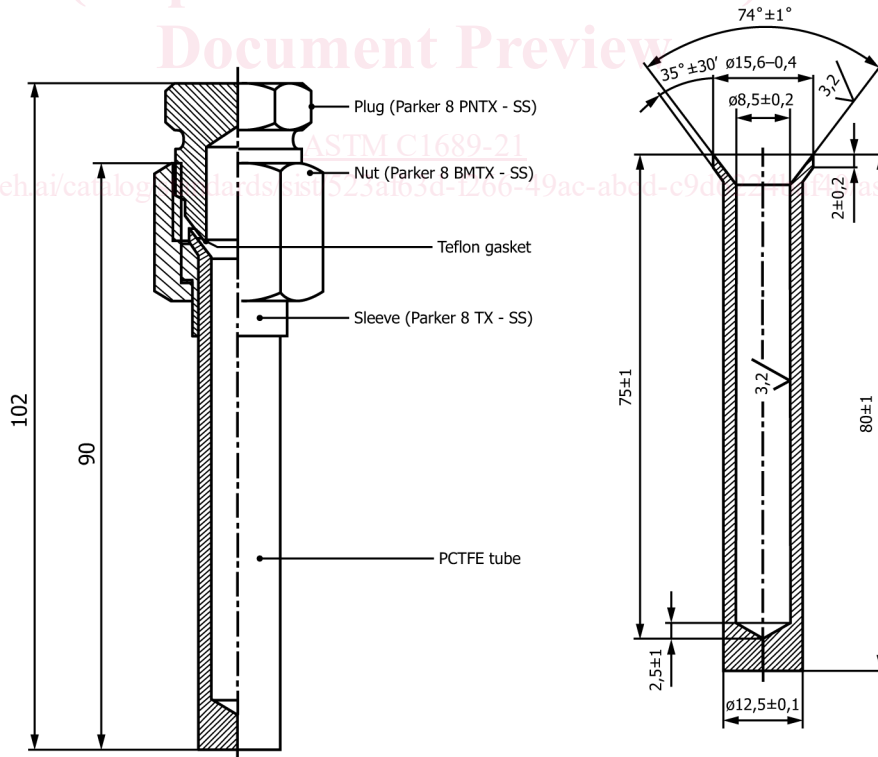

FIG. 4 Example of Polychlorotrifluoroethylene Subsample Tube

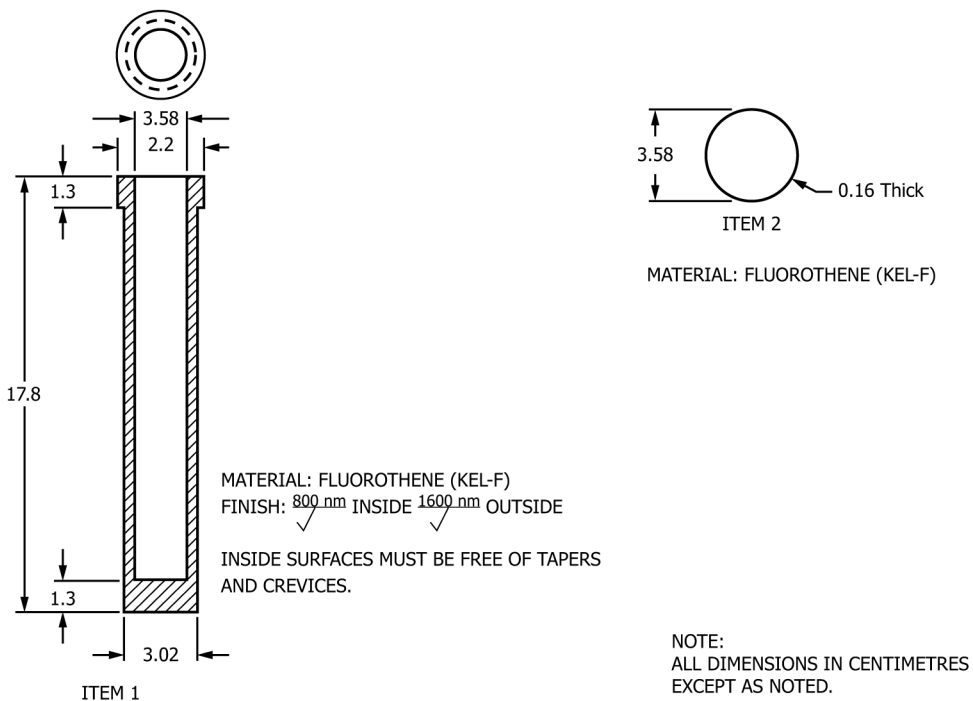

FIG. 5 Example of Polychlorotrifluoroethylene Knock-out Tube

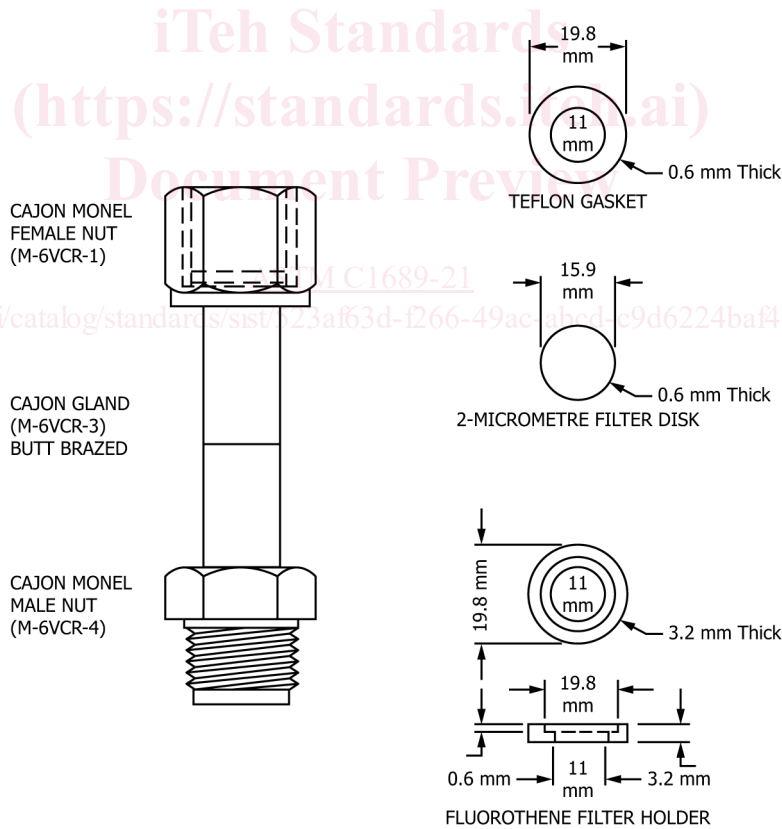

FIG. 6 Filter Disc Unit for Determination of Soluble and Insoluble Chromium