



Designation: **E1875–20** E1875 – 20a

Standard Test Method for Dynamic Young's Modulus, Shear Modulus, and Poisson's Ratio by Sonic Resonance¹

This standard is issued under the fixed designation E1875; the number immediately following the designation indicates the year of original adoption or, in the case of revision, the year of last revision. A number in parentheses indicates the year of last reappraisal. A superscript epsilon (ϵ) indicates an editorial change since the last revision or reappraisal.

1. Scope*

1.1 This test method covers the determination of the dynamic elastic properties of elastic materials. Specimens of these materials possess specific mechanical resonant frequencies that are determined by the modulus of elasticity, mass, and geometry of the test specimen. Therefore, the dynamic elastic properties of a material can be computed if the geometry, mass, and mechanical resonant frequencies of a suitable test specimen of that material can be measured. ~~Dynamic~~ ~~The dynamic Young's modulus is determined using the resonant frequency in the flexural mode of vibration.~~ fundamental flexural resonant frequency. The dynamic shear modulus, or modulus of rigidity, is found using the fundamental torsional resonant vibrations: frequency. Dynamic Young's modulus and dynamic shear modulus are used to compute Poisson's ratio.

1.2 This test method is specifically appropriate for materials that are elastic, homogeneous, and isotropic **(1)**.²

1.3 ~~This test method is specifically appropriate for materials that are elastic, homogeneous, and isotropic (1).~~ Materials of a composite character (particulate, whisker, or fiber reinforced) may be tested by this test method with the understanding that the character (volume fraction, size, morphology, distribution, orientation, elastic properties, and interfacial bonding) of the reinforcement in the test specimen will have a direct effect on the elastic properties. These reinforcement effects ~~must~~ shall be considered in interpreting the test results for composites. ~~This test method is not satisfactory for specimens that have cracks or voids that are major discontinuities in the specimen. Neither is the test method satisfactory when these materials cannot be fabricated in a uniform rectangular or circular cross section.~~

1.4 This test method shall not be used for determination of Poisson's ratio of anisotropic materials.

NOTE 1—For anisotropic materials, Poisson's ratio can have different values in different directions. Due to the lack of symmetry in anisotropic materials, the elasticity tensor cannot be reduced to only two independent numbers, and the simplified relation between E , G , and μ is not valid.

1.5 This test method should not be used for specimens that have cracks or voids that are major discontinuities in the specimen.

1.6 The test method should not be used when materials cannot be fabricated in a uniform rectangular or circular cross section.

1.7 ~~A high-temperature~~ An elevated-temperature furnace and cryogenic ~~cabinet~~ chamber are described for measuring the dynamic elastic moduli as a function of temperature from ~~–195–~~ –195 °C to 1200 °C.

¹ This test method is under the jurisdiction of ASTM Committee E28 on Mechanical Testing and is the direct responsibility of Subcommittee E28.04 on Uniaxial Testing. Current edition approved April 15, 2020/Dec. 1, 2020. Published May 2020/March 2021. Originally approved in 1997. Last previous edition approved in 2013/2020 as E1875-13-20. DOI: 10.1520/E1875-20.10.1520/E1875-20A.

² The boldface numbers in parentheses refer to a list of references at the end of this standard.

*A Summary of Changes section appears at the end of this standard

1.8 ~~Modification of this~~ This test method may be modified for use in quality ~~control is possible~~ control. A range of acceptable resonant frequencies is determined for a specimen with a particular geometry and mass. Any specimen with a frequency response falling outside this frequency range is rejected. The actual modulus of each specimen need not be determined as long as the limits of the selected frequency range are known to include the resonant frequency that the specimen must possess if its geometry and mass are within specified tolerances.

1.9 There are material-specific ASTM standards that cover the determination of ~~resonance~~ resonant frequencies and elastic properties of specific materials by sonic resonance or by impulse excitation of vibration. Test Methods [C215](#), [C623](#), [C747](#), [C848](#), [C1198](#), [C1259](#) and ~~E1259~~ [E1259](#) ~~may~~ and [C1548](#) differ from this test method in several areas (for example; sample specimen size, dimensional tolerances, sample specimen preparation). The testing of these materials shall be done in compliance with these material specific standards. Where possible, the procedures, sample specimen specifications, and calculations are consistent with these test methods.

1.10 A separate standard, Test Method [E1876](#), governs determination of dynamic elastic moduli by impulse excitation instead of sonic resonance.

1.11 The values stated in SI units are to be regarded as standard. No other units of measurement are included in this standard.

1.12 *This standard does not purport to address all of the safety concerns, if any, associated with its use. It is the responsibility of the user of this standard to establish appropriate safety, health, and environmental practices and determine the applicability of regulatory limitations prior to use.*

1.13 *This international standard was developed in accordance with internationally recognized principles on standardization established in the Decision on Principles for the Development of International Standards, Guides and Recommendations issued by the World Trade Organization Technical Barriers to Trade (TBT) Committee.*

2. Referenced Documents

2.1 ASTM Standards:³

- [C215](#) Test Method for Fundamental Transverse, Longitudinal, and Torsional Resonant Frequencies of Concrete Specimens
- [C623](#) Test Method for Young's Modulus, Shear Modulus, and Poisson's Ratio for Glass and Glass-Ceramics by Resonance
- [C747](#) Test Method for Moduli of Elasticity and Fundamental Frequencies of Carbon and Graphite Materials by Sonic Resonance
- [C848](#) Test Method for Young's Modulus, Shear Modulus, and Poisson's Ratio For Ceramic Whitewares by Resonance
- [C1198](#) Test Method for Dynamic Young's Modulus, Shear Modulus, and Poisson's Ratio for Advanced Ceramics by Sonic Resonance
- [C1259](#) Test Method for Dynamic Young's Modulus, Shear Modulus, and Poisson's Ratio for Advanced Ceramics by Impulse Excitation of Vibration
- [C1548](#) Test Method for Dynamic Young's Modulus, Shear Modulus, and Poisson's Ratio of Refractory Materials by Impulse Excitation of Vibration
- [E6](#) Terminology Relating to Methods of Mechanical Testing
- [E177](#) Practice for Use of the Terms Precision and Bias in ASTM Test Methods
- [E691](#) Practice for Conducting an Interlaboratory Study to Determine the Precision of a Test Method
- [E1876](#) Test Method for Dynamic Young's Modulus, Shear Modulus, and Poisson's Ratio by Impulse Excitation of Vibration

3. Terminology

3.1 *Definitions:* Terms common to mechanical ~~testing~~ testing that appear in Terminology [E6](#) and are listed in this section apply to this test method. In addition, the terms indicated temperature and specified temperature are used as defined in Terminology [E6](#).

3.1.1 *dynamic mechanical measurement, n*—a technique in which either the modulus or damping, or both, of a substance under oscillatory applied force or displacement is measured as a function of temperature, frequency, or time, or a combination thereof.

3.1.2 *dynamic Young's modulus, E_d [FL^{-2}], n*—the value of the Young's modulus determined using an oscillatory applied force or displacement and in conformance with this test method.

³ For referenced ASTM standards, visit the ASTM website, www.astm.org, or contact ASTM Customer Service at service@astm.org. For *Annual Book of ASTM Standards* volume information, refer to the standard's Document Summary page on the ASTM website.

3.1.3 dynamic shear modulus, G_d [FL⁻²], n —the value of the shear modulus determined using an oscillatory applied force or displacement and in conformance with this test method.

3.1.4 *elastic limit* [FL⁻²], n —the greatest stress that a material is capable of sustaining without permanent strain remaining upon complete release of the stress.

3.1.4.1 *Discussion*—

Due to practical considerations in determining the elastic limit, measurements of strain using a small force, rather than zero force, are usually taken as the initial and final reference. ~~_____ (E6)~~

3.1.5 *modulus of elasticity* [FL⁻²], n —the ratio of stress to corresponding strain below the proportional limit.

3.1.5.1 *Discussion*—

The stress-strain relationships of many materials do not conform to Hooke’s law throughout the elastic range, but deviate therefrom even at stresses well below the elastic limit. For such materials, the slope of either the tangent to the stress-strain curve at the origin or at a low stress, the secant drawn from the origin to any specified point on the stress-strain curve, or the chord connecting any two specified points on the stress-strain curve is usually taken to be the “modulus of elasticity.” In these cases, the modulus should be designated as the “tangent modulus,” the “secant modulus,” or the “chord modulus,” and the point or points on the stress-strain curve described. Thus, for materials where the stress-strain relationship is curvilinear rather than linear, one of the four following terms may be used:

(a) *initial tangent modulus* [FL⁻²], n —the slope of the stress-strain curve at the origin.

(b) *tangent modulus* [FL⁻²], n —the slope of the stress-strain curve at any specified stress or strain.

(c) *secant modulus* [FL⁻²], n —the slope of the secant drawn from the origin to any specified point on the stress-strain curve.

(d) *chord modulus* [FL⁻²], n —the slope of the chord drawn between any two specified points on the stress-strain curve below the elastic limit of the material.

3.1.5.2 *Discussion*—

Modulus of elasticity, like stress, is expressed in force per unit of area (pounds per square inch, etc.).

3.1.6 *Poisson’s ratio*, μ , n —the negative of the ratio of transverse strain to the corresponding axial strain resulting from an axial stress below the proportional limit of the material.

3.1.6.1 *Discussion*—

Poisson’s ratio ~~may can~~ be negative for some materials, for example, a tensile transverse strain will result from a tensile axial strain.

3.1.6.2 *Discussion*—

Poisson’s ratio will have more than one value if the material is not isotropic. ~~_____ (E6)~~

3.1.7 *proportional limit* [FL⁻²], n —the greatest stress that a material is capable of sustaining without deviation from proportionality of stress to strain (Hooke’s law).

3.1.7.1 *Discussion*—

Many experiments have shown that values observed for the proportional limit vary greatly with the sensitivity and accuracy of the testing equipment, eccentricity of loading, the scale to which the stress-strain diagram is plotted, and other factors. When determination of proportional limit is required, the procedure and the sensitivity of the test equipment should be specified. ~~_____ (E6)~~

3.1.8 *shear modulus (G) modulus, G* [FL⁻²], n —the ratio of shear stress to corresponding shear strain below the proportional limit, also called *torsional modulus* and *modulus of rigidity*.

3.1.8.1 *Discussion*—

The value of the shear modulus ~~may can~~ depend on the direction in which it is measured if the material is not isotropic. Wood, many plastics and certain metals are markedly anisotropic. Deviations from isotropy should be suspected if the shear modulus differs from that determined by substituting independently measured values of Young’s modulus, E , and Poisson’s ratio, μ , in the relation: relation:

$$G = E/[2(1+\mu)]$$

$$G = \frac{E}{2(1+\mu)}$$

3.1.8.2 *Discussion*—

~~In general, it is advisable in When reporting values of shear modulus to state modulus, the range of stress over which it is measured.~~ measured should be stated.

3.1.9 *Young's modulus* (*E*) *modulus, E* [FL⁻²], *n*—the ratio of tensile or compressive stress to corresponding strain below the proportional limit of the material. (E6)

3.2 *Definitions of Terms Specific to This Standard:*

3.2.1 *anti-nodes, n*—two or more locations in an unconstrained slender ~~rod~~rectangular or ~~bar~~cylindrical specimen in resonance that have local maximum displacements.

3.2.1.1 *Discussion*—

For the fundamental ~~flexure~~flexural resonance, the anti-nodes are located at the two ends and the center of the specimen.

3.2.2 *elastic, adj*—the property of a material such that an application of stress within the elastic limit of that material making up the body being stressed will cause an instantaneous and uniform deformation that will be eliminated upon removal of the stress, with the body returning instantly to its original size and shape without energy loss.

3.2.2.1 *Discussion*—

Most elastic materials conform to this definition well enough to make this resonance test valid.

3.2.3 *flexural vibrations, n*—oscillations that occur in a slender ~~rod~~rectangular or ~~bar~~cylindrical specimen in a vertical plane normal to the length dimension.

3.2.4 *homogeneous, adj*—the condition of a specimen such that the composition and density are uniform, such that any smaller specimen taken from the original is representative of the whole.

3.2.4.1 *Discussion*—

Practically, as long as the geometrical dimensions of the test specimen are large with respect to the size of individual grains, crystals, or components, the body can be considered homogeneous.

3.2.5 *isotropic, adj*—the condition of a specimen such that the values of the elastic properties are the same in all directions in the material.

3.2.5.1 *Discussion*—

Materials are considered isotropic on a macroscopic scale, if they are homogeneous and there is a random distribution and orientation of phases, crystallites, and components.

3.2.6 *nodes, n*—one or more locations of a slender ~~rod~~rectangular or ~~bar~~cylindrical specimen in resonance that have a constant zero displacement.

3.2.6.1 *Discussion*—

For the fundamental flexural resonance, the nodes are located at 0.224 *L* from each end, where *L* is the length of the specimen.

3.2.7 *resonance, n*—state of slender ~~rod~~rectangular or ~~bar~~cylindrical specimen driven into one of the modes of vibration described in 3.2.3 or 3.2.9 when the imposed frequency is such that the resultant displacements for a given amount of driving force are at a maximum.

3.2.7.1 *Discussion*—

The resonant frequencies are natural vibration frequencies that are determined by the modulus of elasticity, mass, and dimensions of the test specimen.

3.2.8 *slender ~~rod~~rectangular or ~~bar~~cylindrical specimen, n*—in dynamic ~~elastic property testing, mechanical measurement,~~ a specimen whose ratio of length to minimum cross-sectional dimension is at least five and ~~preferably should be~~ in the range from 20 to 25.

3.2.9 *torsional vibrations, n*—oscillations that occur in each cross-sectional plane of a slender ~~rod~~rectangular or ~~bar~~cylindrical specimen, such that the plane twists around the length dimension axis.

4. Summary of Test Method

4.1 This test method measures the resonant frequencies of test specimens of suitable geometry by exciting them at continuously variable frequencies. Mechanical excitation of the ~~bars~~specimen is provided through the use of a driving transducer that transforms a cyclic electrical signal into a cyclic mechanical force on the specimen. A ~~second~~detecting transducer senses the resulting mechanical vibrations of the specimen and transforms them into an electrical signal. The amplitude and frequency of the signal

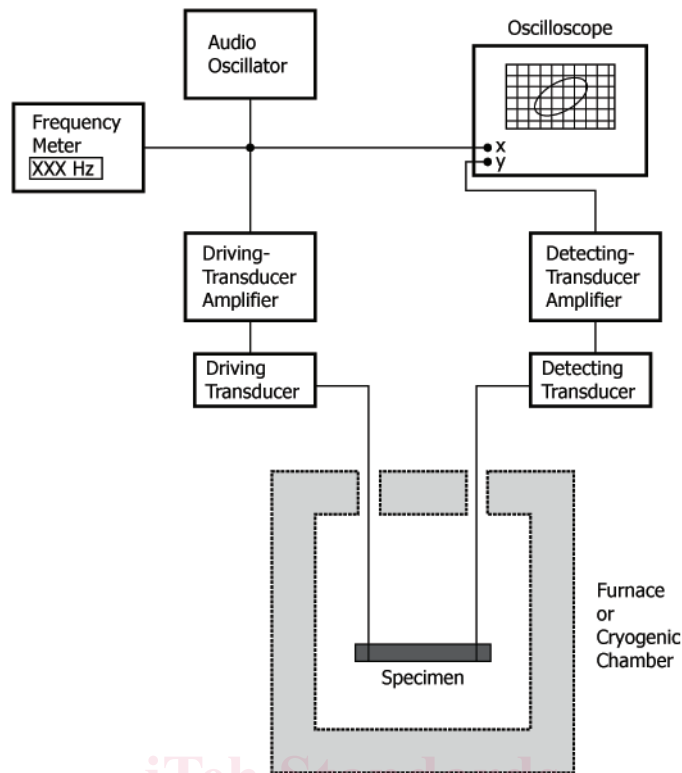

FIG. 1 Block Diagram of a Typical Test Apparatus

(<https://standards.iteh.ai>)

are measured by an oscilloscope or other means to detect resonance. The resonant frequencies, dimensions, and mass of the specimen are used to calculate dynamic Young's modulus and dynamic shear modulus.

5. Significance and Use

ASTM E1875-20a

5.1 This test method has advantages in certain respects over the use of static loading systems for measuring moduli. 5-20a

5.1.1 This test method is nondestructive in nature. Only minute stresses are applied to the specimen, thus minimizing the possibility of fracture.

5.1.2 The period of time during which measurement stress is applied and removed is of the order of hundreds of microseconds. With this test method it is feasible to perform measurements at high elevated temperatures, where delayed elastic and creep effects would invalidate modulus of elasticity measurements calculated from static loading.

5.2 This test method is suitable for detecting whether a material meets the specifications, if cognizance is given to one important fact in materials are often sensitive to thermal history. Therefore, the thermal history of a test specimen must be considered in comparing experimental values of moduli to reference or standard values. Specimen descriptions should include any specific thermal treatments that the specimens have received.

6. Apparatus

6.1 The test apparatus is shown in Fig. 1. It consists of a variable-frequency audio oscillator, used to generate a sinusoidal voltage, and a power amplifier and suitable driving transducer to convert the electrical signal to a mechanical driving vibration. A frequency meter (~~preferably digital~~) meter, which should be digital, monitors the audio oscillator output to provide an accurate frequency determination. A suitable suspension-coupling system supports the test specimen. ~~Another transducer acts to detect~~ A detecting transducer senses the mechanical vibration in the specimen and to convert it into an electrical signal that is passed through an amplifier and displayed on an indicating meter. The meter may be a voltmeter, microammeter, or oscilloscope. ~~An oscilloscope is recommended~~ should be used, because it enables the operator to positively identify resonances, including higher order harmonics, by Lissajous figure analysis. ~~If a Lissajous figure is desired, the output of the oscillator is also coupled to audio oscillator should~~

be displayed on the horizontal ~~plates~~axis of the oscilloscope. If temperature-dependent data are desired, a suitable furnace or cryogenic chamber ~~is~~shall be used. Details of the equipment are as follows:

6.2 *Audio Oscillator*, having a continuously variable frequency output from about 100 Hz to at least 30 kHz. Frequency drift shall not exceed 1 Hz/min for any given setting.

6.3 *Audio Driving-transducer Amplifier*, having a power output sufficient to ensure that the ~~type of driving~~ transducer used can excite any specimen the mass of which falls within a specified range.

6.4 *Transducers*—Two are required; one used as a driver may be a speaker of the tweeter type or a magnetic cutting head or other similar device depending on the type of coupling chosen for use between the transducer and the specimen. The other transducer, used as a detector, may be a crystal or magnetic reluctance type of phonograph cartridge. A capacitive pickup may be used if desired. An electromagnetic coupling system with an attached metal foil may also be used, with due consideration for effects of the foil on the natural vibration of the test bar. The frequency response of the transducer across the frequency range of interest shall have at least a 6.5 kHz bandwidth before -3 dB power loss occurs.~~transducers shall be used.~~

6.4.1 The driving transducer may be a speaker of the tweeter type, or a magnetic cutting head, or other similar device depending on the type of coupling chosen for use between the driving transducer and the specimen.

6.4.2 The detecting transducer may be a crystal or magnetic reluctance type of phonograph cartridge or a capacitive pickup. An electromagnetic coupling system with an attached metal foil may also be used, with due consideration for effects of the foil on the natural vibration of the test specimen. The frequency response of the detecting transducer across the frequency range of interest shall have at least a 6.5 kHz bandwidth before -3 dB power loss occurs.

6.5 *Power Detecting-transducer Amplifier*, in the detector circuit shall be impedance matched with the type of ~~detector~~detecting transducer selected and shall serve as a ~~prescope amplifier~~preamplifier for the oscilloscope.

6.6 *Oscilloscope*, any model suitable for general laboratory work.

6.7 *Frequency Counter, Meter*, preferably should be digital, and shall be able to measure frequencies to within ± 1 Hz.

6.8 *Furnace*—~~If~~For data at an elevated temperature are desired, elevated temperature, a furnace shall be used that is capable of controlled heating and cooling. It shall have a specimen zone large enough for the specimen to be uniform in temperature within ± 5 °C along its length through the range of ~~temperatures encountered in testing~~. It is recommended that an independent thermocouple be placed in close proximity to (within 5 mm), but not touching, the center of the specimen to accurately measure temperature during heating and cooling.specified temperatures.

6.8.1 An independent thermocouple should be placed in close proximity to (within 5 mm), but not touching, the center of the specimen to accurately measure temperature during heating and cooling. Ensure that the indicated temperature from the remote thermocouple and the specimen temperature do not differ.

6.9 *Cryogenic Chamber*—For data at cryogenic temperatures, ~~any~~the cryogenic chamber shall suffice that shall be capable of controlled heating/cooling, frost-free and heating and cooling, frost-free, and uniform in temperature within ± 5 °C over the length of the specimen at any ~~selected~~specified temperature. A suitable cryogenic chamber is shown in Fig. 2 (2). It is recommended that an independent thermocouple be placed in close proximity to (within 5 mm), but not touching, the center of the specimen to accurately measure temperature during heating and cooling.

6.9.1 An independent thermocouple should be placed in close proximity to (within 5 mm), but not touching, the center of the specimen to accurately measure temperature during heating and cooling. Ensure that the indicated temperature from the remote thermocouple and the specimen temperature do not differ.

6.10 *Specimen Suspension*—~~Any~~The method of specimen suspension shall be ~~used that is~~adequate for the temperatures encountered in testing and that allows specified temperatures and allow the specimen to vibrate without significant restriction. Thread suspension is the system of choice ~~should be~~used for cryogenic and high-temperatureelevated-temperature testing. (See Fig. 1 and Fig. 3.) Common cotton thread, silica-glass fiber thread, oxidation-resistant nickel (or platinum) alloy wire, or platinum

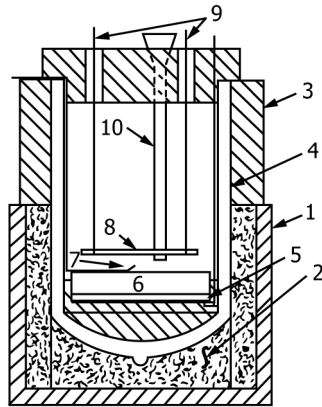

- NOTE 1—Legend:
- 1 = Cylindrical glass jar
 - 2 = Glass wool
 - 3 = Plastic foam
 - 4 = Vacuum jar
 - 5 = Heater disk
 - 6 = Copper plate
 - 7 = Thermocouple
 - 8 = Sample Specimen
 - 9 = Suspension wires
 - 10 = Fill port for liquid

FIG. 2 Detail Drawing of a Typical Cryogenic Chamber

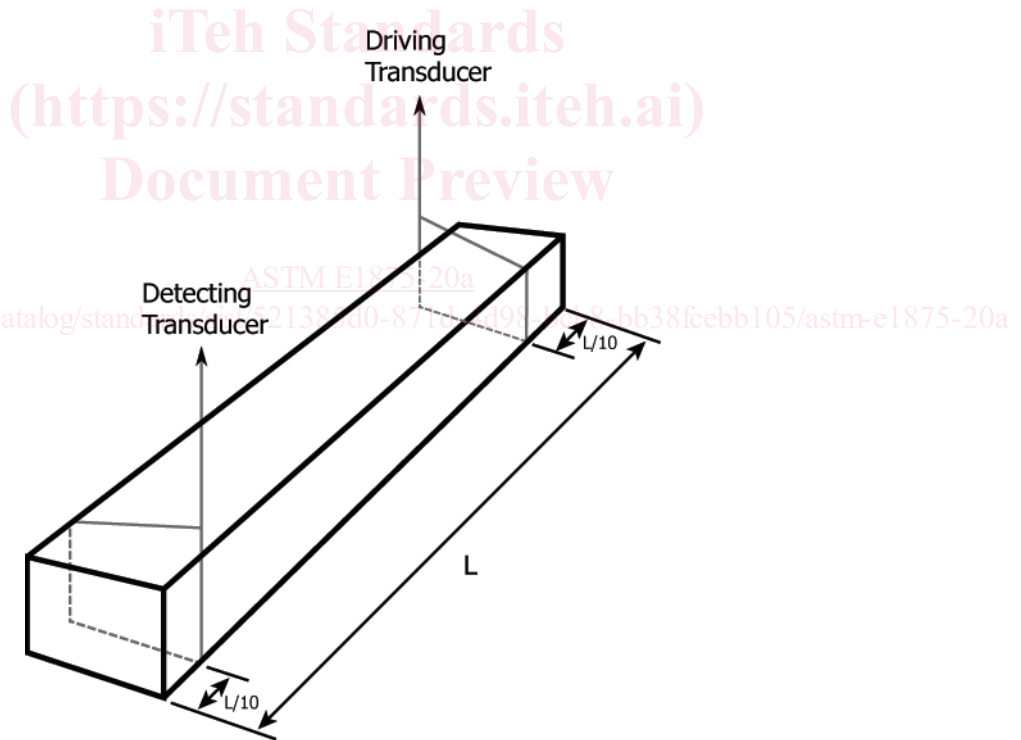

FIG. 3 Specimen Positioned for Measurement of Flexural and Torsional Resonant Frequencies Using Thread or Wire Suspension

wire may be used. If metal wire suspension is used in the furnace, coupling characteristics will be improved if, outside the temperature zone, the wire is coupled to cotton thread, and the thread is coupled to the transducer. The specimen should be initially suspended at distances of approximately $0.1 L$ from each end. The specimen should not be suspended at its fundamental flexural node locations ($0.224 L$ from each end). The suspension point distances ~~can~~ may be adjusted experimentally to maximize the vibrational deflection and resulting signal. For torsional vibration, the axes of suspension shall be off-center from the longitudinal axis of the specimen (shown in Fig. 3).