



Designation: D6641/D6641M – 16^{ε2}

Standard Test Method for Compressive Properties of Polymer Matrix Composite Materials Using a Combined Loading Compression (CLC) Test Fixture¹

This standard is issued under the fixed designation D6641/D6641M; the number immediately following the designation indicates the year of original adoption or, in the case of revision, the year of last revision. A number in parentheses indicates the year of last reappraisal. A superscript epsilon (ϵ) indicates an editorial change since the last revision or reappraisal.

^{ε1} NOTE—A label in Figure 3 was corrected editorially in March 2017.

^{ε2} NOTE—Editorial corrections were made to the adjunct information in March 2021.

1. Scope

1.1 This test method determines the compressive strength and stiffness properties of polymer matrix composite materials using a combined loading compression (CLC) (1)² test fixture. This test method is applicable to general composites that are balanced and symmetric. The specimen may be untabbed (Procedure A) or tabbed (Procedure B), as required. One requirement for a successful test is that the specimen ends do not crush during the test. Untabbed specimens are usually suitable for use with materials of low orthotropy, for example, fabrics, chopped fiber composites, and laminates with a maximum of 50 % 0° plies, or equivalent (see 6.4). Materials of higher orthotropy, including unidirectional composites, typically require tabs.

1.2 The compressive force is introduced into the specimen by combined end- and shear-loading. In comparison, Test Method D3410/D3410M is a pure shear-loading compression test method and Test Method D695 is a pure end-loading test method.

1.3 Unidirectional (0° ply orientation) composites as well as multi-directional composite laminates, fabric composites, chopped fiber composites, and similar materials can be tested.

1.4 The values stated in either SI units or inch-pound units are to be regarded separately as standard. Within the test the inch-pound units are shown in brackets. The values stated in each system are not exact equivalents; therefore, each system must be used independently of the other. Combining values from the two systems may result in nonconformance with the standard.

¹ This test method is under the jurisdiction of ASTM Committee D30 on Composite Materials and is the direct responsibility of Subcommittee D30.04 on Lamina and Laminate Test Methods.

Current edition approved Nov. 1, 2016. Published November 2016. Originally approved in 2001. Last previous edition approved in 2014 as D6641/D6641M-14. DOI: 10.1520/D6641_D6641M-16E02.

² Boldface numbers in parentheses refer to the list of references at the end of this test method.

NOTE 1—Additional procedures for determining the compressive properties of polymer matrix composites may be found in Test Methods D3410/D3410M, D5467/D5467M, and D695.

1.5 *This standard does not purport to address all of the safety concerns, if any, associated with its use. It is the responsibility of the user of this standard to establish appropriate safety, health, and environmental practices and determine the applicability of regulatory limitations prior to use.*

1.6 *This international standard was developed in accordance with internationally recognized principles on standardization established in the Decision on Principles for the Development of International Standards, Guides and Recommendations issued by the World Trade Organization Technical Barriers to Trade (TBT) Committee.*

2. Referenced Documents

2.1 ASTM Standards:³

- D695 Test Method for Compressive Properties of Rigid Plastics
- D883 Terminology Relating to Plastics
- D3410/D3410M Test Method for Compressive Properties of Polymer Matrix Composite Materials with Unsupported Gage Section by Shear Loading
- D3878 Terminology for Composite Materials
- D5229/D5229M Test Method for Moisture Absorption Properties and Equilibrium Conditioning of Polymer Matrix Composite Materials
- D5379/D5379M Test Method for Shear Properties of Composite Materials by the V-Notched Beam Method
- D5467/D5467M Test Method for Compressive Properties of Unidirectional Polymer Matrix Composite Materials Using a Sandwich Beam
- D5687/D5687M Guide for Preparation of Flat Composite Panels with Processing Guidelines for Specimen Preparation

³ For referenced ASTM standards, visit the ASTM website, www.astm.org, or contact ASTM Customer Service at service@astm.org. For *Annual Book of ASTM Standards* volume information, refer to the standard's Document Summary page on the ASTM website.

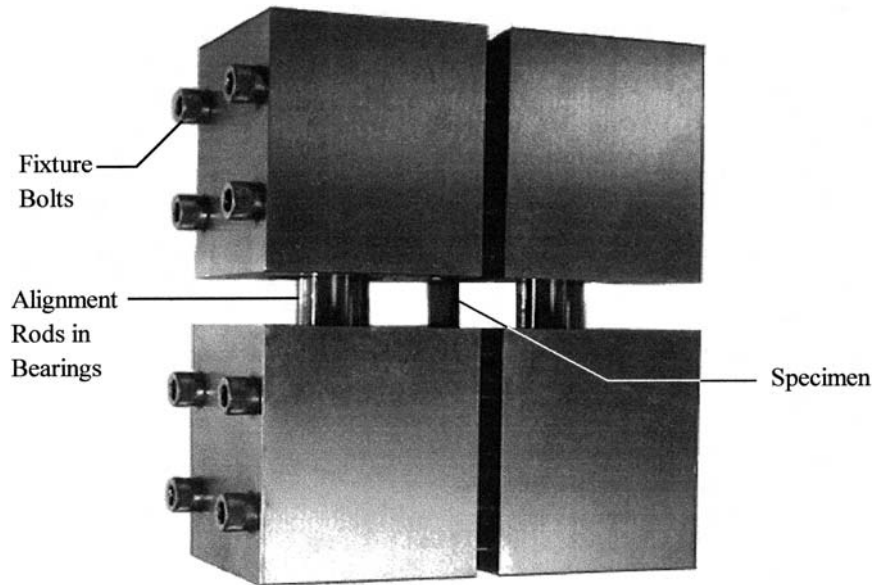

FIG. 1 Photograph of a Typical Combined Loading Compression (CLC) Test Fixture

- E4 Practices for Force Verification of Testing Machines
 - E6 Terminology Relating to Methods of Mechanical Testing
 - E122 Practice for Calculating Sample Size to Estimate, With Specified Precision, the Average for a Characteristic of a Lot or Process
 - E132 Test Method for Poisson's Ratio at Room Temperature
 - E177 Practice for Use of the Terms Precision and Bias in ASTM Test Methods
 - E456 Terminology Relating to Quality and Statistics
 - E691 Practice for Conducting an Interlaboratory Study to Determine the Precision of a Test Method
 - E1309 Guide for Identification of Fiber-Reinforced Polymer-Matrix Composite Materials in Databases (Withdrawn 2015)⁴
 - E1434 Guide for Recording Mechanical Test Data of Fiber-Reinforced Composite Materials in Databases (Withdrawn 2015)⁴
 - E1471 Guide for Identification of Fibers, Fillers, and Core Materials in Computerized Material Property Databases (Withdrawn 2015)⁴
- 2.2 *ASTM Adjunct:*
 Combined Loading Compression (CLC) Test Fixture, D 6641/D6641M⁵

3. Terminology

3.1 *Definitions*—Terminology D3878 defines terms relating to high-modulus fibers and their composites. Terminology D883 defines terms relating to plastics. Terminology E6 defines terms relating to mechanical testing. Terminology E456 and Practice E177 define terms relating to statistics. In the event of

⁴The last approved version of this historical standard is referenced on www.astm.org.

⁵A detailed drawing for the fabrication of the test fixture shown in Figs. 1 and 2 is available from ASTM Headquarters, www.astm.org. Order Adjunct No. ADJD6641-E-PDF.

a conflict between terms, Terminology D3878 shall have precedence over the other Terminology standards.

3.2 *Symbols:* A —cross-sectional area of specimen in gage section

B_y —face-to-face percent bending in specimen

CV —sample coefficient of variation, in percent

E^c —laminar compressive modulus

F^{cu} —laminar ultimate compressive strength

F^{cr} —Euler buckling stress

G_{xz} —through-thickness shear modulus of laminar

h —specimen thickness

I —moment of inertia of specimen cross section

l_g —specimen gage length

n —number of specimens

P —load carried by test specimen

P^f —load carried by test specimen at failure

s —as used in a lay-up code, denotes that the preceding ply description for the laminar is repeated symmetrically about its midplane

s_{n-1} —sample standard deviation

w —specimen gage width

\bar{x} —sample mean (average)

x_i —measured or derived property

ϵ —indicated normal strain from strain transducer

ϵ_x —laminar axial strain

ϵ_y —laminar in-plane transverse strain

ϵ_1, ϵ_2 —strain gage readings

ν_{xy}^c —compressive Poisson's ratio

4. Summary of Test Method

4.1 A test fixture such as that shown in Figs. 1 and 2, or any comparable fixture, can be used to test the untabbed (Procedure A) or tabbed (Procedure B) straight-sided composite specimen of rectangular cross section shown schematically in Fig. 3. A typical specimen is 140 mm [5.5 in.] long and 13 mm [0.5 in.] wide, having an unsupported (gage) length of 13 mm [0.5 in.]

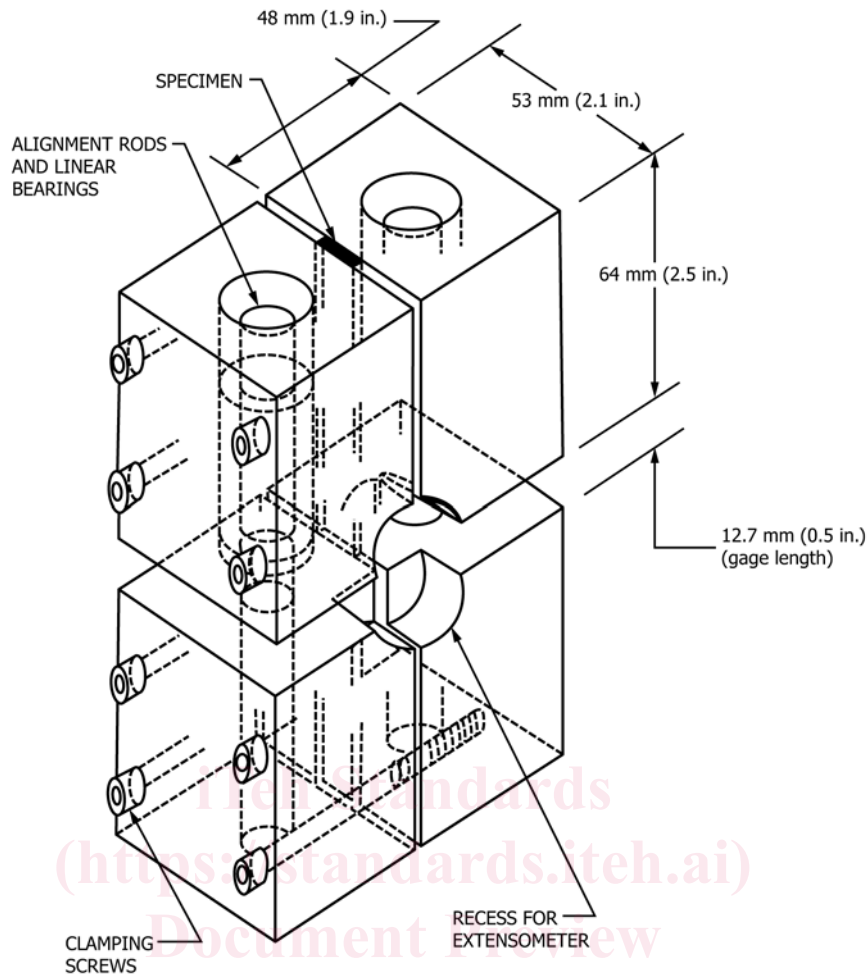

Note: Using standard M6x1 (1/4-28 UNF) screws, the bolt torque required to test most composite material specimens successfully is typically between 2.5 and 3.0 N-m [20 and 25 in.-lb.].

FIG. 2 Dimensioned Sketch of a Typical Combined Loading Compression (CLC) Test Fixture

when installed in the fixture. A gage length greater or less than 13 mm is acceptable, subject to specimen buckling considerations (see 8.2). The 13-mm [0.5 in.] gage length provides sufficient space to install bonded strain gages when they are required. The fixture, which subjects the specimen to combined end- and shear-loading, is itself loaded in compression between flat platens in a universal testing machine. Load-strain data are collected until failure occurs (or until a specified strain level is achieved if only compressive modulus or Poisson's ratio, or both, are to be determined, and not the complete stress-strain curve to failure).

5. Significance and Use

5.1 This test method is designed to produce compressive property data for material specifications, research and development, quality assurance, and structural design and analysis. When tabbed (Procedure B) specimens, typically unidirectional composites, are tested, the CLC test method (combined shear end loading) has similarities to Test Methods D3410/D3410M (shear loading) and D695 (end loading). When testing lower strength materials such that untabbed CLC specimens can be used (Procedure A), the benefits of combined loading become particularly prominent. It may not be possible

to successfully test untabbed specimens of these same materials using either of the other two methods. When specific laminates are tested (primarily of the [90/0]_{ns} family, although other laminates containing at least one 0° ply can be used), the CLC data are frequently used to “back out” 0° ply strength, using lamination theory to calculate a 0° unidirectional lamina strength (1, 2). Factors that influence the compressive response include: type of material, methods of material preparation and lay-up, specimen stacking sequence, specimen preparation, specimen conditioning, environment of testing, speed of testing, time at temperature, void content, and volume percent reinforcement. Composite properties in the test direction that may be obtained from this test method include:

- 5.1.1 Ultimate compressive strength,
- 5.1.2 Ultimate compressive strain,
- 5.1.3 Compressive (linear or chord) modulus of elasticity, and
- 5.1.4 Poisson's ratio in compression.

6. Interferences

6.1 Because of partial end loading of the specimen in this test method, it is important that the ends of the specimen be machined flat, parallel to each other, and perpendicular to the

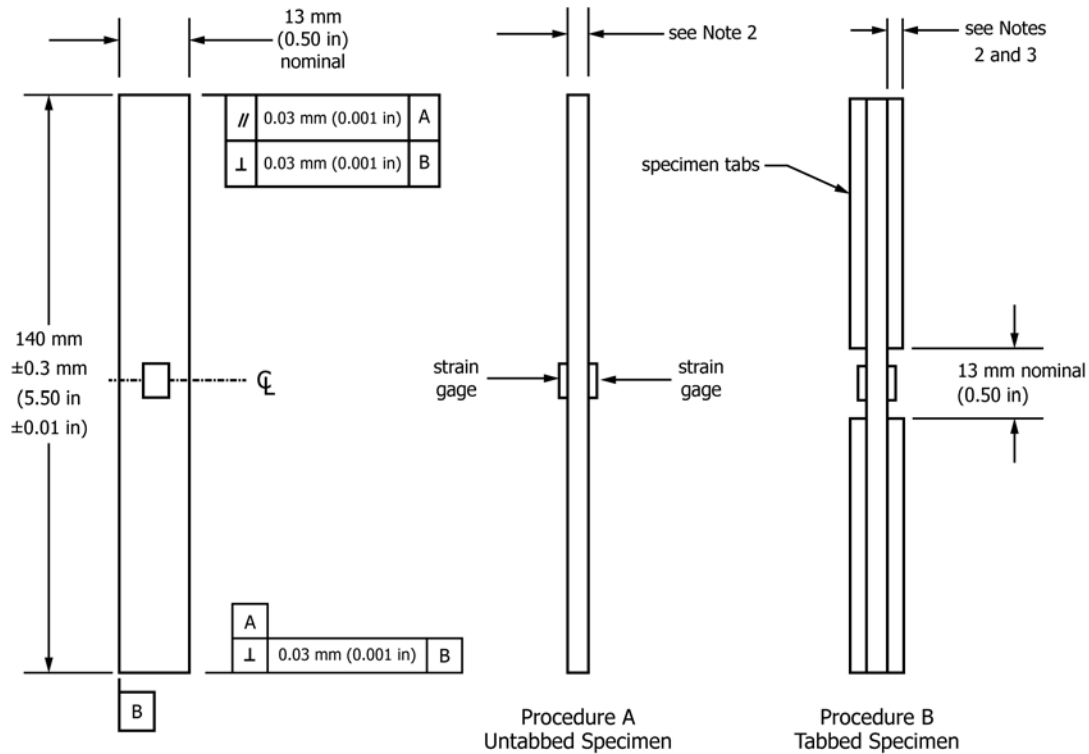

(1) The specimen ends must be parallel to each other within 0.03 mm [0.001 in.] and also perpendicular to the longitudinal axis of the specimen within 0.03 [0.001 in.], for both Procedures A and B.

(2) Nominal specimen and tabbing thickness can be varied, but must be uniform. Thickness irregularities (for example, thickness taper or surface imperfections) shall not exceed 0.03 mm [0.001 in.] across the specimen or tab width or 0.06 mm [0.002 in.] along the specimen grip length or tab length.

(3) Tabs are typically square-ended and on the order of 1.6 mm [0.06 in.] thick, but thickness can be varied as required, as discussed in 8.2.

(4) The faces of the specimen may be lapped slightly to remove any local surface imperfections and irregularities, thus providing flatter surfaces for more uniform gripping by the fixture.

FIG. 3 Typical Test Specimen Configuration

long axis of the coupon (see Fig. 3), just as for Test Method D695. Improper preparation may result in premature end crushing of the specimen during loading, excessive induced bending, or buckling, potentially invalidating the test.

6.2 Erroneously low laminate compressive strengths will be produced as a result of Euler column buckling if the specimen is too thin in relation to the gage length (see 8.2). In such cases, the specimen thickness must be increased or the gage length reduced. A practical limit on reducing gage length is maintaining adequate space in which to attach strain gages, if required. A gage length of at least about 9 mm [0.35 in.] is typically required for this purpose. Bending or buckling, or both, can usually only be detected by the use of back-to-back strain gages mounted on the faces of the specimen (3). Bending and buckling are not visually obvious during the test, or from an examination of the specimen failure mode.

6.3 For a valid test, final failure of the specimen must occur within the gage section. Which failure modes are deemed acceptable will be governed by the particular material, configuration, and application (see 12.1).

6.4 Untabbed (Procedure A) specimens of continuous-fiber-reinforced laminates having more than 50 % axially oriented

(0°) plies may require higher than acceptable fixture clamping forces to prevent end crushing. Excessive clamping forces induce at the ends of the gage section local stress concentrations that may produce erroneously low strength results (see 11.2.7). In such cases, the specimen must be tabbed (Procedure B).

6.5 If the outermost plies of a laminate are oriented at 0°, the local stress concentrations at the ends of the specimen gage section may lead to premature failure of these primary load-bearing plies, producing erroneously low laminate strength results. This is particularly true for specimens with low numbers of plies, since then the outer plies represent a significant fraction of the total number of plies (1).

6.6 The compressive strength and stiffness properties of unidirectional composites as well as all laminate configurations may be determined using this test method, subject to some limitations (1). One limitation is that the fixture clamping forces induced by the applied bolt torques required to successfully fail the composite before specimen end crushing must not induce significant stress concentrations at the ends of the gage section (4). Such stress concentrations will degrade the measured compressive strength. For example, testing an untabbed

high-strength unidirectional composite is likely to be unsuccessful because of the excessive clamping forces required to prevent specimen end crushing, whereas a lower strength unidirectional composite may be successfully tested using acceptable clamping forces. The use of a tabbed specimen to increase the bearing area at the specimen ends is then necessary (1, 5). An untabbed thickness-tapered specimen, although nonstandard, has also been used to successfully test high-strength unidirectional composites (5).

6.7 In multidirectional laminates, edge effects can affect the measured strength and modulus of the laminate.

7. Apparatus and Supplies

7.1 *Micrometers and Calipers*—A micrometer having a suitable-size diameter ball-interface on irregular surfaces such as the bag-side of a laminate, and a flat anvil interface on machined edges or very smooth tooled surfaces, shall be used. A caliper of suitable size can also be used on machined edges or very smooth tooled surfaces. The accuracy of these instruments shall be suitable for reading to within 1 % of the sample length, width and thickness. For typical specimen geometries, an instrument with an accuracy of $\pm 2.5 \mu\text{m}$ [± 0.0001 in.] is desirable for thickness and width measurement, while an instrument with an accuracy of $\pm 25 \mu\text{m}$ [± 0.001 in.] is desirable for length measurements.

7.2 *Torque Wrench*—Calibrated within the torque range required.

7.3 *Testing Machine*—A calibrated testing machine shall be used which can be operated at constant crosshead speed over the specified range. The test machine mechanism shall be essentially free from inertial lag at the crosshead speeds specified. The machine shall be equipped with an appropriate force-measuring device (for example, a load cell). The accuracy of the test machine shall be in accordance with Practices E4.

7.4 *Conditioning Chamber*—When conditioning materials in other than ambient laboratory environments, a temperature-/moisture-level controlled environmental conditioning chamber is required that shall be capable of maintaining the required relative temperature to within $\pm 3^\circ\text{C}$ [$\pm 5^\circ\text{F}$] and the required relative vapor level to within $\pm 5\%$. Chamber conditions shall be monitored either on an automated continuous basis or on a manual basis at regular intervals.

7.5 *Environmental Chamber*—A chamber capable of enclosing the test fixture and specimen while they are mounted in the testing machine, and capable of achieving the specified heating/cooling rates, test temperatures, and environments, shall be used when nonambient conditions are required during testing. This chamber shall be capable of maintaining the gage section of the test specimen within $\pm 3^\circ\text{C}$ [$\pm 5^\circ\text{F}$] of the required test temperature during the mechanical test. In addition, the chamber may have to be capable of maintaining environmental conditions such as fluid exposure or relative humidity during the test.

7.6 *Compression Fixture*—A test fixture such as that shown in Figs. 1 and 2, or a comparable fixture, shall be used. The

fixture shown introduces a controllable ratio of end loading to shear loading into the specimen, by controlling the torque applied to the clamping screws.

7.7 *Strain-Indicating Device*—Longitudinal strain shall be simultaneously measured on opposite faces of the specimen to allow for a correction as a result of any bending of the specimen, and to enable detection of Euler (column) buckling. Back-to-back strain measurement shall be made for all five specimens when the minimum number of specimens allowed by this test method are tested. If more than five specimens are to be tested, then a single strain-indicating device may be used for the number of specimens greater than the five, provided the total number of specimens are tested in a single test fixture and load frame throughout the tests, that no modifications to the specimens or test procedure are made throughout the duration of the tests, and provided the bending requirement (see 12.3 and 12.4) is met for the first five specimens. If these conditions are not met, then all specimens must be instrumented with back-to-back devices. When Poisson's ratio is to be determined, the specimen shall be instrumented to measure strain in the lateral direction using the same type of transducer. The same type of strain transducer shall be used for all strain measurements on any single coupon. Strain gages are recommended because of the short gage length of the specimen. Attachment of the strain-indicating device to the coupon shall not cause damage to the specimen surface.

7.8 *Data Acquisition Equipment*—Equipment capable of recording force and strain data is required.

8. Sampling and Test Specimens

8.1 *Sampling*—Test at least five specimens per test condition unless valid results can be gained through the use of fewer specimens, such as in the case of a designed experiment. For statistically significant data, the procedures outlined in Practice E122 should be consulted. The method of sampling shall be reported.

8.2 *Geometry*—The test specimen is an untabbed (Procedure A) or tabbed (Procedure B) rectangular strip of the composite to be tested, as shown in Fig. 3. A guide to preparation of flat composite panels, with processing guidelines for specimen preparation, is presented in Guide D5687/D5687M. Specimen dimensions and tolerances must be in compliance with the requirements of Fig. 3. As noted also in 6.6, for materials with a sufficiently high compressive strength in the direction of loading, end crushing or an untabbed specimen cannot be prevented by increasing fixture clamping force alone. It then becomes necessary to use tabs, to increase the load-bearing area at the specimen ends. While tapered tabs would be potentially beneficial in reducing stress concentrations in the specimen at the tab ends, they increase the effective unsupported length (gage length) of the specimen, increasing the possibility of inducing specimen buckling. Thus, untapered (square-ended) tabs are recommended. For many polymer-matrix composites, glass fabric/epoxy tabs have been found to perform well (1, 4). This material has a favorable combination of compliance, shear strength and toughness. Note that tabs having a low stiffness, yet sufficiently strong to transmit the

induced forces, are desired. Thus, tabs of the same material as the specimen are normally not desired, contrary to common beliefs (6). For specimen thicknesses on the order of 2.5 mm [0.10 in.] thick or less, tabs on the order of 1.6 mm [0.06 in.] thick have been found to be adequate (1, 4). For thicker specimens, thicker tabs may be required, a tab thickness limit being reached when the tab adhesive is no longer able to transfer the induced shear forces. In this case, the practical solution is to reduce the specimen thickness. If axial strain is to be measured (for example, to monitor specimen bending, to determine the axial compressive modulus, or to obtain a stress-strain curve), two single-element axial strain gages or similar transducers are typically mounted back-to-back on the faces of the specimen, in the center of the gage section, as shown in Fig. 3 (see also Section 12). If in-plane transverse strain is also to be measured (for example, to calculate the in-plane compressive Poisson's ratio), an additional single-element strain gage oriented in the transverse direction on one face of the specimen may be used. Alternatively, one or more strain gage rosettes may be used.

8.2.1 *Specimen Width*—The nominal specimen width shall be 13 mm [0.50 in.]. However, other widths may be used. For example, the fixture shown in Figs. 1 and 2 can accommodate specimens up to a maximum width of 30 mm [1.2 in.]. In order to maintain a representative volume of material within the gage section, specimens narrower than 13 mm [0.50 in.] are not typically used. It is sometimes desirable to use specimens wider than nominal, for example, if the material architecture is coarse (as for a coarse-weave fabric), again to maintain a representative gage section volume of material being tested.

8.2.2 *Specimen Thickness*—Although no specific specimen thickness is required, some limitations exist. The thickness must be sufficient to preclude Euler column buckling of the specimen. Eq 1 may be used to estimate the minimum thickness to be used for strength determinations (see also Test Method D3410/D3410M). As indicated in Eq 1, the minimum specimen thickness required depends on a number of factors in addition to gage length (1, 4).

$$h \geq \frac{l_g}{0.9069 \sqrt{\left(1 - \frac{1.2F^{cu}}{G_{xz}}\right) \left(\frac{E^f}{F^{cu}}\right)}} \quad (1)$$

where:

- h = specimen thickness, mm [in.],
- l_g = length of gage section, mm [in.],
- F^{cu} = expected ultimate compressive strength, MPa [psi],
- E^f = expected flexural modulus, MPa [psi], and
- G_{xz} = through-the-thickness (interlaminar) shear modulus, MPa [psi].

NOTE 2—Eq 1 is derived from the following expression for the Euler buckling stress for a pin-ended column of length l_g (an assumption which is strictly not valid for the specimen gage length l_g), modified for shear deformation effects. The E^f in Eq 1 and Eq 2 is the flexural modulus of the specimen. For the intended purpose, the approximation of using the compressive modulus E^c in place of the flexural modulus E^f may be valid.

8.2.2.1 Eq 1 may be rewritten in the form of Eq 2 (7).

$$F_{cr} = \frac{\pi^2 E^f}{\frac{l_g^2 A}{I} + 1.2\pi^2 \frac{E^f}{G_{xz}}} \quad (2)$$

where:

- F_{cr} = predicted Euler buckling stress, MPa [psi],
- A = specimen cross-sectional area, mm² [in.²], and
- I = minimum moment of inertia of specimen cross section, mm⁴ [in.⁴].

8.2.2.2 Eq 2 can be used to estimate the applied stress, F_{cr} , on the test specimen at which Euler buckling is predicted to occur for the specific specimen configuration of interest. Practical experience has shown that Eq 1 and Eq 2 are reliable for conventional fiber/polymer matrix composites, and that as a general guide, keeping the predicted value F_{cr} of buckling stress at least 30 % above the expected compressive strength is usually sufficient (1, 4).⁶ Other composites may require different percentages.

8.2.2.3 The through-the-thickness (interlaminar) shear modulus, G_{xz} , as required in Eq 1 and 2, can be measured, for example, by using Test Method D5379/D5379M. If G_{xz} is not available in the form of experimental data, assuming value of G_{xz} of approximately 4 GPa [0.60 Msi] is a reasonable estimate for most polymer matrix composite materials tested at room temperature (4). In any case, this is offered only as an estimate, to serve as a starting point when designing a test specimen of a material with an unknown G_{xz} . Also, this assumed value may not be reasonable for configurations such as stitched laminates or 3D woven composites, in which case it will be necessary to measure G_{xz} directly. The absence of specimen buckling must eventually be verified experimentally. The specimen can be thinner if only modulus is being determined, as the required applied force may then be significantly lower than the buckling force. There is no specific upper limit on specimen thickness. For Procedure A (untabbed specimens), one practical limitation is the increasing difficulty of applying a uniform pressure over the ends of a specimen of progressively larger cross-sectional area. Another is the need to apply increasing clamping forces to prevent end crushing as the specimen becomes thicker (by maintaining the desired ratio of end loading to shear loading). As discussed in 6.4, the induced stress concentrations in the specimen by the test fixture increase as the clamping force increases. Note that increasing the width of the specimen does not alleviate this condition. For Procedure B (tabbed specimens), the tab thickness must be increased as specimen thickness increases, to prevent end crushing. The limit on specimen thickness is when the tab adhesive can no longer transmit the forces on the tab ends into the specimen via shear through the adhesive.

9. Calibration

9.1 The accuracy of all measuring equipment shall have certified calibrations that are current at the time of use of the equipment.

10. Conditioning

10.1 *Standard Conditioning Procedure*—Unless a different environment is specified as part of the experiment, condition

⁶ Supporting data have been filed at ASTM International Headquarters and may be obtained by requesting Research Report RR:D30-1007. Contact ASTM Customer Service at service@astm.org.