



Designation: **D5652—15** **D5652 – 21**

Standard Test Methods for Single-Bolt Connections in Wood and Wood-Based Products¹

This standard is issued under the fixed designation D5652; the number immediately following the designation indicates the year of original adoption or, in the case of revision, the year of last revision. A number in parentheses indicates the year of last reappraisal. A superscript epsilon (ϵ) indicates an editorial change since the last revision or reappraisal.

1. Scope

1.1 These test methods cover procedures for evaluating the strength and stiffness of single-bolt connections in wood or wood-based products when subjected to short-term static loading. These test methods serve as a basis for determining the effects of various factors on the strength and stiffness of the connection. Long-term loading and creep displacement characteristics are outside the scope of this protocol.

1.2 These test methods are intended for situations employing a smooth shank bolt with a constant diameter.

1.3 The values stated in inch-pound units are to be regarded as the standard. The SI units values given in parentheses are for information only—mathematical conversions to SI units that are provided for information only and are not considered standard.

1.4 *This standard does not purport to address all of the safety concerns, if any, associated with its use. It is the responsibility of the user of this standard to establish appropriate safety, health, and environmental practices and determine the applicability of regulatory limitations prior to use.*

1.5 *This international standard was developed in accordance with internationally recognized principles on standardization established in the Decision on Principles for the Development of International Standards, Guides and Recommendations issued by the World Trade Organization Technical Barriers to Trade (TBT) Committee.*

2. Referenced Documents

2.1 ASTM Standards:²

[D2395 Test Methods for Density and Specific Gravity \(Relative Density\) of Wood and Wood-Based Materials](#)

[D2915 Practice for Sampling and Data-Analysis for Structural Wood and Wood-Based Products](#)

[D4442 Test Methods for Direct Moisture Content Measurement of Wood and Wood-Based Materials](#)

[E4 Practices for Force Verification of Testing Machines](#)

[E2309/E2309M Practices for Verification of Displacement Measuring Systems and Devices Used in Material Testing Machines](#)

[F606/F606M Test Methods for Determining the Mechanical Properties of Externally and Internally Threaded Fasteners, Washers, Direct Tension Indicators, and Rivets](#)

2.2 Federal Specification:

[Fed. Spec. FF-W-92 for Washers, Metal, Flat \(Plain\)](#)

2.3 Other Standards:

[NDS ANSI/AWC National Design Specification for Wood Construction](#)

¹ These test methods are under the jurisdiction of ASTM Committee [D07](#) on Wood and are the direct responsibility of Subcommittee [D07.05](#) on Wood Assemblies. Current edition approved Dec. 1, 2015; March 15, 2021. Published February 2016; April 2021. Originally approved in 1995. Last previous edition approved in 2013 as [D5652 – 95 \(2013\)](#); [D5652 – 15](#). DOI: [10.1520/D5652-15.10.1520/D5652-21](#).

² For referenced ASTM standards, visit the ASTM website, [www.astm.org](#), or contact ASTM Customer Service at [service@astm.org](#). For *Annual Book of ASTM Standards* volume information, refer to the standard's Document Summary page on the ASTM website.

3. Summary of Test Methods

3.1 Specimens consisting of at least one wood or wood-based member fastened with one bolt to at least one other member of any material are evaluated for capacity to resist compressive or tensile forces applied at a constant speed of displacement with a suitable testing machine. The slip, or displacement, of the connection at various intervals of loading is measured. Supplementary physical properties of the wood or wood-based members are also determined.

4. Significance and Use

4.1 Connections are one of the most important components in wood construction. While the strength of metal bolts and of wood or wood-based products are ascertainable, a full evaluation of the performance of the combination is only possible through the testing of a complete connection assembly. Such variables as member thickness, member width, end and edge distances, type of bolt, fabrication tolerances, moisture content of the wood or wood-based product, preservative or fire-retardant treatment of the wood or wood-based product, species of wood, and/or material type and orientation of wood-based material may affect connection behavior. In order to develop design criteria for established bolt types as well as those under development, the effect of these variables on connection strength and stiffness must be known. The tests described herein permit the observation of data on the strength and stiffness of wood or wood-based connections, or both, under the influence of any or all of these factors.

5. Apparatus

5.1 *Testing Machine*—Any suitable testing machine capable of operation at a constant movable crosshead speed and having an accuracy of $\pm 1\%$ when calibrated in accordance with Practices E4.

5.2 *Spherical Bearing Block*, for compressive loading of specimens.

5.3 *Grips*—Gripping devices capable of attaching the specimen to the stationary and moving heads of the testing machine in such a way as to ensure true axial tensile loads.

5.4 *Displacement Measurement Devices*—At least two displacement measurement devices for measuring the slip between connection members during load application. These devices shall be capable of at least a Class B rating when evaluated in accordance with Practice E2309/E2309M.

6. Sampling

6.1 Sampling shall provide for selection of representative test specimens that are appropriate to the objectives of the testing program.

6.2 Sample size shall be estimated in accordance with the procedures of Method D2915; however, a minimum of ten tests shall be conducted to evaluate each connection configuration or variable. See Note 1 for guidance in this respect.

NOTE 1—The precision required, and thus, the manner of sampling and the number of tests, depend upon the specific test objectives. No specific criteria can therefore be established. General experience indicates that the coefficients of variation from tests on connections range from approximately 15 to 30%. Depending upon the objectives of the test, it is important to understand the different failure modes that might occur between specimens for a given test configuration, the variation associated with those modes, and their impact upon variability. For those configurations that result in multiple modes of failure, it may be necessary to conduct exploratory testing to establish the expected variability.

7. Test Specimens

7.1 *Material Selection:*

7.1.1 *Wood*—Select wood members, the material, and position the bolt in them the members in such a way that the results are not affected by knots, cross grain, or other natural or manufacturing characteristics unless the purpose of the test methods is to evaluate the effects of such growth characteristics. When the effects of manufacturing and growth characteristics are not being evaluated, wood members shall be essentially clear and straight-grained. Unless otherwise specified to satisfy the test objectives, the wood members shall be selected to target an average oven-dry specific gravity representative of the material to be evaluated.

7.1.2 *Wood-Based Material*—For wood-based products, such as structural composite lumber or wood plastic composites, the

specimen grade, density, thickness and other manufactured characteristics shall be representative of the material to be evaluated. Since the connection properties of a wood-based product typically vary with the cross-sectional product orientation, the bolt shall be positioned in the cross-sectional orientation to be evaluated and that orientation shall be recorded. Unless the purpose of the study is to evaluate a product's known strength reducing characteristics, bolts shall be randomly positioned into the member without further bias to consider strength reducing characteristics.

7.1.3 Non-Uniform Cross-Sections—Cross-sections selected for testing shall be representative of the product to be evaluated. Some wood-based products are made with a hollow extrusion, significant density gradient profile, or other non-uniformity that has the potential to impact the test results. If the wood-based product to be tested has a non-uniform cross-section, then the related product characteristics and the bolt position shall be reported in detail.

7.1.4 Steel—Steel members used as part of the test program shall have their nominal thickness and grade chosen to satisfy the experimental objectives and be recorded.

7.1.5 Bolts—The nominal bolt diameter and grade shall be chosen to satisfy the experimental objectives and be recorded.

NOTE 2—For product evaluation purposes, it may be desirable to select materials that conservatively represent the range of permitted applications. For example, using the lowest permitted specific gravity of wood, the lowest grade of wood-based material, the worst-case non-uniform cross-section, etc. These constraints should be considered on a case-by-case basis.

7.2 Connection Assembly: Primary Tests:

~~7.2.1 Connection assemblies shall consist of three members as shown in Primary tests shall **Figs. 1-3** except where specific data on two- or multiple-member connections are being sought. Select the width, length, and thickness of the members with consideration of required edge and end distances. Member dimensions shall be representative of the test objectives or as required to target specific yield or failure modes.~~ be made on connections loaded parallel to the grain and perpendicular to the grain of members.

7.2.1.1 Parallel to the grain tests shall be conducted with the grain or strength-axis of the main and of the side members parallel to the direction of the load.

7.2.1.2 Perpendicular to the grain tests shall be conducted as follows:

(1) with the grain or strength-axis of the main member perpendicular and the side members perpendicular to the direction of the load,

(2) with the grain or strength-axis of the main member parallel and the side members perpendicular to the direction of the load,
or

(3) with the grain or strength-axis of the main member perpendicular and the side members parallel to the direction of the load.

7.2.2 Primary tests shall be made by applying compressive or tensile loads to the connection assembly as required; however, application of tensile load is preferred.

~~7.2.3 For members loaded parallel to grain, the minimum end distance shall be seven bolt diameters for tension loading (Connection assemblies for primary tests shall consist of three members as shown in **Fig. 1**) and four bolt diameters for compression loading (, **Fig. 2**), unless the effect of various end distances is to be studied. For members loaded perpendicular to grain (, or **Fig. 3**), the minimum unloaded edge distance shall be 1.5 bolt diameters and the. Where specific data on two-member or multiple-member connections are being sought, see **7.3** minimum loaded edge distance shall be four diameters, unless the effect of various edge distances is to be studied.~~

7.2.3.1 Select the width, length, and thickness of the members considering the required edge and end distances. Member dimensions shall be representative of the test objectives or as required to target specific yield modes or failure modes.

7.2.3.2 For members loaded parallel to the grain, the end distance shall be seven times the bolt diameter for tensile loading (**Fig. 1**) and four times the bolt diameter for compressive loading (**Fig. 2**), unless the effect of various end distances is to be studied (see **7.3**).

7.2.3.3 For members loaded perpendicular to the grain (**Fig. 3**), the unloaded edge distance shall be 1.5 times the bolt diameter and the loaded edge distance shall be four times the bolt diameter, unless the effect of various edge distances is to be studied (see **7.3**).

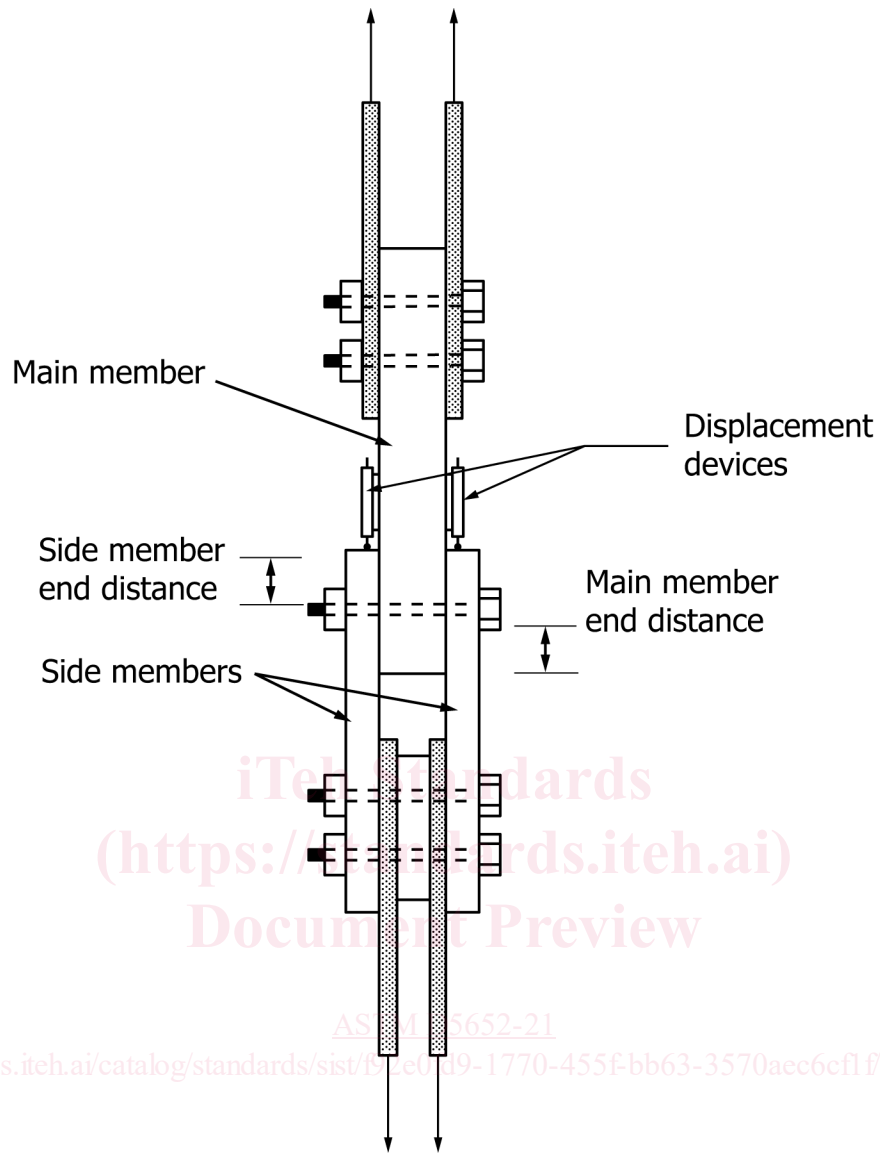

FIG. 1 Assembly for Testing Single-Bolt Connections Parallel to Grain in Tension

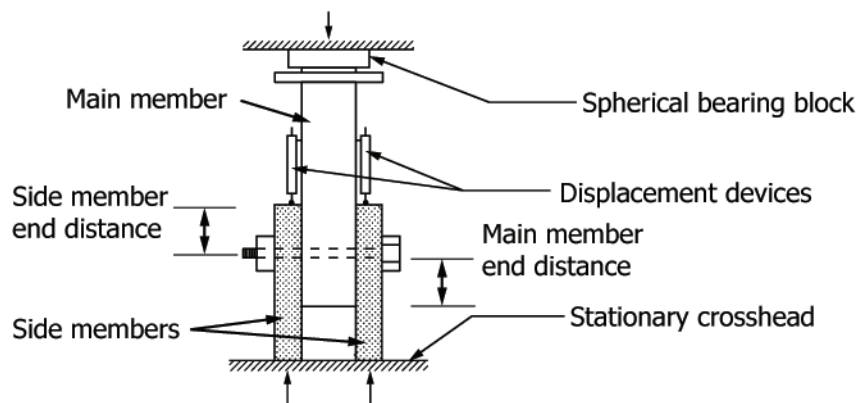

FIG. 2 Assembly for Testing Single-Bolt Connections Parallel to Grain in Compression

7.2.4 Unless other bolt-hole diameters are required to satisfy the purposes of the investigation, the bolt-hole Bolt-hole diameter shall be $\frac{1}{16}$ in. (1.6 mm) larger than the nominal bolt diameter for main and side members. Alternative bolt-hole diameters, if used, shall be recorded.

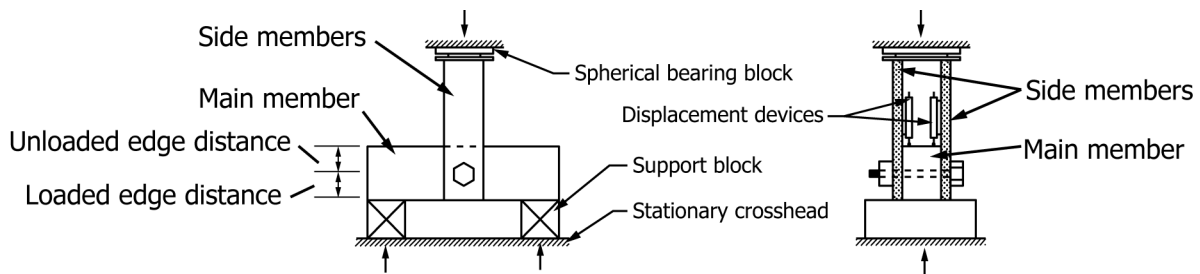

FIG. 3 Assembly for Testing Single-Bolt Connections Perpendicular to Grain in Compression

7.2.4.1 Bolt-holes shall be precisely bored perpendicular to the surface, so that the surface of the hole is smooth and uniform to ensure good bearing of the bolt. Holes shall be drilled after members are conditioned unless the purpose of the test is to study the effect of shrinkage on the performance of bolted connections.

7.2.5 Bolts shall be of sufficient length to penetrate all members. The standard configuration shall be to test without having any member bear on the bolt threads. Inclusion of threads within the bearing surfaces shall be permitted provided that thread type and length of threaded bearing are reported.

7.2.6 Place heavy round washers conforming to Fed. Spec. FF-W-92 for washers, metal, flat (plain), and hereafter referred to as a standard washer, between wood or wood-based side members and bolt head and nut. Bring abutting faces of connection members into normally installed contact; then back off the nut and retighten to “finger tightness”-tightness.”

7.2.6 Primary tests shall be made on connections loaded parallel to and perpendicular to the grain of wood members. Perpendicular to the grain tests shall be conducted as follows:

7.2.6.1 With the grain or strength-axis of the main member perpendicular and the side members perpendicular to the direction of the load;

7.2.6.2 With the grain or strength-axis of the main member parallel and the side members perpendicular to the direction of the load; or

7.2.6.3 With the grain or strength-axis of the main member perpendicular and the side members parallel to the direction of the load.

7.2.7 Primary tests shall be made by applying compressive or tensile loads as required; however, application of tensile load is preferred.

7.2.8 When required by the investigation, conduct additional tests to provide information on the items stated in 7.2.8.1 and 7.2.8.10. In such tests, use a method of matching the material in corresponding members to prevent masking of differences in specific gravity, rate of growth, or other factors:

7.2.8.1 To establish the effect of bearing area and length to diameter (L/d) relationship;

7.2.8.2 To determine the effect of variations in main member thickness;

7.2.8.3 To determine the effect of variations in side member thickness;

7.2.8.4 To determine the effect of angle of load to grain of the wood or strength axis of a wood-based material;

7.2.8.5 To establish minimum end distances required for each size of bolt and the effect of variations in end distances;

7.2.8.6 To establish minimum edge distance and the effect of variations in edge distance;

7.2.8.7 To determine the effect of moisture content of the wood or wood-based product;

7.2.8.8 To evaluate wood-based material cross-sectional orientations;