



Designation: D6416/D6416M – 16^{ε1}

Standard Test Method for Two-Dimensional Flexural Properties of Simply Supported Sandwich Composite Plates Subjected to a Distributed Load¹

This standard is issued under the fixed designation D6416/D6416M; the number immediately following the designation indicates the year of original adoption or, in the case of revision, the year of last revision. A number in parentheses indicates the year of last reapproval. A superscript epsilon (ϵ) indicates an editorial change since the last revision or reapproval.

^{ε1} NOTE—Editorial corrections were made to the adjunct information in April 2021.

1. Scope

1.1 This test method determines the two-dimensional flexural properties of sandwich composite plates subjected to a distributed load. The test fixture uses a relatively large square panel sample which is simply supported all around and has the distributed load provided by a water-filled bladder. This type of loading differs from the procedure of Test Method C393, where concentrated loads induce one-dimensional, simple bending in beam specimens.

1.2 This test method is applicable to composite structures of the sandwich type which involve a relatively thick layer of core material bonded on both faces with an adhesive to thin-face sheets composed of a denser, higher-modulus material, typically, a polymer matrix reinforced with high-modulus fibers.

1.3 The values stated in either SI units or inch-pound units are to be regarded separately as standard. Within the text the inch-pound units are shown in brackets. The values stated in each system are not exact equivalents; therefore, each system must be used independently of the other. Combining values from the two systems may result in nonconformance with the standard.

1.4 *This standard does not purport to address all of the safety concerns, if any, associated with its use. It is the responsibility of the user of this standard to establish appropriate safety, health, and environmental practices and determine the applicability of regulatory limitations prior to use.*

1.5 *This international standard was developed in accordance with internationally recognized principles on standardization established in the Decision on Principles for the Development of International Standards, Guides and Recom-*

mendations issued by the World Trade Organization Technical Barriers to Trade (TBT) Committee.

2. Referenced Documents

2.1 ASTM Standards:²

- C365/C365M Test Method for Flatwise Compressive Properties of Sandwich Cores
 - C393 Test Method for Core Shear Properties of Sandwich Constructions by Beam Flexure
 - D792 Test Methods for Density and Specific Gravity (Relative Density) of Plastics by Displacement
 - D2584 Test Method for Ignition Loss of Cured Reinforced Resins
 - D2734 Test Methods for Void Content of Reinforced Plastics
 - D3171 Test Methods for Constituent Content of Composite Materials
 - D3878 Terminology for Composite Materials
 - E4 Practices for Force Verification of Testing Machines
 - E6 Terminology Relating to Methods of Mechanical Testing
 - E251 Test Methods for Performance Characteristics of Metallic Bonded Resistance Strain Gages
 - E1237 Guide for Installing Bonded Resistance Strain Gages
- 2.2 *ASTM Adjunct:*
Sandwich Plate Test Fixture and Hydromat Pressure Bladder, ASTM D6416/D6416M³

3. Terminology

3.1 Terminology D3878 defines terms relating to high-modulus fibers and their composites, as well as terms relating to sandwich constructions. Terminology E6 defines terms relating to mechanical testing. In the event of a conflict

¹ This test method is under the jurisdiction of ASTM Committee D30 on Composite Materials and is the direct responsibility of Subcommittee D30.09 on Sandwich Construction.

Current edition approved April 1, 2016. Published April 2016. Originally approved in 1999. Last previous edition approved in 2012 as D6416/D6416M – 01(2012). DOI: 10.1520/D6416_D6416M-16E01.

² For referenced ASTM standards, visit the ASTM website, www.astm.org, or contact ASTM Customer Service at service@astm.org. For *Annual Book of ASTM Standards* volume information, refer to the standard's Document Summary page on the ASTM website.

³ Detailed drawings for the fabrication of the 500-mm test fixture and pressure bladder shown in Fig. 3 and Fig. 4 are available from ASTM Headquarters, www.astm.org. Order Adjunct No. ADJD6416-E-PDF.

between terms, Terminology **D3878** shall have precedence over the other terminology standards.

3.2 Definitions of Terms Specific to This Standard:

3.2.1 *bending stiffness, n*—the sandwich property which resists bending deflections.

3.2.2 *core, n*—a centrally located layer of a sandwich construction, usually low density, which separates and stabilizes the facings and transmits shear between the facings and provides most of the shear rigidity of the construction.

3.2.3 *face sheet, n*—the outermost layer or composite component of a sandwich construction, generally thin and of high density, which resists most of the edgewise loads and flatwise bending moments: synonymous with face, skin, and facing.

3.2.4 *footprint, n*—the enclosed area of the face sheet surface of a sandwich panel in contact with the pressure bladder during loading.

3.2.5 *hydromat, n*—a pressure bladder with a square perimeter fabricated from two square pieces of industrial belting which are superposed and clamped at the edges with through-bolted, mild steel bar stock.

3.2.6 *isotropic material, n*—a material having essentially the same properties in any direction.

3.2.7 *orthotropic material, n*—a material in which a property of interest, at a given point, possesses three mutually perpendicular planes of symmetry, which taken together define the principal material coordinate system.

3.2.8 *pressure bladder, n*—a durable, yet pliable closed container filled with water, or other incompressible fluid, capable of conforming to the contour of a normally loaded test panel when compressed against its face sheet surface by a test machine.

3.2.9 *shear stiffness, n*—the sandwich property which resists shear distortions: synonymous with shear rigidity.

3.2.10 *test panel, n*—a square coupon of sandwich construction fabricated for two-dimensional flexural testing: synonymous with sandwich panel, sandwich composite plate, sandwich composite panel, and panel test specimen.

3.3 Symbols:

3.3.1 a = support span of the test fixture or the length and width of the test panel structure between supports.

3.3.2 A_{eff} = effective contact area of the pressure bladder when compressed against the test panel.

3.3.3 B = test panel bending stiffness.

3.3.4 c = core thickness.

3.3.5 ϵ_x = normal face sheet strain, x component.

3.3.6 ϵ_y = normal face sheet strain, y component.

3.3.7 f = face sheet thickness.

3.3.8 F_m = total normal force applied to a test panel as measured by the test machine load cell.

3.3.9 h = average overall thickness of the test panel.

3.3.10 N = the number of included terms of the series.

3.3.11 P_m = experimentally measured bladder pressure.

3.3.12 ϕ = width of the unloaded border area of a test panel between the edge supports and the effective footprint boundary.

3.3.13 S = test panel shear stiffness.

3.3.14 ω_c = experimentally determined deflection at center of test panel.

4. Summary of Test Method

4.1 A square test panel is simply supported on all four edges and uniformly loaded over a portion of its surface by a water-filled bladder. Pressure on the panel is increased by moving the platens of the test frame. The test measures the two-dimensional flexural response of a sandwich composite plate in terms of deflections and strains when subjected to a well-defined distributed load.

4.2 Panel deflection at load is monitored by a centrally positioned LVDT which contacts the tension-side surface.

4.3 Load is monitored by both a crosshead-mounted load cell, in series with the test fixture, and a pressure transducer in the pressure bladder itself. Since the pressure bladder is also at all times in series with the load cell and test fixture, the effective contact area of the pressure field is continuously monitored as the load/pressure quotient.

4.4 Strain can be monitored with strategically placed strain gage rosettes bonded to the tension-side face-sheet surface. A typical arrangement has four rosettes equally spaced along one of the axes of symmetry of the plate.

5. Significance and Use

5.1 This test method simulates the hydrostatic loading conditions which are often present in actual sandwich structures, such as marine hulls. This test method can be used to compare the two-dimensional flexural stiffness of a sandwich composite made with different combinations of materials or with different fabrication processes. Since it is based on distributed loading rather than concentrated loading, it may also provide more realistic information on the failure mechanisms of sandwich structures loaded in a similar manner. Test data should be useful for design and engineering, material specification, quality assurance, and process development. In addition, data from this test method would be useful in refining predictive mathematical models or computer code for use as structural design tools. Properties that may be obtained from this test method include:

5.1.1 Panel surface deflection at load,

5.1.2 Panel face-sheet strain at load,

5.1.3 Panel bending stiffness,

5.1.4 Panel shear stiffness,

5.1.5 Panel strength, and

5.1.6 Panel failure modes.

6. Interferences

6.1 *Material and Specimen Preparation*—Poor material fabrication practices, lack of control of fiber alignment, and damage induced by improper coupon machining are known causes of high material data scatter in composites in general. Specific material factors that affect sandwich composites include variability in core density and degree of cure of resin in both face sheet matrix material and core bonding adhesive. Important aspects of sandwich panel specimen preparation that contribute to data scatter are incomplete wetout of face sheet

fabric, incomplete or nonuniform core bonding of face sheets, the non-squareness of adjacent panel edges, the misalignment of core and face sheet elements, the existence of joints or other core and face sheet discontinuities, out-of-plane curvature, and surface roughness.

6.2 Test Fixture Characteristics—Configuration of the panel edge-constraint structure can have a significant effect on test results. Correct interpretation of test data depends on the fixture supporting the test panel in such a manner that the boundary conditions consistent with simple support can be assumed to apply. Panel edge support journals must be coplanar and perpendicular to the loading axis. Given the fixture itself has sufficient rigidity, erroneous conclusions about panel strength and stiffness might be drawn if insufficient torque has been applied to the fasteners securing the lower panel edge support frame. In general, panels with more flexural rigidity and shear rigidity require more bolt torque to approach simple support.

6.3 Pressure Bladder Characteristics—When a pressure bladder is used to introduce normal load to a plate, the response of the plate is dependent on the resulting pressure distribution. The true function of the pressure bladder is to convert the absolute load applied by the test machine into a pressure field that can be specified by a relatively simple mathematical model. With the hydromat-style bladder, two simplifying assumptions are permitted: (1) the shape of the contact area is a readily definable geometric shape (or combination of shapes) and (2) the pressure is constant within the boundaries of the contact area. The pressure distribution is then characterized merely by the magnitude of the pressure and the size of the footprint. Obviously, the size and shape of the pressure bladder have a significant effect on test results in terms of the observed strains and deflections. Some errors in data interpretation are possible insofar as the actual pressure distribution differs from the simple mathematical model used in calculations.

NOTE 1—The error in the hydromat model has mainly to do with details of the footprint shape, since the effective contact area can be calculated at any time by dividing the absolute applied load by the bladder pressure. A secondary error arises from the non-zero bending stiffness of the fiber-reinforced industrial belting fabric that results in a narrow band of varying pressure at the very edge of the footprint. Calibration tests using a steel plate equipped with strain gages are recommended for each bladder unit to verify that the errors in the pressure distribution model are negligible (see Section 9).

6.4 Tolerances—Test panels need to meet the dimensional and squareness tolerances specified in 8.2 to ensure proper edge support and constraint.

6.5 System Alignment—Errors can result if the panel support structure is not centered with respect to the actuator of the test machine, or if the plane defined by the panel edge-bearing surfaces is not perpendicular to the loading axis of the test machine. Errors can also result if the pressure bladder is not centered properly with respect to fixture and actuator or if the edges of the bladder clamping bars are not parallel to the panel edge-support journals.

6.6 Other System Characteristics—When attempting to measure panel surface deflection, an error results which is an artifact of the test. It arises as normal load is applied, to the

extent that the edges of the sandwich specimen are compressed from the reactive line loads generated by the upper and lower panel support structure. This direct rigid-body addition affects any LVDT positioned to contact the tension-side panel surface. To minimize the error, the edges of soft-core panels should be reinforced in accordance with 8.3.2.

7. Apparatus

7.1 Procedures A, B, and C—A schematic diagram illustrating the key components of the test method apparatus appears in Fig. 1.

7.1.1 Testing Machine—The testing machine shall be in conformance with Practices E4 and shall satisfy the following requirements:

7.1.1.1 Testing Machine Heads—The testing machine shall have both an essentially stationary head and a movable head.

7.1.1.2 Drive Mechanism—The testing machine drive mechanism shall be capable of imparting to the movable head a controlled velocity with respect to the stationary head. The velocity of the movable head shall be capable of being regulated in accordance with 11.3.

7.1.1.3 Load Indicator—The testing machine load-sensing device shall be capable of indicating the total load being carried by the test specimen. This device shall be essentially free from inertia-lag at the specified rate of testing and shall indicate the load with an accuracy over the load range(s) of interest of within $\pm 1\%$ of the indicated value. The load range(s) of interest may be fairly low for bending and shear modulus evaluation or much higher for strength evaluation, or both, as required.

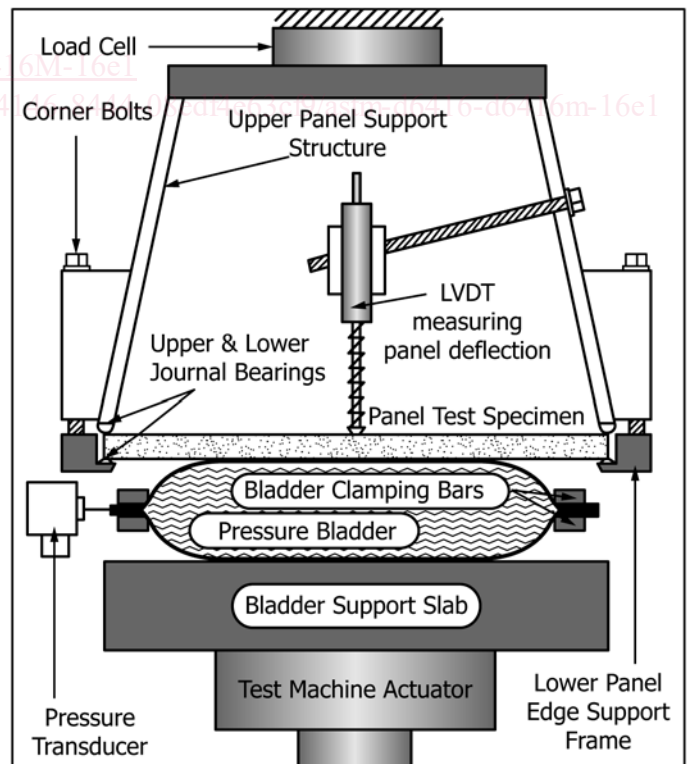

FIG. 1 Elements of the Two-Dimensional Sandwich Plate Flexural Test

7.1.2 *Loading Fixture*—As illustrated in the schematic diagram of Fig. 1, the loading fixture has two parts, a rigid, overhead upper panel support structure, which is attached to the load cell on the load frame crosshead, and a rigid lower panel edge support frame which bolts to the upper panel support structure at the corners. A square sandwich composite panel specimen is constrained at the edges when captured from above and below by these two fixture elements. All bearing surfaces are hardened steel rods with a circular cross-section, 12.7 mm [0.5 in.] in diameter. The support span for each dimension of the fixture is defined in Fig. 2. That the loading fixture constrains the test panel at all four edges is shown in the photographs of Figs. 3 and 4. Panel flexural response is thus two-dimensional under normal loading. The length of the support spans should be equal in both dimensions. Simply supported boundary conditions are approached as the lower panel edge support frame is drawn towards the upper panel support structure by tightening the four corner connecting bolts.

7.1.3 *Pressure Bladder*—Normal load is introduced to the test panel by means of a sealed water bladder which is compressed against the lower panel face by the bladder support slab that rests on the upward-moving lower platen. The bladder should be made of industrial belting, or other tough, flexible, waterproof fabric, and be capable of withstanding pressures of the order required to initiate failure in the test panel. Bladder skin should be of sufficient pliability to follow the contour of a test panel under a steadily increasing load, thus ensuring a uniform load distribution for the footprint. In Fig. 1, Fig. 3, and



FIG. 3 Two-Dimensional Plate Flexural Test Apparatus

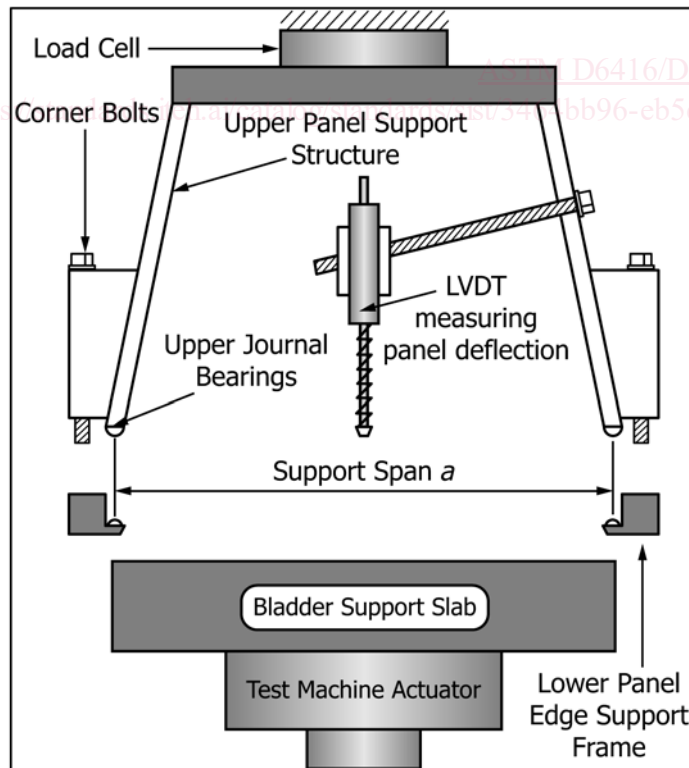

FIG. 2 Definition of Support Span for Specification of Panel Specimen Dimensional Tolerances

Fig. 4, through-bolted steel flatstock is used to clamp belting edges together to form the seal.

NOTE 2—The bladder size should be based on the inside dimensions of the test fixture rather than the outer dimensions of the test panel. It is important that during test loading the bladder contacts only the surface of the test panel. There must be no impingement of any part of the bladder on the lower panel edge support frame. It is recommended that the outer dimensions of any bladder clamping bar framework be less than the inside dimensions of the lower panel edge support frame so that clearance between the two will be maintained, even at significant panel deflections.

7.1.4 *Additional Instrumentation*—This test method requires bladder pressure and panel deflection sensors that shall meet the following requirements:

7.1.4.1 *Pressure Indicator*—The bladder pressure transducer must be in direct contact with the water by means of a tube that penetrates to the bladder interior. The connecting tube must be of sufficient diameter to permit pressure equilibrium with the interior without excessive lag time. The pressure transducer must be rated for the range of pressure magnitudes applied during the test and must respond with a precision of at least $\pm 1\%$ of the full-scale value over the pressure range explored.

7.1.4.2 *LVDT*—The device for measuring the deflection of the test panel must be capable of measuring the displacement with a precision of at least $\pm 1\%$. The plunger that connects the panel surface with the LVDT core should be equipped with a spring return to ensure continued monitoring of the panel displacement even during an unloading cycle.

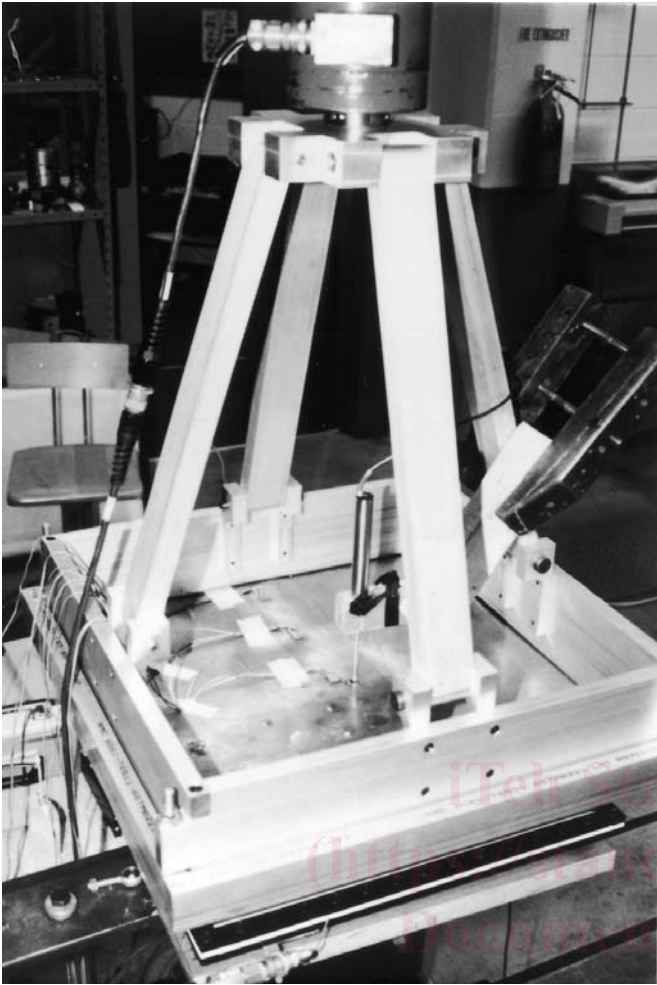

FIG. 4 Load Cell and Panel-Loading Fixture with Steel Calibration Plate

V is recommended) to reduce further the power consumed by the gage. Heating of the substrate by the gage may affect the performance of the material directly, or it may affect the indicated strain as a result of a difference between the gage temperature compensation factor and the coefficient of thermal expansion of the coupon material.

7.1.5.3 Temperature compensation is recommended when testing at standard laboratory atmosphere. Temperature compensation is required when testing in nonambient temperature environments. When appropriate, use a traveler coupon (dummy calibration coupon) with identical lay-up and strain gage orientations for thermal strain compensation.

7.1.5.4 Consider the transverse sensitivity of the selected strain gage. Consult the strain gage manufacturer for recommendations on transverse sensitivity corrections. This is particularly important for a transversely mounted gage.

7.1.6 *Torque Wrench*—To effect simple support for test panels of varying shear and bending stiffness, tension in the four corner bolts that connect the lower panel edge support frame to the upper panel support structure needs to be controlled. Since bolt-tension requirements are typically fairly low, with correspondingly low torque requirements, a reliable microtorque wrench is recommended for adjusting the fixture.

7.1.7 *Line-Load Diffuser Strips*—It is recommended that test panels with wood face sheets, or face sheets of any easily indentable material, be protected on the upper edges, where they contact the hard-surface upper panel journal bearings. Narrow strips of thin spring steel should be placed around the edges of the upper surface of the panel before securing it in the loading fixture. Fig. 5 is a diagram that illustrates the proper placement of such strips, flush with the panel outer edges. The thickness of the strips should be on the order of 1.6 mm [0.063 in.], while width should be based on the fixture support span. (See Fig. 2.) Length of the strips should be on the order of one third the panel length or width, so that they do not inhibit the free rotation of the panel edges.

7.1.5 *Bonded Face-Sheet Resistance Strain Gages*—Strain gage selection is a compromise based on the procedure and the type of material to be tested. Strain gages should have an active grid length of 3 mm [0.125 in.] or less (1.5 mm [0.06 in.] is preferable). Gage calibration certification shall comply with Test Methods E251. When testing woven fabric face sheet laminates, gage selection should consider the use of an active gage length which is at least as great as the characteristic repeating unit of the weave. Some guidelines on the use of strain gages on composites are presented as follows, with a general discussion on the subject in reference.

7.1.5.1 Surface preparation of fiber-reinforced composites in accordance with Guide E1237 can penetrate the matrix material and cause damage to the reinforcing fibers resulting in uncharacteristic local behavior. Reinforcing fibers shall not be exposed or damaged during the surface preparation process. Consult the strain gage manufacturer regarding surface preparation guidelines and recommended bonding agents for composites.

7.1.5.2 Select gages having larger resistances to reduce heating effects on low-conductivity materials. Resistances of 350 Ω or higher are preferred. Use the minimum possible gage excitation voltage consistent with the desired accuracy (1 to 2

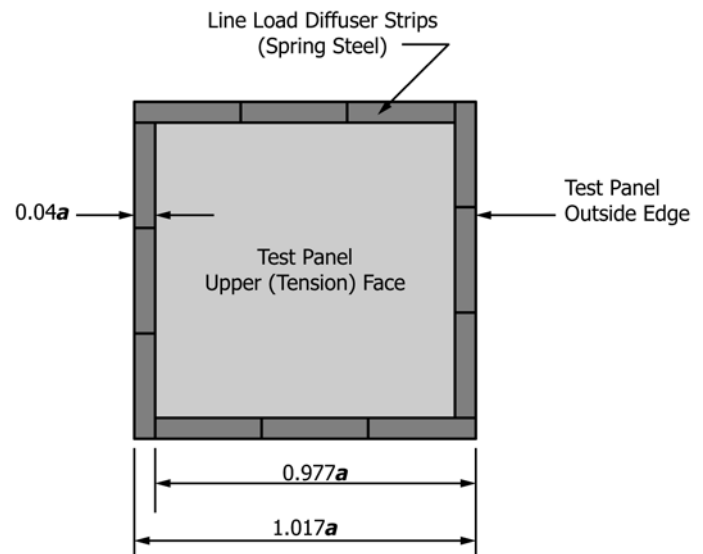

FIG. 5 Placement of Line Load Diffuser Strips

7.1.8 *Dial Calipers*—Dial calipers or conventional micrometers shall be sufficient for measuring panel thickness, provided they are accurate within ± 0.025 mm [± 0.001 in.].

8. Sampling and Test Specimens

8.1 *Sampling*—Because of the relatively large coupon size, one specimen per condition shall be considered sufficient.

NOTE 3—If specimens are to undergo environmental conditioning to equilibrium, and are of such type or geometry that the weight change of the material cannot be properly measured by weighing the specimen itself (such as when face sheets are bonded to a core), then a traveler coupon of the same nominal face sheet thickness and appropriate size but masked on one side (to simulate the protective effect of the core) shall be used to determine when equilibrium has been reached for the specimens being conditioned.

8.2 *Geometry*—The test specimen shall be a uniform sandwich composite plate structure with a square perimeter and constant thickness. Dimensional tolerances must be based on the support span of the available test fixture. (See Fig. 2.)

8.2.1 *Specimen Thickness*—Specimen thickness h is the average thickness as measured to the nearest 0.025 mm [0.001 in.] at the center of each edge, h_1 , h_2 , h_3 , and h_4 . There should be no more than a ± 2 % variation in the thickness of each edge with respect to the average thickness.

NOTE 4—There are no theoretical restrictions on the acceptable range of plate specimen thicknesses. However, to be an efficient load-bearing structure, the proportions of a simply supported sandwich plate should be such that the core material mainly carries shear load while the two face sheets mainly carry tension and compression loads, respectively. Therefore, for this test method to be the most helpful in optimizing sandwich structure, a thickness specification should be instituted which will enable a meaningful challenge to the constituent materials, in those terms, at small deflections. For example, if a panel specimen is too thin, small loads may induce large deflections where membrane effects become dominant. On the other hand, if a panel specimen is too thick, flexural response may be dominated by core shear properties. Since test machine capacities vary, it is advisable to recommend a range for specimen thickness based on the support span of the available test fixture. Therefore, for the testing of sandwich panels with the goal of learning how to optimize structural efficiency, the ratio of the support span to the average specimen thickness (a/h) should be between 10.0 and 30.0.

8.2.2 *Specimen Length and Width*—Specimen length and width should be 1.017 times the support span ($1.017a$) with a tolerance of $\pm 0.0025a$. See Fig. 6.

NOTE 5—From a practical standpoint, a panel test specimen needs to be slightly longer and wider than its edge supports. But the amount of panel structure which extends beyond or “overhangs” the edge supports needs to be restricted, insofar as it constitutes a violation of simply supported boundary conditions. In effect, a specimen with a greater overhang will appear to be stiffer than an otherwise identical specimen with a lesser overhang.

8.2.3 *Specimen Squareness*—The difference between the length of the two opposite diagonals (measured from corner to corner) should be less than or equal to $0.005a$. (See Fig. 6.)

8.3 Test Specimen Fabrication:

8.3.1 *Material and Process Documentation*—Although the need for complete and accurate documentation of test specimen composition and fabrication techniques is mentioned in Section 14, it is important to stress that construction details should be immediately recorded in a log after each step of the fabrication process. Composite construction is necessarily a complex

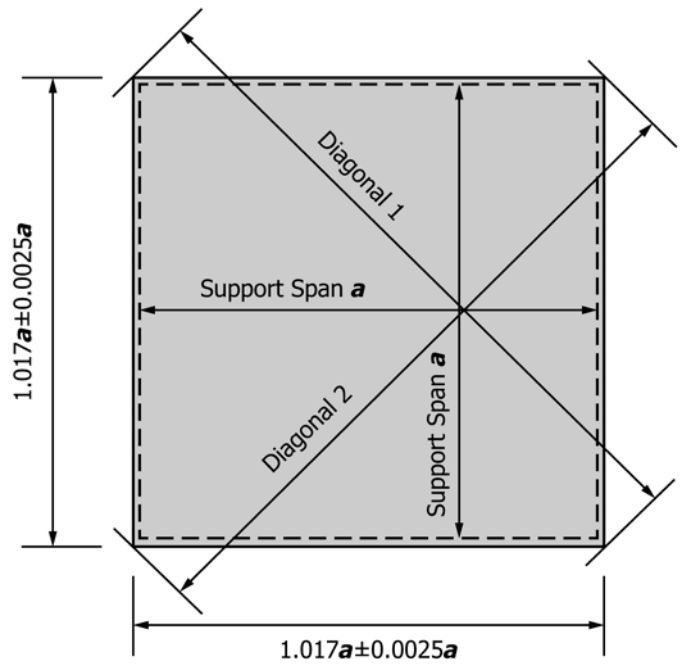

Squareness Tolerance:

$$\text{Absolute Value (Diagonal 1 - Diagonal 2)} \leq 0.005a$$

FIG. 6 Test Panel Length, Width, and Squareness Tolerances

process, and this test method can be effective in validating a particular fabrication method as well as the selection of constituent materials, if a detailed record exists. Enough information needs to be recorded and reported so that the experiment could be duplicated by any composites research facility. If possible, manufacturers' product numbers with actual lot numbers should be recorded. It is recommended that the core material piece which has been cut for specimen construction be carefully weighed and measured for density calculation before face sheet bonding in accordance with 11.2.2.

8.3.2 *Edge Reinforcement*—If the core material in the specimen has a compression modulus less than 300 MPa [43 512 psi] as determined in Test Method C365/C365M, the edges should be reinforced by installing between the face sheets a border of higher-modulus material such as end-grain wood, having a compression modulus of at least 2240 MPa [325 000 psi]. The border should be of a width on the order of $0.016a$, where a is the length of the support span. The overall length and width of the specimen is to remain as specified in 8.2.2. Preferably, this modification is to be included in the panel fabrication process and carried out before face sheet bonding, rather than done as a retrofit procedure.

9. Calibration

9.1 The accuracy of all measuring equipment shall have certified calibrations that are current at the time of use of the equipment.

9.2 The bladder loading and panel edge support are critical components of the two-dimensional test fixture which is sometimes referred to as the hydromat test system. To ensure