



Designation: F2665 – 21

Standard Specification for Total Ankle Replacement Prosthesis¹

This standard is issued under the fixed designation F2665; the number immediately following the designation indicates the year of original adoption or, in the case of revision, the year of last revision. A number in parentheses indicates the year of last reappraisal. A superscript epsilon (ϵ) indicates an editorial change since the last revision or reappraisal.

1. Scope

1.1 This specification covers total ankle replacement (TAR) prostheses used to provide functioning articulation by employing talar and tibial components that allow for a minimum of 15° of dorsiflexion and 15 to 25° (**1**)² of plantar flexion, as determined by non-clinical testing.

1.2 Included within the scope of this specification are ankle components for primary and revision surgery with modular and non-modular designs, bearing components with fixed or mobile bearing designs, and components for cemented and/or cementless use.

1.3 This specification is intended to provide basic descriptions of material and prosthesis geometry. In addition, those characteristics determined to be important to the *in-vivo* performance of the prosthesis are defined.

1.4 The values stated in SI units are to be regarded as standard. No other units of measurement are included in this standard.

1.5 *This standard does not purport to address all of the safety concerns, if any, associated with its use. It is the responsibility of the user of this standard to establish appropriate safety, health, and environmental practices and determine the applicability of regulatory limitations prior to use.*

1.6 *This international standard was developed in accordance with internationally recognized principles on standardization established in the Decision on Principles for the Development of International Standards, Guides and Recommendations issued by the World Trade Organization Technical Barriers to Trade (TBT) Committee.*

¹ This specification is under the jurisdiction of ASTM Committee F04 on Medical and Surgical Materials and Devices and is the direct responsibility of Subcommittee F04.22 on Arthroplasty.

Current edition approved April 1, 2021. Published April 2021. Originally approved in 2009. Last previous edition approved in 2014 as F2665 – 09 (2014). DOI: 10.1520/F2665-21.

² The boldface numbers in parentheses refer to a list of references at the end of this standard.

2. Referenced Documents

2.1 ASTM Standards:³

- F67 Specification for Unalloyed Titanium, for Surgical Implant Applications (UNS R50250, UNS R50400, UNS R50550, UNS R50700)
- F75 Specification for Cobalt-28 Chromium-6 Molybdenum Alloy Castings and Casting Alloy for Surgical Implants (UNS R30075)
- F86 Practice for Surface Preparation and Marking of Metallic Surgical Implants
- F90 Specification for Wrought Cobalt-20Chromium-15Tungsten-10Nickel Alloy for Surgical Implant Applications (UNS R30605)
- F136 Specification for Wrought Titanium-6Aluminum-4Vanadium ELI (Extra Low Interstitial) Alloy for Surgical Implant Applications (UNS R56401)
- F138 Specification for Wrought 18Chromium-14Nickel-2.5Molybdenum Stainless Steel Bar and Wire for Surgical Implants (UNS S31673)
- F451 Specification for Acrylic Bone Cement
- F561 Practice for Retrieval and Analysis of Medical Devices, and Associated Tissues and Fluids
- F562 Specification for Wrought 35Cobalt-35Nickel-20Chromium-10Molybdenum Alloy for Surgical Implant Applications (UNS R30035)
- F648 Specification for Ultra-High-Molecular-Weight Polyethylene Powder and Fabricated Form for Surgical Implants
- F732 Test Method for Wear Testing of Polymeric Materials Used in Total Joint Prostheses
- F746 Test Method for Pitting or Crevice Corrosion of Metallic Surgical Implant Materials
- F748 Practice for Selecting Generic Biological Test Methods for Materials and Devices

³ For referenced ASTM standards, visit the ASTM website, www.astm.org, or contact ASTM Customer Service at service@astm.org. For *Annual Book of ASTM Standards* volume information, refer to the standard's Document Summary page on the ASTM website.

- F799** Specification for Cobalt-28 Chromium-6 Molybdenum Alloy Forgings for Surgical Implants (UNS R31537, R31538, R31539)
- F981** Practice for Assessment of Compatibility of Biomaterials for Surgical Implants with Respect to Effect of Materials on Muscle and Insertion into Bone
- F983** Practice for Permanent Marking of Orthopaedic Implant Components
- F1108** Specification for Titanium-6Aluminum-4Vanadium Alloy Castings for Surgical Implants (UNS R56406)
- F1223** Test Method for Determination of Total Knee Replacement Constraint
- F1377** Specification for Cobalt-28Chromium-6Molybdenum Powder for Coating of Orthopedic Implants (UNS R30075)
- F1472** Specification for Wrought Titanium-6Aluminum-4Vanadium Alloy for Surgical Implant Applications (UNS R56400)
- F1537** Specification for Wrought Cobalt-28Chromium-6Molybdenum Alloys for Surgical Implants (UNS R31537, UNS R31538, and UNS R31539)
- F1580** Specification for Titanium and Titanium-6 Aluminum-4 Vanadium Alloy Powders for Coatings of Surgical Implants
- F1609** Specification for Calcium Phosphate Coatings for Implantable Materials
- F1800** Practice for Cyclic Fatigue Testing of Metal Tibial Tray Components of Total Knee Joint Replacements
- F1814** Guide for Evaluating Modular Hip and Knee Joint Components
- F1877** Practice for Characterization of Particles
- F2003** Practice for Accelerated Aging of Ultra-High Molecular Weight Polyethylene after Gamma Irradiation in Air
- F2083** Specification for Knee Replacement Prosthesis
- F2503** Practice for Marking Medical Devices and Other Items for Safety in the Magnetic Resonance Environment
- F2565** Guide for Extensively Irradiation-Crosslinked Ultra-High Molecular Weight Polyethylene Fabricated Forms for Surgical Implant Applications
- F2695** Specification for Ultra-High Molecular Weight Polyethylene Powder Blended With Alpha-Tocopherol (Vitamin E) and Fabricated Forms for Surgical Implant Applications
- F2943** Guide for Presentation of End User Labeling Information for Musculoskeletal Implants

2.2 ISO Standards:⁴

- ISO 6474-1** Implants for Surgery—Ceramic Materials—Part 1: Ceramic Materials Based on High-Purity Alumina
- ISO 10993-1** Biological Evaluation of Medical Devices—Part 1: Evaluation and testing within a risk management process
- ISO 13179-1** Implants for surgery—Plasma-sprayed unalloyed titanium coatings on metallic surgical implants—Part 1: General requirements

- ISO 13779-2** Implants for surgery—Hydroxyapatite—Part 2: Thermally sprayed coatings of hydroxyapatite
- ISO 14243-2** Implants for Surgery—Wear of Total Knee-Joint Prostheses—Part 2: Methods of Measurement
- ISO 22622** Implants for surgery—Wear of total ankle-joint prostheses—Loading and displacement parameters for wear-testing machines with load or displacement control and corresponding environmental conditions for test
- 2.3 *FDA Documents:*⁵
- 21 CFR 888.6** Degree of Constraint
- 21 CFR 888.3110** Ankle Joint Metal/Polymer Semi-Constrained Cemented Prostheses
- 21 CFR 888.3120** Ankle Joint Metal/Polymer Non-Constrained Cemented Prostheses
- 2.4 *ANSI/ASME Standard:*⁴
- ANSI/ASME B46.1–1995** Surface Texture (Surface Roughness, Waviness, and Lay)

3. Terminology

3.1 Definitions of Terms Specific to This Standard:

- 3.1.1 *constraint, n*—the relative inability of a TAR, inherent to its geometrical and material design, to be further displaced in a specific direction under a given set of loading conditions.
- 3.1.2 *dorsiflexion, n*—rotation of the tibial component towards the anterior talar surface.
- 3.1.3 *flexion, n*—rotation of the talar component relative to the tibial component around the medial-lateral axis. Flexion is considered positive when it is dorsiflexion, and negative when it is plantar flexion.
- 3.1.4 *IE rotation, n*—rotation of the tibial component relative to the talar component around the tibial axis. IE rotation is considered positive when the tibial component rotates internally (clockwise when viewed proximally on the left ankle). IE rotation is considered negative when the tibial component rotates externally.
- 3.1.5 *interlock, n*—mechanical design feature used to increase capture of one component within another and to restrict unwanted displacement between components (that is, component locking mechanism for modular components).
- 3.1.6 *plantar flexion, n*—rotation of the tibial component toward the posterior talar surface.
- 3.1.7 *radiographic marker, n*—a nonstructural wire or bead designed to be apparent on X-rays taken after implantation for those components that would otherwise not be apparent on such X-rays.
- 3.1.8 *subluxation, n*—instability or partial dislocation which occurs when the relative translational or rotational motion between the talar and tibial components reaches an extreme where the two components would cease to articulate over the designated low friction-bearing surfaces.
- 3.1.9 *talar component, n*—bearing member fixed to the talus for articulation with the tibial component. This could be metallic or from some other suitably hard surface material.

⁴ Available from American National Standards Institute (ANSI), 25 W. 43rd St., 4th Floor, New York, NY 10036, <http://www.ansi.org>.

⁵ Available from Food and Drug Administration (FDA), 5600 Fishers Ln., Rockville, MD 20857, <http://www.fda.gov>.

3.1.10 *tibial component, n*—fixed or mobile bearing member attached to the tibia for articulation with the talar component, typically consisting of two major components: a metallic tibial tray and an ultra-high-molecular-weight polyethylene (UHMWPE) (see Specification **F648**) bearing surface.

3.1.11 *total ankle replacement (TAR), n*—prosthetic parts that substitute for the natural opposing tibial and talar articulating surfaces.

4. Classification

4.1 The following classification by degree of constraint is suggested for all total joint prostheses, including total ankle replacement systems, based on the concepts adopted by the U.S. Food and Drug Administration (see 21 CFR 888.6).

4.1.1 *Constrained*—A constrained joint prosthesis prevents dislocation of the prosthesis in more than one anatomic plane and consists of either a single, flexible, across-the-joint component or more than one component linked together or affixed.

4.1.2 *Semi-Constrained*—A semi-constrained joint prosthesis limits translation or rotation, or both translation and rotation of the prosthesis in one or more planes via the geometry of its articulating surfaces. Its components have no across-the-joint linkages.

4.1.3 *Non-Constrained*—A non-constrained joint prosthesis minimally restricts prosthesis movement in one or more planes. Its components have no across-the-joint linkages.

4.2 Currently, most ankle designs are considered either semi-constrained or non-constrained. Most mobile bearing ankle components are considered non-constrained. The U.S. government, in 21 CFR 888.3110, identifies “ankle joint metal/polymer semi-constrained cemented prosthesis” and, in 21 CFR 888.3120, identifies “ankle joint metal/polymer non-constrained cemented prosthesis.”

5. Material

5.1 All devices conforming to this specification shall be fabricated from materials with adequate mechanical strength, durability, corrosion resistance, and biocompatibility.

NOTE 1—The choice of materials is understood to be a necessary but not totally sufficient assurance of proper function of the device made from them.

5.1.1 *Mechanical Strength*—Various metallic components of total ankle replacement devices have been successfully fabricated from materials, as examples, found in Specifications **F75**, **F90**, **F136**, **F138**, **F562**, **F799**, **F1108**, **F1377**, **F1472**, **F1537**, and **F1580**. Polymeric bearing components have been fabricated from UHMWPE, for example, as specified in Specifications **F648** and **F2695** and Guide **F2565**. Porous coatings have been fabricated from example materials specified in Specifications **F67**, **F75**, and **F1609**; ISO 13779-2, and ISO 13179-1. Not all of these materials may possess sufficient mechanical strength for critical, highly stressed components or for articulating surfaces. Conformance of a selected material to its standard and successful clinical usage of the material in a previous implant design are not sufficient to ensure the strength of an implant. Manufacturing processes and implant design can strongly influence the device’s performance characteristics.

Therefore, regardless of the material selected, the ankle implant must meet the performance requirements of Section 6.

5.1.2 *Corrosion Resistance*—Materials with limited or no history of successful use for orthopaedic implant application shall exhibit corrosion resistance equal to or better than one of the materials listed in 5.1.1 when tested in accordance with Test Method **F746**.

5.1.3 *Biocompatibility*—Devices made from materials with limited or no history of successful use for orthopaedic implant application shall be determined to exhibit acceptable biological response when tested in accordance with Practices **F748**, **F981**, or ISO 10993-1. While no known surgical implant material has ever been shown to be completely free of adverse reactions in the human body, long-term clinical experience has shown an acceptable level of biological response can be expected if materials listed in 5.1.1 are used. However, the specifications listed in 5.1.1 cover raw materials and not finished medical devices, where the design and fabrication process of the device can impact biological response. Hence, for a device made from material listed in 5.1.1, its biocompatibility shall be verified in accordance with Practices **F748**, **F981**, or ISO 10993-1, unless justification can be provided for why design and processing will not impact the biocompatibility of the final, sterilized device.

5.1.4 *Polymeric Component Oxidation Resistance*—Polymeric components may be subject to degradation of mechanical or wear performance due to oxidation and may need to be aged prior to subsequent mechanical testing following Practice **F2003**.

6. Performance Requirements

6.1 *Component Function*—Each component for total ankle arthroplasty is expected to function as intended when manufactured in accordance with good manufacturing practices and to the requirements of this specification. The components shall be capable of withstanding static and dynamic physiologic loads (1) without compromising their function for the intended use and environment. All components used for experimental measures of performance shall be equivalent to the finished product in form and material. Components shall be sterilized if the sterilization process will affect their performance.

NOTE 2—Computer models may be used to evaluate many of the functional characteristics if appropriate material properties and functional constraints are included and the computer models have been validated with experimental tests.

6.1.1 Individual tibial (that is, tibial tray and bearing surface components) and talar components should be fatigue tested using relevant or analogous test methods under appropriate loading conditions (including worst-case scenarios) to address loss of supporting foundation leading to potential deformation and/or component fracture.

6.1.1.1 Tibial tray components may be evaluated in a manner similar to Practice **F1800**, with a loading moment value chosen to compare with a clinically successful implant, or justified in other suitable ways for the design being tested) (2). In choosing the loading moment, both the moment arm and the load used shall be specified with explanation as to how and why they were chosen. Each of five specimens shall be tested

for 10 million cycles with no failure. All tibial components designated by this specification shall pass this minimum requirement.

6.1.1.2 Tibial bearing surface components shall be fatigue tested considering worst-case scenarios to demonstrate that the component is able to withstand anticipated physiological loading conditions and is not susceptible to the failure modes that have been reported in the literature (3-5). The worst-case scenarios should take into consideration loads, component sizes, thickness of the plastic bearing insert, bony support, locking mechanism, edge loading, misalignments, and how these can affect the individual design.

6.1.2 Contact area and contact pressure distributions may be determined at various flexion angles using one of several published methods (6-11) to provide a representation of stresses applied to the bearing surfaces and to the components. Flexion angles of 0°, ±10°, and ±15° are recommended. If the prosthesis is designed to function at higher angles of dorsiflexion or plantar flexion, then it is recommended that these measurements be continued at 5° increments to the full range of motion. If these tests are performed, it is important to maintain consistent test parameters and to evaluate other TAR prostheses under the same conditions.

6.1.3 Range of motion in dorsiflexion and plantar flexion shall be greater than or equal to 15° (each) which is required for walking (12-14). These measurements apply to components mounted in neutral alignment in bone or in an anatomically representative substitute. It is critical to define the location of the neutral alignment position, for example, center of contact areas or patches, in terms of dimensions from outside edges of the components. The initial positioning or location of the neutral alignment point will affect the range of motion values for certain TAR prostheses. The range of flexion determined from non-clinical testing, therefore, can be compromised by misalignments in various degrees of freedom. Worst-case scenario misalignments as well as neutral alignment should be evaluated for dorsiflexion and plantar flexion range of motion testing.

NOTE 3—The nominal range of motion of a total ankle replacement can be estimated using the computer-aided design (CAD) of an implant. The definition of zero degrees of ankle flexion for the implant should be reported. The actual maximum dorsiflexion and maximum plantar flexion should be defined as the maximum angle at which the following conditions are met: (1) bony impingement is not expected, (2) the edges of the talar component or tibial component do not dig into the UHMWPE bearing (if any), and (3) the implant system can sustain a compressive load of 3600 N (approximately five average body weights) (13, 15) and a combination of the translational and rotational extreme laxity motions claimed in the design without subluxation.

6.1.4 Total ankle replacement constraint data for internal-external rotation, anterior-posterior displacement, and medial-lateral displacement should be determined for all total ankle joints in a manner similar to Test Method F1223 for total knees. Implants should be tested at 0°, ±10° and maximum flexion at a minimum.

6.2 All modular components shall be evaluated for the integrity of their connecting mechanisms. As suggested in Guide F1814, static and dynamic shear tests, bending tests, and tensile tests or any combination may be necessary to determine

the performance characteristics. The connecting mechanisms shall show sufficient integrity for the range of loads anticipated for the application.

6.3 It is important to understand the wear performance for articulating surfaces. Any new or different material couple shall not exceed the wear rates of the following material couple when tested under simulated physiological conditions, or if it does exceed these rates its use shall be further justified. The current standard wear couple is CoCrMo alloy (see Specification F75) against a fixed bearing UHMWPE (see Specification F648), both having prosthetic-quality surface finishes as described in 8.2 and 8.3.

6.3.1 Materials may be preliminarily tested in a pin-on-flat or pin-on-disk test apparatus such as described in Test Method F732 with adequate controls for comparison. A number of different load levels may be used to cover the range of anticipated stresses between articulating components.

NOTE 4—In situations in which the pin-on-flat test may not be considered appropriate, other tests may be considered, for example, ankle simulation modes of prosthesis wear performance testing or those described in ISO 6474-1 or other published documents.

6.3.2 Functional (simulated) wear tests of the device shall be performed to evaluate the tibiotalar articulation during walking gait according to ISO 22622, unless a justification is provided for not conducting wear testing or using another method. Since it is unlikely that one set of test conditions can simulate all aspects of ankle function, it is recommended that various test conditions be considered. Among the simulated conditions, there should be consideration of the effect of third-body abrasive interaction.

6.3.3 Evaluation of wear shall be performed using gravimetric techniques in accordance with ISO 14243-2. Other methods can additionally be used for evaluation, such as semiquantitative measures of damage assessment.

6.3.4 It may be important to understand the characteristics of debris generated during the wear tests, especially when extra articulations and potential new wear mechanisms can occur depending on the materials and design of the ankle prosthesis (for example, mobile bearing ankles). Wear debris generated from specific wear tests of new materials or designs may be characterized for morphology and size distribution in accordance with Practice F1877 and compared to wear debris from standard controls, collected from *in-vivo* clinical service, animal studies, or from reference literature. The wear debris also may be characterized for biological response in accordance with Practice F748 or ISO 10993-1. Practice F561 provides techniques for retrieval and isolation of debris that may be applicable for wear test fluids.

6.4 Characterization of Coatings:

6.4.1 *Metallic Coatings*—Information and testing of metallic coatings shall include a description and chemistry of the materials used (for example, powders, beads, fiber metal); plus, coating chemical analysis, morphology, and mechanical properties (for example, static shear strength, static tensile strength, shear fatigue strength, and abrasion resistance). Information is included in ISO 13179-1 for plasma-sprayed titanium coatings, for reference.

6.4.2 *Hydroxyapatite and Other Calcium Phosphate Coatings*—Information and testing of hydroxyapatite and other calcium phosphate coatings shall include a description of the powders used; plus, coating Ca/P ratio, trace elements, foreign crystalline phases, crystallinity ratio, morphology, coating strength (including static shear strength, static tensile strength, and shear fatigue strength), dissolution, and infrared spectroscopy. These requirements are included in ISO 13779-2 for reference.

7. Dimensions

7.1 Dimensions of total ankle replacement components may be designated in accordance with Fig. 1 and the items specified in the glossary. The tolerance and methods of dimensional measurement shall conform to industry practice and be on an international basis, whenever possible.

8. Finishing and Marking

8.1 Metallic components conforming to this specification shall be finished and marked in accordance with Practice F86, where applicable.

8.2 *Metallic Bearing Surface*—The main bearing surfaces shall have a surface finish no rougher than 0.10 μm (4 μin.) roughness average, R_a , when measured in accordance with the principles given in ANSI/ASME B46.1–1995. The following details should be documented: stylus tip radius, cutoff length of measuring instrument (0.25 mm is recommended), and position

of measurement on the specimen. When inspected visually, the component shall be free from embedded particles, defects with raised edges, scratches, and score marks.

8.3 *Polymeric Bearing Surface*—The main bearing surface of a UHMWPE component shall have a surface roughness no greater than 2-μm (80-μin.) roughness average, R_a , when measured in accordance with the principles given in ANSI/ASME B46.1–1995. The following details should be documented: stylus tip radius, cutoff length of the measuring instrument (0.80 mm is recommended), and the position of measurement on the specimen. When inspected with normal or corrected vision, the bearing surface shall be free from scale, embedded particles, scratches, and score marks other than those arising from the finishing process.

NOTE 5—Measurements should be taken in at least two orthogonal directions.

8.4 In accordance with Practices F86 and F983, items conforming to this specification shall be marked as follows in order of priority where space permits: manufacturer, material, lot number, catalog number, and size. Additional markings may be included (for example, left, right, front, and so forth).

8.5 If one of the components is not radiographically opaque, it may be appropriately marked for radiographic evaluation. If a radiographic marker is used, it should be placed in a noncritical area to avoid degrading the structural and functional properties of the device.

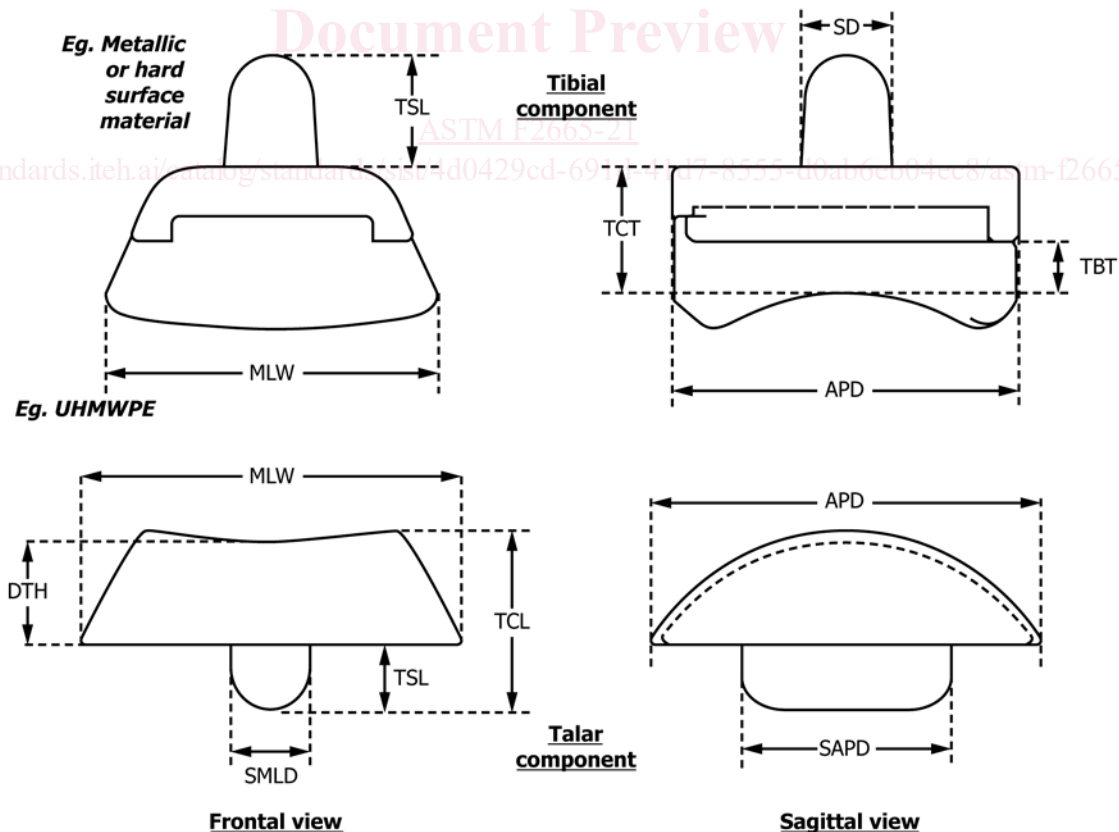

FIG. 1 General Depiction of Important Attributes of One Example Set of Semi-Constrained Fixed Bearing Total Ankle Arthroplasty Components (for terminology, see Appendix X1)