



Designation: D4338 – 97 (Reapproved 2021)

Standard Test Method for Flexibility Determination of Supported Adhesive Films by Mandrel Bend¹

This standard is issued under the fixed designation D4338; the number immediately following the designation indicates the year of original adoption or, in the case of revision, the year of last revision. A number in parentheses indicates the year of last reapproval. A superscript epsilon (ϵ) indicates an editorial change since the last revision or reapproval.

This standard has been approved for use by agencies of the U.S. Department of Defense.

1. Scope

1.1 This test method covers the determination of the flexibility of an adhesive film bonded to a flexible substrate. The results are useful for comparing flexibility of adhesives and not for absolute characterization of adhesives.

1.2 The values stated in SI units are to be regarded as the standard. The values given in parentheses are provided for information purposes only.

1.3 *This standard does not purport to address all of the safety concerns, if any, associated with its use. It is the responsibility of the user of this standard to establish appropriate safety, health, and environmental practices and determine the applicability of regulatory limitations prior to use.*

1.4 *This international standard was developed in accordance with internationally recognized principles on standardization established in the Decision on Principles for the Development of International Standards, Guides and Recommendations issued by the World Trade Organization Technical Barriers to Trade (TBT) Committee.*

2. Referenced Documents

2.1 *ASTM Standards:*²

D609 Practice for Preparation of Cold-Rolled Steel Panels for Testing Paint, Varnish, Conversion Coatings, and Related Coating Products

D907 Terminology of Adhesives

D3111 Practice for Flexibility Determination of Hot-Melt Adhesives by Mandrel Bend Test

¹ This test method is under the jurisdiction of ASTM Committee D14 on Adhesives and is the direct responsibility of Subcommittee D14.10 on Working Properties.

Current edition approved April 1, 2021. Published April 2021. Originally approved in 1984. Last previous edition approved in 2016 as D4338 – 97 (2016). DOI: 10.1520/D4338-97R21.

This test method is intended to replace Method 1081 of Federal Test Method 175A. Available from DLA Document Services, Building 4/D, 700 Robbins Ave., Philadelphia, PA 19111-5094, <http://quicksearch.dla.mil>.

² For referenced ASTM standards, visit the ASTM website, www.astm.org, or contact ASTM Customer Service at service@astm.org. For *Annual Book of ASTM Standards* volume information, refer to the standard's Document Summary page on the ASTM website.

[E171 Practice for Conditioning and Testing Flexible Barrier Packaging](#)

3. Terminology

3.1 *Definitions*—For terms used in this standard, refer to Terminology D907.

3.2 *Definitions of Terms Specific to This Standard:*

3.2.1 *mandrel, n*—cylindrical rod.

4. Summary of Test Method

4.1 A test substrate coated with a film of adhesive, properly sized and conditioned, is folded to form an inverted U-shaped angle over the mandrel maintaining intimate contact with the non-adhesive side. Using a fresh specimen for each test, the test is repeated with progressively smaller diameter mandrels until the adhesive fails (cracks) on bending. The flexibility value of the adhesive is the smallest diameter mandrel over which four out of five test specimens do not break.

5. Significance and Use

5.1 The mandrel bend test is simple and fast. It requires little investment in equipment and little operator training. The prime purpose is to determine whether a film of adhesive coated on a substrate meets flexibility requirements. The test is also useful for comparing flexibility of adhesives. It can be used to design adhesives by comparing the flexibility of various formulations to meet specific end-use parameters. The adhesive flexibility can be determined at temperatures other than ambient by conditioning the test apparatus and test specimen at the desired temperature and performing the test under those conditions.

6. Apparatus

6.1 The test apparatus consists of a series of different diameter cylindrical rods or mandrels supported at each end. These should be long enough to permit placement of the flat side of a test specimen tangentially at right angles to the longitudinal axis of the test mandrel. Individual requirements determine the diameter and lengths of the rods needed. For most tests, rods 3.2 mm (1/8 in.), 6.4 mm (1/4 in.), and 12.8 mm (1/2 in.) in diameter, by 75 to 150 mm (3 to 6 in.) in length, made of brass or stainless steel, are satisfactory. Two simple

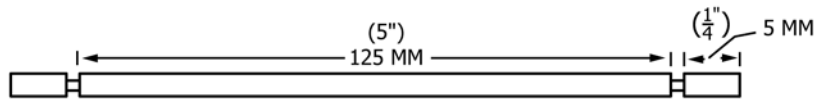
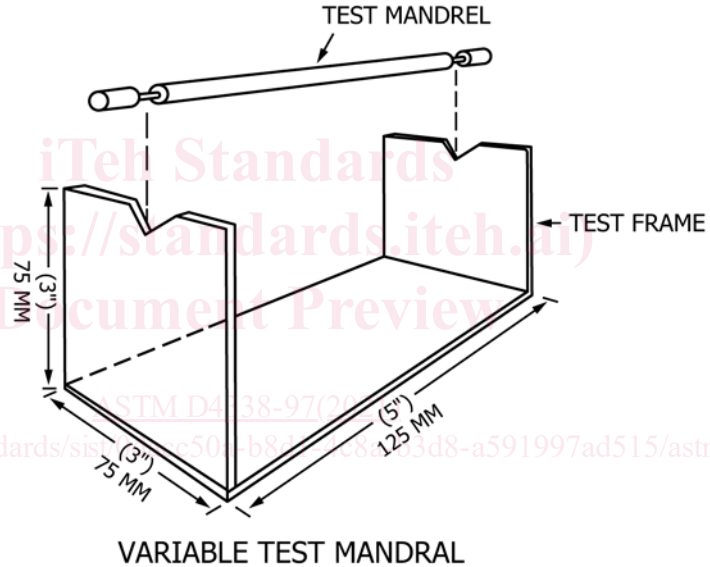
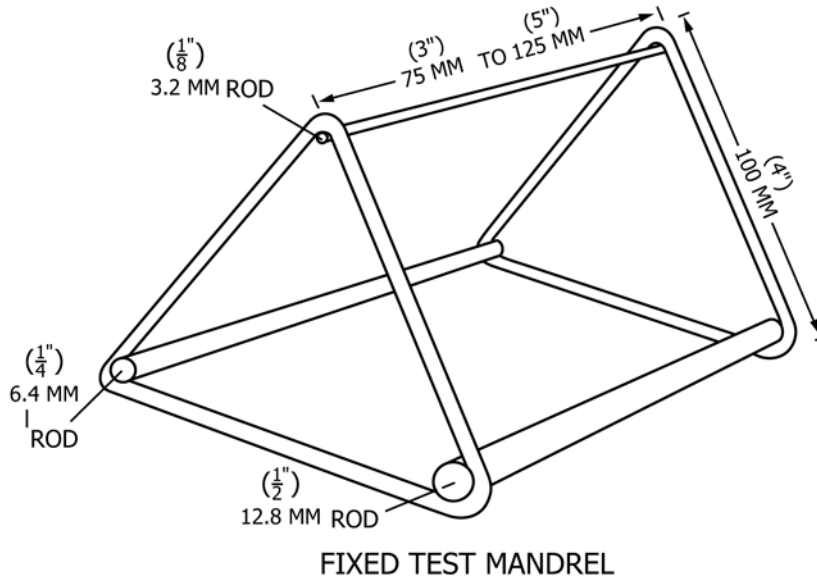

NOTE 1—Figures in parentheses are approximate.

FIG. 1 Test Mandrel (Various Diameters) for Test Frame

test frames are shown in Fig. 1, one with fixed mandrels, and the other designed to take any diameter mandrel.³

6.2 *Test Support Panels*, unless otherwise specified, are made of steel, not thinner than 0.25 mm (0.010 in.) nor thicker than 0.40 mm (0.016 in.).

6.2.1 The steel test panels are to be free of rust, corrosion, and contamination. Prepare one face of each panel to a clean surface according to Methods D609 to allow better adhesion of

the adhesive to be tested. An alternative to these steel test panels can be bonderized steel panels as available commercially.

6.2.2 Although steel is used in this test method, other flexible support substrates can be used, including other metals, plastics, and paper. Special surface preparation, for example, priming, corona discharge, and etching, can be defined for these substrates before coating the adhesive.

6.3 *Device*, capable of producing adhesive coatings of uniform thickness within (± 1 -mL) tolerances, such as a doctor blade.

³ Available from Paul N. Gardner Company, Inc., 313 NE 1st St. Pompano Beach, FL 33060.

7. Sampling, Test Specimens, and Test Units

7.1 The test sample will be representative of the adhesive tested.

7.2 Measure substrate.

7.3 Prepare test coating as follows:

7.3.1 A doctor blade is normally used to cast a uniform adhesive film at least 50 mm (2 in.) wide 100 mm (4 in.) long and of the thickness desired to the clean side of the steel test support panel or to any other designated test support substrate. If a suitable doctor blade is not used or available, other mutually acceptable coating procedures such as dip, flow, and spray can be used as long as a uniform coating results meeting the required thickness. Allow adhesive to set as described in the materials specifications or if not given, as recommended by the manufacturer of the adhesive. No flaws anywhere in the adhesive film visible to the naked eye are permitted. Measure the thickness dimension to within 0.01 mm (0.0004 in.).

8. Conditioning

8.1 Store the test specimens and test apparatus at the test conditions for 24 h. Perform the test under these same conditions. For rapid screening, particularly at low temperatures, a minimum of 4 h conditioning can be used. Note this change when recording data. If other conditions are not specified, the storage and test conditions are $23 \pm 2^\circ\text{C}$ and $50 \pm 5\%$ relative humidity. Specification E171 details these and other test conditions.

9. Procedure

9.1 Run the tests in the same environment used to condition the test specimens and test apparatus.

9.2 Put the largest diameter mandrel in the horizontal operating position in the test frame.

9.3 Grasp the test specimen between the thumb and forefinger of one hand, with the longest dimension between the fingers. For low-temperature testing, use cotton work gloves to insulate the test specimens from the warm fingers.

9.4 Lay the flat steel (or other support substrate) of the test specimen tangentially at right angles to the longitudinal axis of the test mandrel.

9.5 Within 1 s, fold the test specimen with the adhesive side opposite to the mandrel to form an inverted *U*-shaped angle over the mandrel maintaining intimate contact with the mandrel.

9.6 Failure is a fracture, crazing, or cracking of the adhesive film visible to the naked eye. This can occur at any time during the bending of the adhesive test specimen over the mandrel. Color changes or blushing, not affecting the tensile properties of the materials, are not considered as failure, but should be reported.

9.7 If no failure occurs, fold a fresh specimen over the next smaller diameter mandrel. Repeat the test using a fresh sample each time until failure occurs.

9.8 Repeat the test five times, using five fresh specimens, on the smallest-diameter mandrel at which failure had not occurred; at least four out of five test specimens must pass. Follow this procedure with smaller- or larger-diameter mandrels until four out of five test specimens pass.

9.9 Record the flexibility value of the adhesive as the smallest-diameter mandrel over which four out of five test specimens passed.

10. Report

10.1 The report should include the following:

10.1.1 Complete identification of the material tested, including types, source, manufacturer's code number, forms, etc.

10.1.2 Method of test specimen preparation, dipped, drawn down, flowed, sprayed, or other method.

10.1.3 Test specimen dimension, especially adhesive coating thickness to within 0.0025 mm (0.01 in.) substrate thickness.

10.1.4 Number of coats of adhesive applied.

10.1.5 Set time for each coat, temperature, and if important, relative humidity.

10.1.6 Conditioning and test conditions: temperature and relative humidity.

10.1.7 Smallest-diameter mandrel over which four out of five test specimens did not fail.

10.1.8 Observation for cracks, flakes, or chips in adhesive upon bending of test panel for each individual test.

10.1.9 Color change or blushing if visible of nonfailing test specimens after bending.

11. Precision and Bias

11.1 This is a comparative, working test. No precision or bias study is needed.

12. Keywords

12.1 flexibility; mandrel bend; supported adhesive