



Designation: F794 – 21

Standard Specification for Poly(Vinyl Chloride) (PVC) Profile Gravity Sewer Pipe and Fittings Based on Controlled Inside Diameter¹

This standard is issued under the fixed designation F794; the number immediately following the designation indicates the year of original adoption or, in the case of revision, the year of last revision. A number in parentheses indicates the year of last reapproval. A superscript epsilon (ϵ) indicates an editorial change since the last revision or reapproval.

This standard has been approved for use by agencies of the U.S. Department of Defense.

1. Scope*

1.1 This specification covers requirements for poly(vinyl chloride) (PVC) profile sewer pipe and fittings with integral bell and elastomeric seal joints or plain end pipe with couplings in sizes (4 to 48 in.) based on a controlled inside diameter.

1.2 The values stated in inch-pound units are to be regarded as standard. The values given in parentheses are mathematical conversions to SI units that are provided for information only and are not considered standard.

1.3 The following safety hazard caveat pertains only to the test methods portion, Section 8, of this specification: *This standard does not purport to address all of the safety concerns, if any, associated with its use. It is the responsibility of the user of this standard to establish appropriate safety, health, and environmental practices and determine the applicability of regulatory limitations prior to use.*

NOTE 1—Pipe and fittings produced to this specification should be installed in accordance with Practice D2321.

1.4 *This international standard was developed in accordance with internationally recognized principles on standardization established in the Decision on Principles for the Development of International Standards, Guides and Recommendations issued by the World Trade Organization Technical Barriers to Trade (TBT) Committee.*

2. Referenced Documents

2.1 *ASTM Standards:*²

- D618 Practice for Conditioning Plastics for Testing
- D1600 Terminology for Abbreviated Terms Relating to Plastics
- D1784 Classification System and Basis for Specification for

- Rigid Poly(Vinyl Chloride) (PVC) Compounds and Chlorinated Poly(Vinyl Chloride) (CPVC) Compounds
- D2122 Test Method for Determining Dimensions of Thermoplastic Pipe and Fittings
- D2152 Test Method for Adequacy of Fusion of Extruded Poly(Vinyl Chloride) (PVC) Pipe and Molded Fittings by Acetone Immersion
- D2321 Practice for Underground Installation of Thermoplastic Pipe for Sewers and Other Gravity-Flow Applications
- D2412 Test Method for Determination of External Loading Characteristics of Plastic Pipe by Parallel-Plate Loading
- D2444 Practice for Determination of the Impact Resistance of Thermoplastic Pipe and Fittings by Means of a Tup (Falling Weight)
- D2855 Practice for the Two-Step (Primer and Solvent Cement) Method of Joining Poly (Vinyl Chloride) (PVC) or Chlorinated Poly (Vinyl Chloride) (CPVC) Pipe and Piping Components with Tapered Sockets
- D3034 Specification for Type PSM Poly(Vinyl Chloride) (PVC) Sewer Pipe and Fittings
- D3212 Specification for Joints for Drain and Sewer Plastic Pipes Using Flexible Elastomeric Seals
- F402 Practice for Safe Handling of Solvent Cements, Primers, and Cleaners Used for Joining Thermoplastic Pipe and Fittings
- F412 Terminology Relating to Plastic Piping Systems
- F477 Specification for Elastomeric Seals (Gaskets) for Joining Plastic Pipe
- F679 Specification for Poly(Vinyl Chloride) (PVC) Large-Diameter Plastic Gravity Sewer Pipe and Fittings
- 2.2 *American Water Works Association (AWWA) Standard: AWWA Manual M45 Fiberglass Pipe Design*³
- 2.3 *Federal Standard:*
Fed. Std. No. 123 Marking for Shipment (Civil Agencies)⁴
- 2.4 *Military Standard:*
MIL-STD-129 Marking for Shipment and Storage⁴

¹ This specification is under the jurisdiction of ASTM Committee F17 on Plastic Piping Systems and is the direct responsibility of Subcommittee F17.62 on Sewer. Current edition approved April 1, 2021. Published April 2021. Originally approved in 1983. Last previous edition approved in 2014 as F794 –03(2014). DOI: 10.1520/F0794-21.

² For referenced ASTM standards, visit the ASTM website, www.astm.org, or contact ASTM Customer Service at service@astm.org. For *Annual Book of ASTM Standards* volume information, refer to the standard's Document Summary page on the ASTM website.

³ Available from American Water Works Association (AWWA), 6666 W. Quincy Ave., Denver, CO 80235, <http://www.awwa.org>.

⁴ Available from Standardization Documents Order Desk, DODSSP, Bldg. 4, Section D, 700 Robbins Ave., Philadelphia, PA 19111-5098, <http://dodssp.daps.dla.mil>.

*A Summary of Changes section appears at the end of this standard

3. Terminology

3.1 *Definitions*—Definitions are in accordance with Terminology F412, and abbreviations are in accordance with Terminology D1600, unless otherwise specified. The abbreviation for poly(vinyl chloride) is (PVC).

3.2 *Definitions of Terms Specific to This Standard:*

3.2.1 *dual wall corrugated profile (DWCP) gravity sewer pipe*—a pipe product consisting of a smooth waterway braced circumferentially with an external corrugated wall (see Fig. 1)

3.2.2 *open profile (OP) gravity sewer pipe*—a pipe product consisting of an essentially smooth waterway braced circumferentially or spirally with outside projections or ribs (see Fig. 2).

4. Significance and Use

4.1 The requirements of this specification are intended to provide pipe and fittings suitable for nonpressure drainage of sewage and surface water.

NOTE 2—Industrial waste disposal lines should be installed only with the specific approval of the governing code authority since chemicals not commonly found in drains and sewers and temperatures in excess of 140°F may be encountered.

5. Materials

5.1 *Basic Materials*—The pipe and fittings shall be made of PVC plastic having a minimum cell classification of 12454 or 12364 as defined in Specification D1784. Homopolymer PVC compounds must meet or exceed the requirements of the above listed minimum cell classification number.

5.2 *Rework Material*—Clean rework material generated from the manufacturer’s own pipe or fittings production may be used by the same manufacturer provided pipe or fittings produced meet all the requirements of this specification.

5.3 *Gaskets*—Elastomeric gaskets shall comply with the requirements described in Specification F477.

5.4 *Lubricant*—The lubricant used for assembly shall be suitable for use with PVC pipe and elastomeric seals for this application and have no detrimental effect on the gasket or on the pipe.

6. Joining Systems

6.1 *Gasketed Joint*—The integral bell gasketed joint, coupling, or fitting joints shall be designed so that when assembled, the gasket (which is attached to either the bell or the spigot) will be compressed radially on the pipe spigot or in the bell to form a water-tight seal. The joints shall be designed

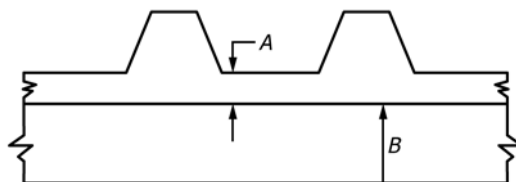

FIG. 2 Typical Open Profile (OP)

to comply with and show no sign of leakage when tested in accordance with 7.7 when assembled with pipe for which they are intended.

6.2 Couplings shall form a water-tight seal when assembled with plain end pipe and show no sign of leakage when tested in accordance with 7.7 when assembled with pipe for which they are intended.

NOTE 3—The outside diameters of products manufactured to this specification are not specified and therefore joint compatibility should be reviewed.

6.3 The joint shall be designed to avoid displacement of the gasket when assembled in accordance with the manufacturer’s recommendation.

6.4 The assembly of joints shall be in accordance with the manufacturer’s recommendations.

7. Requirements⁵

7.1 *Workmanship*—The pipe and fittings shall be essentially uniform in color, opacity, density, and other properties. The inside and outside surfaces shall be semimatte or glossy in appearance and free of chalking, sticky, or tacky material. The surfaces shall be free of excess bloom; that is, slight bloom is acceptable. The pipe walls shall be free of cracks, holes, blisters, voids, foreign inclusions, or other defects that are visible to the naked eye and that may affect the wall integrity. Bloom or chalking may develop in pipe exposed to direct rays of the sun (ultraviolet radiant energy) for extended periods and consequently these requirements do not apply to pipe after extended exposure to direct rays of the sun.

7.2 *Pipe and Fitting Dimensions:*

7.2.1 *Diameter*—The inside diameter of the pipe shall meet the requirements given in Table 1, Table 2, or Table 3 when measured in accordance with 8.4.1.

7.2.2 *Wall Thickness*—The minimum wall thickness of the waterway of pipe and fittings fabricated from pipe sections shall meet the requirements given in Table 1 for open profile; and Table 2 or Table 3 for dual wall corrugated profile pipe when measured in accordance with 8.4.2. The wall thickness of fittings fabricated from pipes meeting the requirements of Specification D3034, SDR 35 and Specification F679 are also satisfactory. Molded fittings when made with an open profile shall conform to the minimum wall thickness requirements given in Table 1.

7.2.3 *Bell Wall Thickness*—In the case of belled pipe and fittings fabricated from pipe sections, the thickness of the wall in the bell shall be considered satisfactory if it was formed

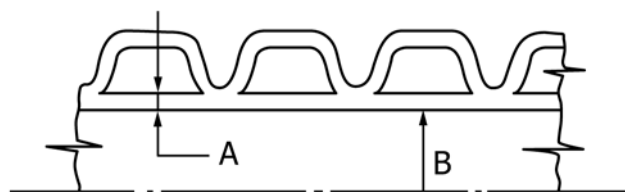

FIG. 1 Typical Dual Wall Corrugated Profile (DWCP)

⁵ Supporting data are available at ASTM Headquarters. Request RR:F17-1020.

TABLE 1 Pipe Dimensions and Stiffness (Open Profile Pipe)

Nominal Pipe Size, in.	Minimum Inside Diameter, ^A in. (mm)	Tolerance on Inside Diameter, in. (mm)	Minimum Pipe Stiffness Series 46, lbf/in. ² (kPa)	Waterway Minimum Wall Series 46, in. (mm)	Minimum Pipe Stiffness Series 10, lbf/in. ² (kPa)	Waterway Minimum Wall Series 10, in. (mm)
4	3.939(100.0)	+0.034(0.86)	46(320)	0.030(0.76)	N/A	N/A
6	5.875(149.2)	+0.049(1.24)	46(320)	0.045(1.14)	N/A	N/A
8	7.863(199.7)	+0.053(1.35)	46(320)	0.060(1.52)	N/A	N/A
10	9.825(249.6)	+0.067(1.70)	46(320)	0.070(1.78)	N/A	N/A
12	11.687(296.8)	+0.085(2.16)	46(320)	0.085(2.16)	N/A	N/A
15	14.303(363.3)	+0.116(2.95)	46(320)	0.105(2.67)	N/A	N/A
18	17.510(444.8)	+0.195(4.95)	46(320)	0.130(3.30)	10(70)	0.070(1.78)
21	20.656(524.7)	+0.200(5.08)	46(320)	0.160(4.06)	10(70)	0.085(2.16)
24	23.412(594.7)	+0.204(5.18)	46(320)	0.180(4.58)	10(70)	0.105(2.66)
27	26.371(669.8)	+0.209(5.31)	46(320)	0.205(5.22)	10(70)	0.115(2.92)
30	29.388(746.5)	+0.220(5.59)	46(320)	0.235(5.96)	10(70)	0.130(3.30)
33	32.405(823.1)	+0.227(5.77)	46(320)	0.260(6.60)	10(70)	0.150(3.81)
36	35.370(898.4)	+0.235(5.97)	46(320)	0.290(7.36)	10(70)	0.165(4.20)
39	38.380(974.9)	+0.245(6.22)	46(320)	0.315(8.00)	10(70)	0.195(4.95)
42	41.370(1050.8)	+0.255(6.48)	46(320)	0.345(8.76)	10(70)	0.215(5.46)
45	44.365(1126.9)	+0.265(6.73)	46(320)	0.370(9.40)	10(70)	0.225(5.72)
48	47.355(1202.8)	+0.285(7.24)	46(320)	0.400(10.16)	10(70)	0.230(5.84)

^A In-plant quality control manufacturing. Base inside diameter calculations should include out-of-roundness as a result of shipping and handling.

TABLE 2 Pipe Dimensions and Stiffness (Dual Wall Corrugated) Pipe for Series 46 and Series 10

Nominal Pipe Size, in.	Minimum Inside Diameter, in. (mm)	Tolerance on Inside Diameter, in. (mm)	Minimum Pipe Stiffness Series 46, lbf/in. ² (kPa)	Waterway Minimum Wall Series 46, in. (mm)	Minimum Pipe Stiffness Series 10, lbf/in. ² (kPa)	Waterway Minimum Wall Series 10, in. (mm)
4	3.939(100.0)	+0.034(0.86)	46(320)	0.022(0.56)	N/A	N/A
6	5.875(149.2)	+0.049(1.24)	46(320)	0.025(0.64)	N/A	N/A
8	7.863(199.7)	+0.053(1.35)	46(320)	0.035(0.89)	N/A	N/A
10	9.825(249.6)	+0.067(1.70)	46(320)	0.045(1.14)	N/A	N/A
12	11.687(296.8)	+0.085(2.16)	46(320)	0.058(1.40)	N/A	N/A
15	14.303(363.3)	+0.116(2.95)	46(320)	0.077(1.96)	N/A	N/A
18	17.510(444.8)	+0.195(4.95)	46(320)	0.084(2.13)	10(70)	0.070(1.78)
21	20.656(524.7)	+0.200(5.08)	46(320)	0.095(2.41)	10(70)	0.070(1.78)
24	23.412(594.7)	+0.204(5.18)	46(320)	0.110(2.79)	10(70)	0.070(1.78)
27	26.371(669.8)	+0.209(5.31)	46(320)	0.120(3.05)	10(70)	0.070(1.78)
30	29.388(746.5)	+0.220(5.59)	46(320)	0.130(3.30)	10(70)	0.085(2.16)
33	32.405(823.1)	+0.227(5.77)	46(320)	0.150(3.81)	10(70)	0.095(2.41)
36	35.370(898.4)	+0.235(5.97)	46(320)	0.155(3.94)	10(70)	0.105(2.67)
39	38.380(974.9)	+0.245(6.22)	46(320)	0.200(5.08)	10(70)	0.120(3.05)
42	41.370(1050.8)	+0.255(6.48)	46(320)	0.200(5.08)	10(70)	0.130(3.30)
45	44.365(1126.9)	+0.265(6.73)	46(320)	0.200(5.08)	10(70)	0.145(3.68)
48	47.355(1202.8)	+0.285(7.24)	46(320)	0.200(5.08)	10(70)	0.160(4.06)

TABLE 3 Pipe Dimensions and Stiffness (Dual Wall Corrugated) Pipe for Series 115

Nominal Pipe Size, in.	Minimum Inside Diameter, in. (mm)	Tolerance on Inside Diameter, in. (mm)	Minimum Pipe Stiffness Series 115, lbf/in. ² (kPa)	Waterway Minimum Wall Series 115, in. (mm)
8	7.692 (195.4)	+0.053 (1.35)	115 (800)	0.037 (0.94)
10	9.623 (244.4)	+0.067 (1.70)	115 (800)	0.046 (1.30)
12	11.452 (290.9)	+0.085 (2.16)	115 (800)	0.070 (1.78)
15	13.998 (355.5)	+0.116 (2.95)	115 (800)	0.092 (2.34)

from pipe meeting the above requirements. For reducing fittings or those with smaller inlets, the minimum wall thickness for each inlet shall be no less than the minimum wall thickness for that size pipe.

7.2.4 Fittings:

7.2.4.1 *Molded Fittings*—Molded fittings conforming to the requirements of Specification **D3034**, SDR 35 may also be

used with profile gravity sewer pipe provided an adaptor (when required) is used to make the connection. The minimum wall thickness of the molded fittings and adaptors shall coincide with the values listed in Table 1 of Specification **D3034** for SDR 35. The thickness in the wall of the adaptor bell shall be considered satisfactory if formed from pipe meeting the above requirements. When a molded fitting is used to join different types of plastic pipes, the bell and the body or branch area extending from the bell shall also conform to the minimum wall thickness and profile of the pipe being installed into the bell.

7.2.4.2 *Fabricated Fittings*—Fabricated fittings shall be made from pipe meeting the requirements of this specification, Specification **D3034**, SDR 35, or Specification **F679**. Fabricated fittings with solvent cement components shall be made in accordance with Practice **D2855** and taking cognizance of Practice **F402**. Unreinforced solvent cement mitred joints shall not be used. Fabricated joints shall be adequately lapped or fusion butt welded and, when needed additionally reinforced.

NOTE 4—A fabricated fittings standard is currently being developed by

ASTM Subcommittee F 17.10.

7.3 Pipe Flattening—There shall be no evidence of splitting, cracking, breaking, or separation of ribs, seams, or corrugations, when pipe is tested in accordance with **8.5**.

7.4 Pipe Impact Strength—The impact strength shall not be less than the values shown in **Table 4** when tested in accordance with **8.6**.

NOTE 5—This requirement is intended only for use as a quality control test, not as a simulated service test. Aged impact data are currently under study by an ASTM Committee F17 task group.

7.5 Pipe Stiffness—Pipe stiffness values shall comply with **Table 1**, **Table 2**, or **Table 3** for the respective pipe series when tested in accordance with **8.7**.

7.6 Gaskets—Gaskets shall meet the low head application requirements of Specification **F477** and be molded into a circular form or extruded to the proper section and then spliced into circular form.

7.7 Joint Tightness—All joints shall show no signs of leakage when tested in accordance with Specification **D3212** and **Fig. 3**. Some grades of pipe may not have the capability in the pipe wall of withstanding the 22 in. Hg vacuum test. In such cases, the joint may be considered as meeting these criteria if a pipe and joint system, incorporating a geometrically identical joint and heavier walled pipe, meets the criteria satisfactorily. All surfaces of the joint upon which the gasket may bear shall be smooth and free of imperfections, ridges, fractures, or cracks that could adversely affect sealability.

7.8 Acetone Immersion—The pipe shall meet the requirements as defined in Test Method **D2152** when tested in accordance with **8.8**.

7.8.1 Bond—The bond between the inner and outer walls (at the corrugation valley) shall not separate when tested in accordance with **8.8.1**.

NOTE 6—This is intended only for use as a quality control test and not for use as a simulated service test.

7.9 Air Test—When pipe is made in such a manner that a seam is present, each length shall pass a 3.5-psi air test in accordance with **8.9**.

8. Test Methods

8.1 Conditioning:

8.1.1 Referee Testing—When conditioning is required for referee tests, condition the specimens in accordance with Procedure A of Practice **D618** at $73.4\text{ }^{\circ}\text{F} \pm 3.6\text{ }^{\circ}\text{F}$ ($23\text{ }^{\circ}\text{C} \pm 2\text{ }^{\circ}\text{C}$) and $50 \pm 10\%$ relative humidity for not less than 40 h prior to test. Conduct tests under the same conditions of temperature and humidity, unless otherwise specified.

8.1.2 Quality Control Testing—Condition specimens for a minimum of 4 h in air or 1 h in water at $73.4\text{ }^{\circ}\text{F} \pm 3\text{ }^{\circ}\text{F}$ ($23\text{ }^{\circ}\text{C} \pm 2\text{ }^{\circ}\text{C}$). Test the specimens at $73.4\text{ }^{\circ}\text{F} \pm 3\text{ }^{\circ}\text{F}$ without regard to relative humidity.

8.2 Test Conditions—Conduct tests in the standard laboratory atmosphere of $73.4\text{ }^{\circ}\text{F} \pm 3.6\text{ }^{\circ}\text{F}$ ($23\text{ }^{\circ}\text{C} \pm 2\text{ }^{\circ}\text{C}$) and $50 \pm 10\%$ relative humidity, unless otherwise specified in the test methods or in this specification. In cases of disagreement, the tolerances shall be $\pm 1.8\text{ }^{\circ}\text{F}$ ($\pm 1\text{ }^{\circ}\text{C}$) and $\pm 2\%$ relative humidity.

8.3 Sampling—The selection of the samples of pipe shall be as agreed upon between the purchaser and the seller. In case of no prior agreement, any sample selected by the testing laboratory shall be deemed adequate.

8.4 Dimensions:

8.4.1 Inside Diameter—Determine the average inside diameter using an internal micrometer or telescoping gage accurate to $\pm 0.001\text{ in.}$ ($\pm 0.02\text{ mm}$). Take sufficient readings, a minimum of four, to ensure that the maximum and minimum have been determined. Calculate the average diameter as the arithmetic mean of the diameters measured. As an alternative method, an inside-diameter-type circumferential tape may be used if proper care is taken to align it at right angles to the pipe axis. A tapered plug gage as described in Test Method **D2122** may also be used.

8.4.2 Wall Thickness—Measure the wall thickness of the thinnest cross section of the waterway in the gaps between ribs; and between the valleys under the corrugations in accordance with Test Method **D2122**. Make sufficient readings, a minimum of eight, to ensure that the minimum thickness has been determined. (See **Tables 1-3**.)

8.5 Flattening—Flatten three specimens of pipe between parallel plates until the distance between the plates, expressed as a % of the inside pipe diameter is reduced by the greater of 40 % or of the value as determined by $[2.09\text{ (OD)/(OD-ID)}]$ for pipes with 10 psi minimum pipe stiffness, of the value as determined by $[3.43\text{ (OD)/(OD-ID)}]$ for pipes with a 46 psi minimum pipe stiffness or of the value as determined by $[4.62\text{ (OD)/(OD-ID)}]$ for pipes with a 115 psi minimum pipe stiffness. Prior to running the test, the pipe OD must be determined by measuring in accordance with Test Method **D2122**, using a circumferential wrap tape accurate to $\pm 0.001\text{ in.}$ ($\pm 0.02\text{ mm}$).

NOTE 7—The amount of flattening required in **8.5** develops bending strains at least as great as those developed when flattening DR 35 pipe by 60 % (see **Appendix X1**).

8.5.1 The rate of loading shall be uniform and such that the compression is completed within 2 to 5 min. The specimens shall pass if no splitting, cracking, breaking, or separation of ribs, seams or corrugations is observed under normal light with the unaided eye. Small tears initiated at the cut end of the rib shall not constitute failure. The specimen shall be considered as failing this test if the load does not increase continuously (or smoothly) with increasing deflection to the point of maximum load. The maximum load point shall not be at less than 30 % deflection.

TABLE 4 Minimum Impact Strength, 73°F (23°C)

Nominal Size, in.	Impact Strength, ft-lbf (J)
4	100 (136)
6	140 (190)
8	210 (284)
10 to 48	220 (299)

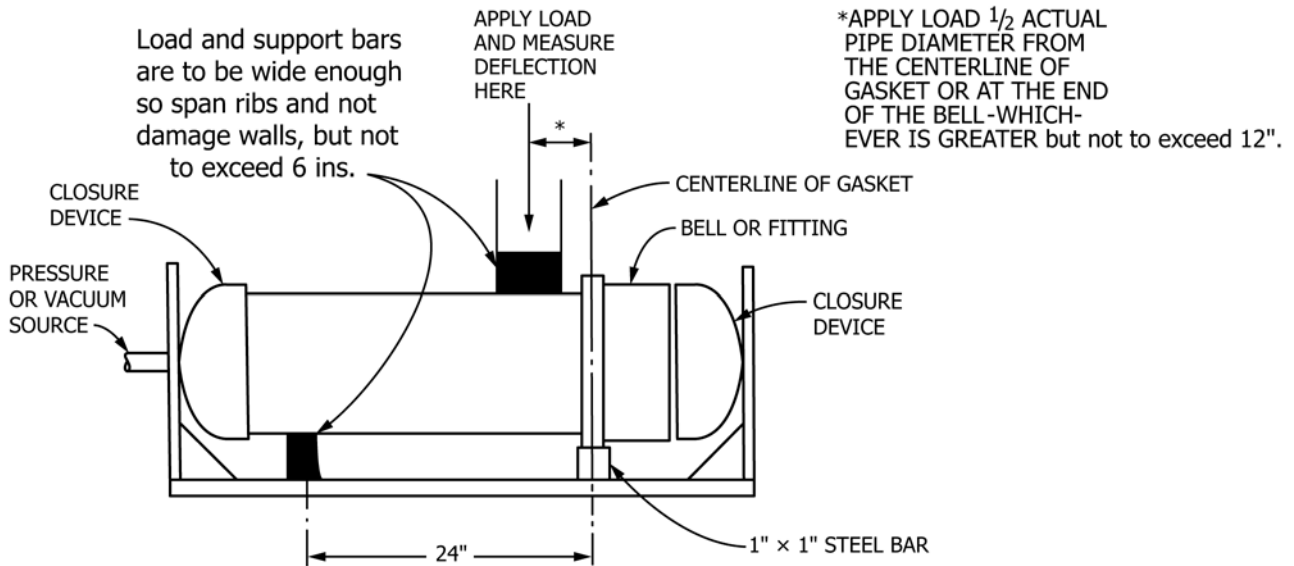

FIG. 3 Shear Deflection Test

8.5.2 Test specimens shall be 6 in. (152 mm) long when testing 4 in. through 15 in., and 12 in. (305 mm) long when testing 18 in. or larger.

8.6 *Impact Resistance*—Determine the impact resistance of the pipe in accordance with conditions and apparatus in Test Method D2444. Impact tests shall be conducted at three different locations where possible. The three locations are (1) directly on the rib or corrugation so that one of the ribs or corrugations receives the impact essentially centered on the top face; (2) directly on the pipe midway between ribs or corrugations (when physical spacing of the ribs or corrugations does not allow a direct hit, this orientation is omitted); and (3) directly on the seam. (Where a seam cannot be struck directly, this orientation is omitted.) Failure of the test specimen shall be any crack, split, or shattering of the waterway. Separation of ribs or corrugations from the waterway or seams constitutes a failure.

NOTE 8—Small tears observable after tests may be up to approximately 10 % of the nominal diameter in length.

NOTE 9—Test a total of six specimens, with two specimens at each orientation. Where one or more orientations are omitted, the six specimens are divided equally between the remaining test orientations.

NOTE 10—If a rib is chipped by an indirect hit, the specimen may be replaced in the test.

8.6.1 In sizes 4 in. through 48 in., test six specimens, using a 20-lb (9-kg) Tup B or a 30-lb. (15-kg) Tup B and flat plate Holder B. Specimens shall be a minimum of 6 in. long, such that the specimens are cut midway between the ribs or corrugations and contain an odd number of ribs or corrugations. All six specimens shall pass. If one fails, test another six specimens. Eleven passes out of twelve tested shall be acceptable.

8.7 *Pipe Stiffness*—Determine the pipe stiffness at 5 % deflection datum in accordance with Test Method D2412. The pipe stiffness of each specimen tested shall equal or exceed the minimum value listed in Table 1, Table 2, or Table 3.

8.7.1 Three specimens are to be run per test. The length of the specimens are specified in Table 5. Circumferentially ribbed test specimens must be selected so that they are representative of the entire pipe. Select a specimen length 6 in. or greater, depending on pipe size (see Table 5), such that the specimens both begin and terminate midway between ribs. Dual wall corrugated pipe specimens shall be cut in the valley, between corrugations.

NOTE 11—A representative stiffness specimen contains the proper ratio of ribs and flat area lengths to exhibit the entire pipe length. When properly selected, specimens cut consecutively from a pipe length and untrimmed will provide stiffness results that are approximately equal.

NOTE 12—The 5 % deflection criterion, which was arbitrarily selected for testing convenience, should not be considered as a limitation with respect to in-use deflection. The engineer is responsible for establishing the acceptable deflection limit.

8.8 *Acetone Immersion*—Conduct this test in accordance with Test Method D2152. This procedure is used for determining the degree of fusion of extruded PVC plastic pipe as indicated by reaction to immersion in anhydrous acetone. It is applicable only for distinguishing between unfused and properly fused PVC.

8.8.1 *Bond for DWC Pipe*—Test the bond between the inner and outer wall with a probe or knife point. It shall not be possible to cleanly separate the two walls at the corrugation valley. Test samples at eight equally spaced joints around its circumference.

8.9 *Air Test*—Test each full length of pipe for air tightness at 3.5 psig (24.1 kPa) for the minimum dwell period specified in Table 5.

TABLE 5 Specimen Size for Pipe Stiffness

Pipe Configuration	Pipe Diameter, in.	
	4 to 15	18 to 48
Circumferential	6 min	12 min
Helical	6 or one full wrap, whichever is larger	12 or one full wrap, whichever is larger