



Standard Guide for Construction of Sounding Tube and Striker Plate for Tank Sounding¹

This standard is issued under the fixed designation F1386; the number immediately following the designation indicates the year of original adoption or, in the case of revision, the year of last revision. A number in parentheses indicates the year of last reapproval. A superscript epsilon (ϵ) indicates an editorial change since the last revision or reapproval.

1. Scope

1.1 This guide covers design and construction criteria for striker plates and sounding tubes, excluding deck penetrations and caps, for use with sounding rods or tapes in freshwater, saltwater, and oil tanks.

1.2 The values stated in inch-pound units are to be regarded as standard. The values given in parentheses are mathematical conversions to SI units that are provided for information only and are not considered standard.

1.3 *This standard does not purport to address all of the safety concerns, if any, associated with its use. It is the responsibility of the user of this standard to establish appropriate safety, health, and environmental practices and determine the applicability of regulatory limitations prior to use.*

1.4 *This international standard was developed in accordance with internationally recognized principles on standardization established in the Decision on Principles for the Development of International Standards, Guides and Recommendations issued by the World Trade Organization Technical Barriers to Trade (TBT) Committee.*

2. Referenced Documents

2.1 ASTM Standards:²

- A36/A36M Specification for Carbon Structural Steel
- A53/A53M Specification for Pipe, Steel, Black and Hot-Dipped, Zinc-Coated, Welded and Seamless
- F722 Specification for Welded Joints for Shipboard Piping Systems
- F1155 Practice for Selection and Application of Piping System Materials

¹ This guide is under the jurisdiction of ASTM Committee F25 on Ships and Marine Technology and is the direct responsibility of Subcommittee F25.11 on Machinery and Piping Systems.

Current edition approved April 15, 2021. Published April 2021. Originally approved in 1992. Last previous edition approved in 2016 as F1386 – 92 (2016) ^{ϵ 1}. DOI: 10.1520/F1386-92R21.

² For referenced ASTM standards, visit the ASTM website, www.astm.org, or contact ASTM Customer Service at service@astm.org. For *Annual Book of ASTM Standards* volume information, refer to the standard's Document Summary page on the ASTM website.

2.2 ASME Standards:³

- ASME B16.5 Pipe Flanges and Flanged Fittings: NPS 1/2 through NPS 24 Metric/Inch Standard
- ASME B16.9 Factory-Made Wrought Butt Welding Fittings
- ASME B16.11 Forged Fittings, Socket-Welding and Threaded
- ASME B16.28 Wrought Steel Butt Welding Short Radius Elbows and Returns
- ASME B31.1 Power Piping

2.3 ABS Standard:⁴

- ABS Rules for Building and Classing Steel Vessels

2.4 AWS Standard:⁵

- AWS D1.1 Structural Welding Code

3. Terminology

3.1 Definitions of Terms Specific to This Standard:

- 3.1.1 *external sounding tube, n*—a sounding tube located outside the boundaries of the tank being sounded.
- 3.1.2 *internal sounding tube, n*—a sounding tube located inside the tank being sounded.
- 3.1.3 *sounding, n*—measurement by sounding; a place or part of a body of liquid where a hand sounding line will reach bottom.

4. Classification

- 4.1 *Type I*—Internal sounding tube, with separate striker plate.
- 4.2 *Type II*—Internal sounding tube, with attached striker plate.
- 4.3 *Type III*—Internal sounding tube, with angle striker plate.
- 4.4 *Type IV*—External sounding tube.

³ Available from American Society of Mechanical Engineers (ASME), ASME International Headquarters, Two Park Ave., New York, NY 10016-5990, <http://www.asme.org>.

⁴ Available from American Bureau of Shipping (ABS), ABS Plaza, 1701 City Plaza Dr., Spring, TX 77389, <http://www.eagle.org>.

⁵ Available from American Welding Society (AWS), 8669 NW 36 St., #130, Miami, FL 33166-6672, <http://www.aws.org>.

5. Significance and Use

5.1 Sounding tubes may be fabricated from 1½ NPS or larger. Only when otherwise specified, Schedule 40 components, manufactured from the list of material indicated in Practice F1155 and Specification A53/A53M, Grade S or Grade ERW. In addition, sounding tubes may be fabricated in stainless steel for stainless steel tanks.

5.1.1 Sounding tubes passing through or terminating in fuel tanks, potable water tanks, or clean salt water ballast tanks should be constructed of 70-30 copper nickel, but other suitable material is acceptable.

5.2 Striker plates shall be fabricated in accordance with Specification A36/A36M.

5.3 The fittings shall be designed in accordance with ASME B16.5, ASME B16.9, ASME B16.28, or ASME B16.11 as applicable (see Table 21 in Practice F1155), and the installation shall be in accordance with ASME B31.1 as modified by Specification F722. These standards cover the fitting tolerances.

5.4 Some cargo may preclude the use of materials specified in this guide. However, configuration examples are applicable for all applications.

5.5 When a sounding tube is combined with the air escape, either three 1¼-in. (approximately 30-mm) diameter holes approximately 12 in. (305 mm) from the tank top equally spaced or six ½-in. (approximately 15-mm) diameter holes approximately 6 in. (150 mm) from the tank top equally spaced can be used for perforations. See Fig. 2.

5.6 Figs. 1-4 are guidance details.

6. Installation of Sounding Tubes

6.1 Locate sounding tubes as close as possible to the lowest part of the tank.

6.2 Type I, II, and III sounding tubes, excluding oil products, shall be perforated as shown in Fig. 1, Fig. 2, and Fig. 3 respectively, for ventilation.

6.2.1 Type IV sounding tubes are only allowed where the tank cannot be penetrated from the top because of an unavoidable situation, such as a prohibitive location (see Fig. 4).

6.3 Slope and curvature shall be kept to a minimum, and under no circumstances shall the slope be permitted to exceed 45° from the vertical. Radius of curvatures up to a minimum of 10 ft (approximately 3 m) will be permitted where unavoidable.

6.4 Tubes may be provided with flanged take down connections, approximately 18 in. (455 mm) from the tank bottom.

6.4.1 Tubes shall be terminated close enough to tank bottoms to prevent hangup of a sounding device or a thief sampler when they are being withdrawn from a tank.

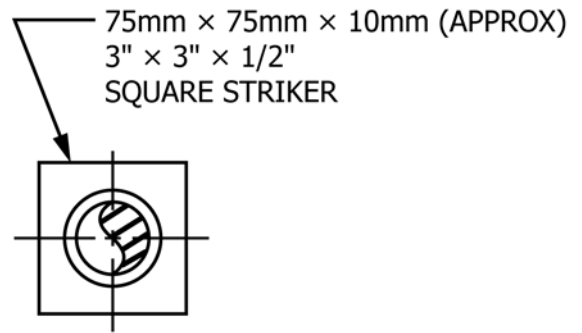

SECTION "A-A"

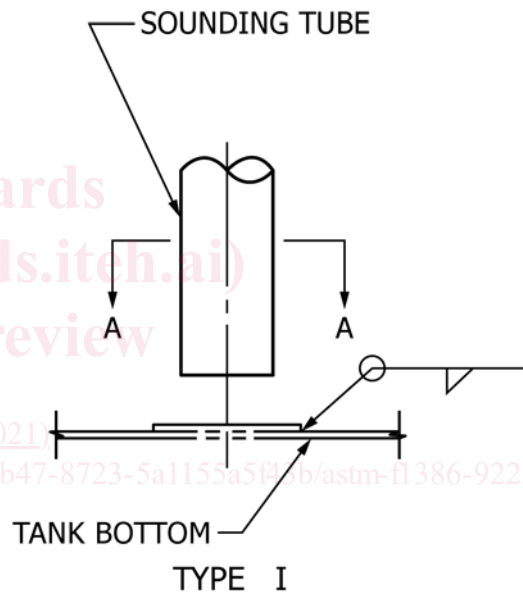

FIG. 1 Type I Sounding Tube

6.4.2 The inside edges of sounding tube shall be smoothed to prevent hanging up of a sounding device or thief sampler when they are being withdrawn from the tank.

6.5 Tubes shall be adequately supported to withstand both static and dynamic loads.

6.6 Welding shall be in accordance with ABS Rules for Building and Classing Steel Vessels or AWS D1.1.

7. Keywords

7.1 sounding; sounding tube; tank

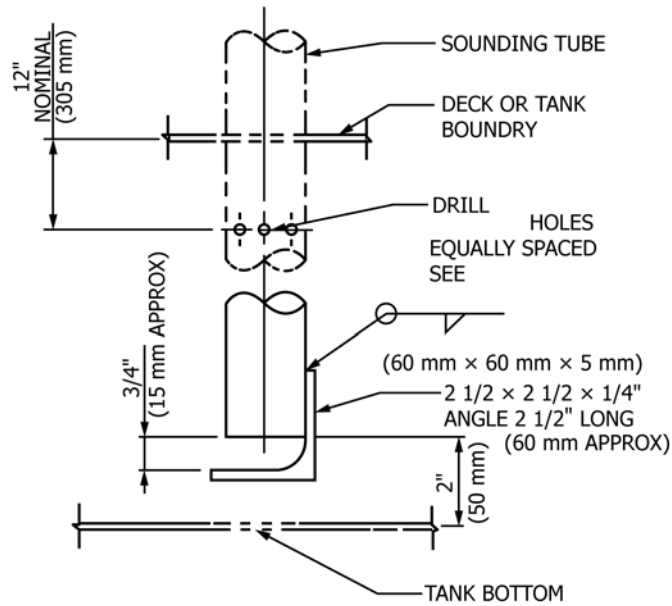

TYPE II

FIG. 2 Type II Sounding Tube

60mm x 60mm x 5mm (APPROX)
 2 1/2" x 2 1/2" x 1/4"
 ANGLE 2 1/2" LONG
 60 mm (APPROX)

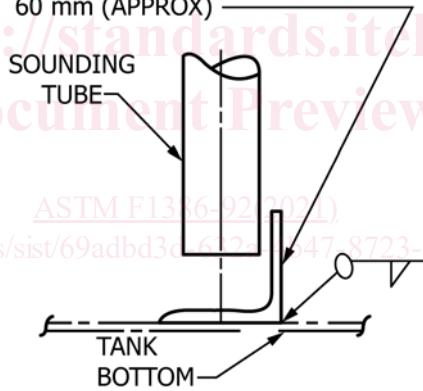

FIG. 3 Type III Sounding Tube