



Designation: **F2657–07 (Reapproved 2018) F2657 – 21**

Standard Test Method for Outdoor Weathering Exposure of Crosslinked Polyethylene (PEX) Tubing¹

This standard is issued under the fixed designation F2657; the number immediately following the designation indicates the year of original adoption or, in the case of revision, the year of last revision. A number in parentheses indicates the year of last reapproval. A superscript epsilon (ϵ) indicates an editorial change since the last revision or reapproval.

1. ~~Scope~~ Scope*

1.1 This test method describes the procedure for exposing crosslinked polyethylene (PEX) tubing produced in accordance with Specification **F876** to natural (sunlight) ultraviolet (UV) radiation and evaluating the effects of the exposure. This test method outlines the requirements for specimen size and preparation, exposure orientation, minimum UV exposure energy, post exposure testing and reporting.

NOTE 1—While other laboratory UV exposure systems are available, this test method relies on natural sunlight as the UV radiation source. Laboratory methods may be added in the future if testing confirms a correlation between natural sunlight and laboratory exposure.

1.2 PEX tubing is not designed for outdoor use. Data from short-term exposure testing per this test method can be used to judge the relative performance of PEX tubing stored outdoors for short periods of time prior to installation completely shielded from sunlight.

1.3 The values stated in SI units are to be regarded as standard. No other units of measurement are included in this standard.

1.4 The following precautionary caveat pertains only to the test method and post exposure testing portions, Sections 8 and 9 of this test method. *This standard does not purport to address all of the safety concerns, if any, associated with its use. It is the responsibility of the user of this standard to establish appropriate safety, health, and environmental practices and determine the applicability of regulatory limitations prior to use.*

1.5 *This international standard was developed in accordance with internationally recognized principles on standardization established in the Decision on Principles for the Development of International Standards, Guides and Recommendations issued by the World Trade Organization Technical Barriers to Trade (TBT) Committee.*

2. Referenced Documents

2.1 ASTM Standards:²

- D1435 Practice for Outdoor Weathering of Plastics
- D1598 Test Method for Time-to-Failure of Plastic Pipe Under Constant Internal Pressure
- D1600 Terminology for Abbreviated Terms Relating to Plastics
- F412 Terminology Relating to Plastic Piping Systems
- F876 Specification for Crosslinked Polyethylene (PEX) Tubing

¹ This test method is under the jurisdiction of ASTM Committee F17 on Plastic Piping Systems and is the direct responsibility of Subcommittee F17.40 on Test Methods. Current edition approved Aug. 1, 2018; May 1, 2021. Published August 2018; May 2021. Originally approved in 2007. Last previous edition approved in 2012 as F2657-07(2012); F2657-07(2018). DOI: 10.1520/F2657-07R18; 10.1520/F2657-21.

² For referenced ASTM standards, visit the ASTM website, www.astm.org, or contact ASTM Customer Service at service@astm.org. For *Annual Book of ASTM Standards* volume information, refer to the standard's Document Summary page on the ASTM website.

*A Summary of Changes section appears at the end of this standard

F2023 Test Method for Evaluating the Oxidative Resistance of Crosslinked Polyethylene (PEX) Pipe, Tubing and Systems to Hot Chlorinated Water
G147 Practice for Conditioning and Handling of Nonmetallic Materials for Natural and Artificial Weathering Tests

3. Terminology

3.1 *Definitions*—Definitions are in accordance with Terminology **F412** and abbreviations are in accordance with Terminology **D1600**, unless otherwise indicated.

3.2 *Definitions of Terms Specific to This Standard:*

3.2.1 *nominal exposure time period, n*—the number of months corresponding to the measured TUV as defined in **Table 1**.

3.2.2 *polar orientation, n*—the longitudinal direction of the specimens with respect to the Equator.

3.2.3 *solar UV radiation, n*—the portion of the light spectrum falling within the range of 295nm to 385nm.

3.2.4 *total solar UV radiation (TUV), n*—the sum of measured UV Energy for the time period specimens are exposed, expressed in MJ/m². The historical average monthly TUV values for Central Arizona, 5° off horizontal exposure are listed in **Table 1**.

3.2.5 *tubing bow, n*—the resultant curvature of a tubing sample taken from a coil.

3.2.6 *UV energy, n*—the amount of solar UV radiation per unit time based on a 5° off horizontal specimen placement for Central Arizona expressed as MJ/m².

3.2.6.1 *Discussion*—

UV Energy for Central Arizona was selected as it represents the worst case North American location based on a 4-year average of 1998 through 2001. This information was provided by Atlas Material Testing Technology LLC.

4. Summary of Test Method

4.1 PEX tubing specimens are exposed to solar UV radiation for a period of time and then removed. The exposed specimens are then tested in accordance with one of the following methods:

4.2 *Potable Water Applications*—UV exposed specimens are tested at one temperature and pressure condition in accordance with Test Method **F2023** to determine the average time to failure. The average time to failure for the UV-exposed specimens is then compared to the average time to failure of non UV-exposed specimens of the same PEX material or to the predicted time to failure for the same material based on a complete Test Method **F2023** data set. The percentage decrease in the average time to failure for the UV exposed specimens and the TUV of the exposure are reported.

4.3 *Non-Potable Water Applications*— PEX tubing for non-potable water applications is post-exposure tested in accordance with

TABLE 1 Total UV (TUV) Energy per Monthly Time Period^A

Nominal Exposure Time Period	TUV Solar Radiation MJ/m ²	Highest Consecutive UV Month Range
1 month	40	June
2 months	80	May-June
3 months	119	May-July
4 months	154	May-August
5 months	187	April-August
6 months	218	April-September
7 months	246	March-September
8 months	270	March-October
9 months	289	February-October
10 months	307	February-November
11 months	324	January-November
12 months	339	January-December

^ASolar Solar UV radiation is based on Central Arizona 5° off horizontal for the 4 year period of 1998 through 2001 as reported by Atlas and Testing and Technology LLC.

4.2 or, alternately, tested in accordance with the stabilizer functionality test in Specification F876. The pass or fail result of the stabilizer functionality test and the TUV of the exposure are reported.

5. Significance and Use

5.1 During shipment, storage and installation, PEX tubing may be exposed to UV radiation prior to being shielded from further exposure after installation. The effects of UV exposure on PEX tubing is determined by use of this test method. By first exposing specimens to solar UV radiation and subsequently testing specimens for oxidative resistance or stabilizer functionality, changes as a result of solar UV radiation exposure can be evaluated. This information can be used to determine the maximum allowable total UV exposure prior to permanent shielding provided by installation.

5.2 The results of short-term exposure tests can provide an indication of relative outdoor performance, but they should not be used to predict the absolute long-term performance of a material. The results of tests conducted for less than twelve months will depend on the particular season of the year in which they begin.

6. Apparatus

6.1 *Test Site*—Exposure site shall be in accordance with Practice D1435 and shall be in a hot, dry climate (for example, Phoenix, AZ).

6.2 *Specimen Rack*—Specimen racks shall be in accordance with Practice D1435 and shall allow for vertical mounting of samples free of torsional or tensile stress. The rack shall position the exposed surface of the specimens at a tilt angle in the range of 5° to 45° inclusive.

6.3 *Backing*—specimens shall be tested un-backed.

6.4 *UV Energy Measurement Equipment*—UV radiation shall be measured using an Ultraviolet Radiometer conforming to the requirements of Practice D1435. Radiometer shall be mounted in the same attitude as the exposed samples.

7. Sampling and Specimen Preparation

7.1 *Sampling*—specimens shall be representative of the product/material being evaluated. Select a sufficient amount of tubing to satisfy the testing requirements. Specimens can be straight or can have a bow when cut from a coil.

7.2 *Test Specimen Size—Length*—PEX tubing specimens shall be of nominal size a minimum of ½ in., SDR 9, and shall be a minimum of 380 mm (15.380 mm (15 in.) in length for nominal tubing sizes up to and including 1 in. and 457 mm (18 in.) in length for nominal tubing sizes 1¼ in. and above for the UV exposure portion of this method.

NOTE 2—These specimen lengths are specified so that there is a minimum of 305 mm to 457 mm in length between fitting closure distance in accordance with 7.2 of Test Method F2023.

7.2.1 Size restriction—When testing is performed on NTS ½ tubing, the testing will qualify all tubing sizes. When testing is performed on nominal tubing sizes larger than ½, the UV classification shall only apply for the size tested and larger.

NOTE 3—For example, when testing is performed on NTS 1, the testing will only qualify sizes 1 and larger.

7.3 Number of Test Specimens:

7.3.1 *Post Exposure Testing to Test Method F2023*—when a complete data set exists for the PEX material being evaluated to Test Method F2023 and that data will be used for calculation in accordance with 10.4, a minimum of five specimens are required. When no data set exists for the PEX material being evaluated to Test Method F2023, or the existing data set will not be used for calculation in accordance with 10.4, a minimum of ten specimens are required, five for UV exposure and five for the non UV-exposed portion of this method.

7.3.2 *Post-Exposure Testing to Stabilizer Functionality* — a minimum of six specimens are required when stabilizer functionality is used for post UV exposure testing.

NOTE 4—The minimum specimen requirements are based on a single Nominal Exposure Time Period (NETP) for the material being evaluated. When the expected NETP for the material is unknown, additional specimens may be UV exposed for various levels of NETP and post-exposure test data can be evaluated against non-UV exposed data.

8. Procedure

8.1 *Required Specimens*—obtain sufficient specimens in accordance with Section 7.

8.2 *Preparation*—condition and prepare specimens in accordance with Practice G147 prior to exposure testing. Samples to be used for non-UV exposed testing, when required, shall be shielded from any UV exposure source (for example, sunlight, fluorescent lighting, HID lamps, etc.) with opaque covering.

8.3 *Mounting Specimens for UV Exposure:*

8.3.1 *Polar Orientation*—position specimens in the North-South orientation with respect to the Equator. See Fig. 1.

8.3.2 *Mounting*— mount specimens on the specimen rack vertically free of torsional or tensile stress.

8.3.3 *Tubing Bow*—bowed specimens, such as those cut from a coil, shall be positioned with the crown of the bow $90^\circ \pm 5^\circ$ to the plane of the rack. The crown may be positioned in the up or the down position. All bowed specimens in a rack shall be bowed in the same direction either outward or inward relative to the plane of the rack. See Fig. 2. Tubing orientation shall not permit containment of water.

8.3.4 *Markings Positioning*—any print lines, markings or stripes shall be positioned so that no portion of them lie within the region of $\pm 45^\circ$ from the vertical axis centerline (top dead center). See Fig. 3.

8.4 *UV Exposure*—Expose specimens. Once the desired TUV in accordance with Table 1 is achieved remove specimens.

NOTE 5—Since each PEX compound will have different resistance to UV exposure, exposure at several TUV levels may be required to determine the maximum TUV that can be tolerated by the particular compound being evaluated.

8.5 *Handling Exposed Specimens*—exposed specimens shall be handled in accordance with G147. Exposed specimens shall be shielded from any UV exposure source (for example, sunlight, fluorescent lighting, HID lamps, etc.) with opaque covering.

9. Post UV-Exposure Testing

9.1 Test UV-Exposed Specimens generated in Section 8 to either 9.2 or 9.3. When required, test non UV-exposed specimens in accordance with 9.4.

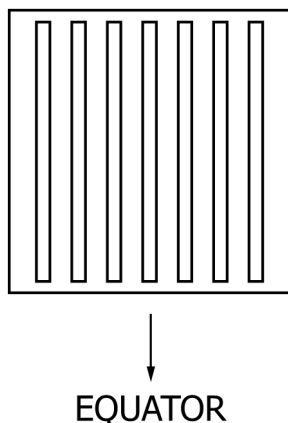

FIG. 1 North-South Polar Orientation

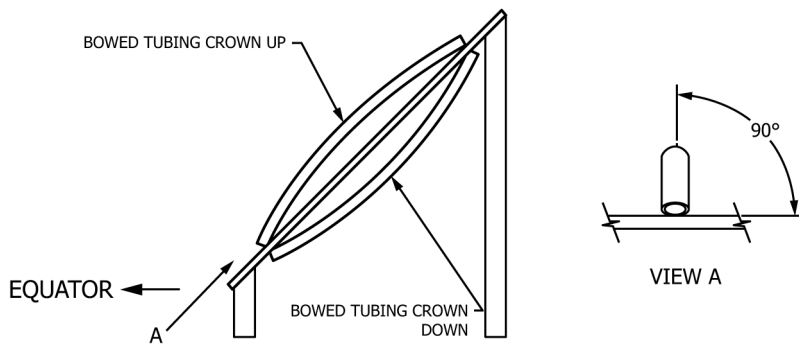

FIG. 2 Bowed Tubing Racking

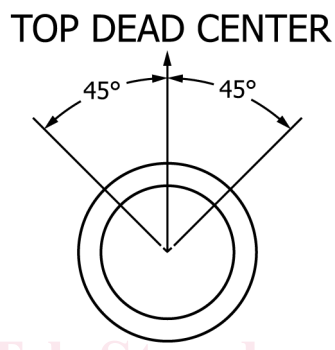

FIG. 3 Top Dead Center

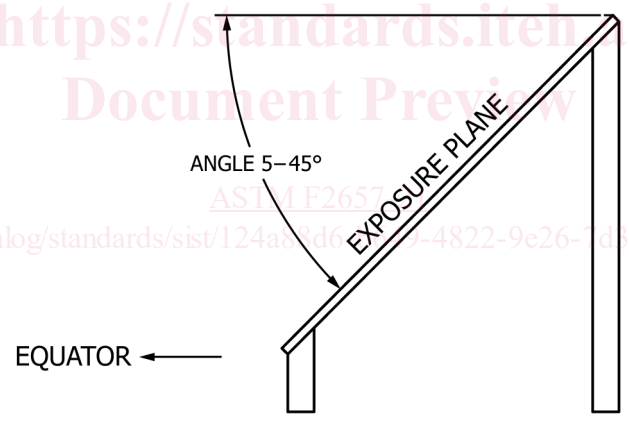

FIG. 4 Exposure Plane Angle

9.2 *Oxidative Resistance Testing to Test Method F2023*—test the exposed specimens at one temperature and pressure condition in accordance with Test Method F2023. Test all specimens to failure. All failures shall be Stage III brittle oxidative failures. See Specification F876.

NOTE 6—The selection of the temperature and pressure for post-exposure oxidative resistance testing is not critical. However, testing at a higher temperature will reduce the test duration. When a data set in accordance with Test Method F2023 exists for the PEX tubing being evaluated, selecting a temperature and pressure condition of that data set is preferred so that the effects of UV exposure can be directly calculated.

9.3 *Stabilizer Functionality Testing to Specification F876*—test a minimum of six UV-exposed specimens in accordance with the stabilizer functionality section of Specification F876.

9.4 *Non UV-Exposed Specimen Testing*— When no data set in accordance with Test Method F2023 exists for the PEX tubing being evaluated, or when an existing data will not be used to evaluate the effects of UV exposure, test a minimum of five non UV-exposed