



Designation: **D5633–04 (Reapproved 2016) D5633 – 21**

## Standard Practice for Sampling with a Scoop<sup>1</sup>

This standard is issued under the fixed designation D5633; the number immediately following the designation indicates the year of original adoption or, in the case of revision, the year of last revision. A number in parentheses indicates the year of last reapproval. A superscript epsilon ( $\epsilon$ ) indicates an editorial change since the last revision or reapproval.

### 1. Scope

1.1 This practice covers the method and equipment used to collect surface and near-surface samples of soils and physically similar materials using a scoop.

1.2 *This standard does not purport to address all of the safety concerns, if any, associated with its use. It is the responsibility of the user of this standard to establish appropriate ~~safety~~ safety, health, and ~~health~~ environmental practices and determine the applicability of regulatory limitations prior to use.*

1.3 *This international standard was developed in accordance with internationally recognized principles on standardization established in the Decision on Principles for the Development of International Standards, Guides and Recommendations issued by the World Trade Organization Technical Barriers to Trade (TBT) Committee.*

### 2. Referenced Documents

#### 2.1 ASTM Standards:<sup>2</sup>

[D4687 Guide for General Planning of Waste Sampling](#)

[D5088 Practice for Decontamination of Field Equipment Used at Waste Sites](#)

[D5283 Practice for Generation of Environmental Data Related to Waste Management Activities: Quality Assurance and Quality Control Planning and Implementation](#)

[D5681 Terminology for Waste and Waste Management](#)

[D5792 Practice for Generation of Environmental Data Related to Waste Management Activities: Development of Data Quality Objectives](#)

[D6044 Guide for Representative Sampling for Management of Waste and Contaminated Media](#)

[D6232 Guide for Selection of Sampling Equipment for Waste and Contaminated Media Data Collection Activities](#)

#### 2.2 Other Documents:

~~Pierre Gy's~~ [Pierre Gy's Sampling Theory and Sampling Practice](#), Francis F. Pitard<sup>3</sup>

### 3. Terminology

3.1 *Definitions*—For definitions of terms used in this standard, see Terminology [D5681](#).

### 4. Summary of Practice

4.1 The top layers of material are removed down to the required sample depth using a shovel or other suitable equipment. A clean scoop is then used to collect the actual sample, which is placed in a sample container.

<sup>1</sup> This practice is under the jurisdiction of ASTM Committee [D34](#) on Waste Management and is the direct responsibility of Subcommittee [D34.01.03](#) on Sampling Equipment.

Current edition approved Sept. 1, 2016 May 1, 2021. Published September 2016 May 2021. Originally approved in 1994. Last previous edition approved in 2012 2016 as D5633 – 04 (2012) (2016). DOI: 10.1520/D5633-04R16.10.1520/D5633-21.

<sup>2</sup> For referenced ASTM standards, visit the ASTM website, [www.astm.org](http://www.astm.org), or contact ASTM Customer Service at [service@astm.org](mailto:service@astm.org). For *Annual Book of ASTM Standards* volume information, refer to the standard's Document Summary page on the ASTM website.

<sup>3</sup> Available from CRC Press, Inc., 2000 Corporate Blvd., NW, Boca Raton, FL 33431.

## 5. Significance and Use

5.1 This practice is intended for use in collecting samples of contaminated soils and similar materials.

5.2 Scoops are used primarily for collecting samples near the surface. Subsurface samples can be obtained by first removing higher layers using a shovel or other suitable equipment and collecting the sample with the scoop.

5.3 Because of their simplicity, scoops are useful in taking samples of waste materials where decontamination or disposal is a problem with other types of sampling equipment. Scoops are also suitable for use in rapid screening programs, pilot studies, and other semi-quantitative investigations.

5.4 Samples should be collected in accordance with an appropriate work plan (see Practice D5283 and Guide D4687).

## 6. Sampling Equipment

6.1 A shovel or other suitable equipment can be used for the initial removal of overburden material. This equipment should be manufactured from material that is compatible with the soil or waste to be sampled. The scoop must be manufactured from material that is compatible with the soil or waste to be sampled and the required test or analysis to be performed. For most hazardous waste sampling, either a disposable plastic scoop or a reusable stainless steel or polytetrafluoroethylene-coated scoop is suitable (see Guide D6232 and Practice D5792).

6.2 The design of the scoop is important to minimize sampling error, that is, all the material intended as the sample can be collected and placed in the sample container and is not lost as the scoop is systematically lifted from the source to the sample container (see Guide D6044, Pierre Gy's Sampling Theory and Sampling Practice, and Fig. 1).

6.3 For measurement of sample depth, a ruler or tape measure can be used.

6.4 The advantages of sampling with a scoop are that the scoops are:

6.4.1 ~~inexpensive~~, Inexpensive,

6.4.2 ~~easy~~ Easy to use, and

6.4.3 ~~easy~~ Easy to clean.

6.5 The limitations associated with sampling with a scoop are that the scoop may:

6.5.1 ~~affect~~ Affect the matrix during sample collection by selecting certain particle sizes,

6.5.2 ~~not~~ Not be constructed in a shape that is compatible with the dimensions of the matrix, and

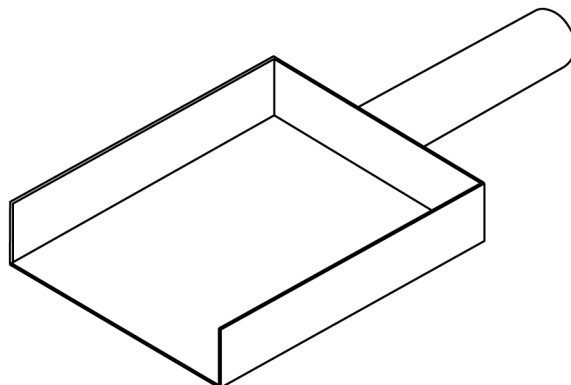

FIG. 1 Example of a Scoop