



Designation: ~~F1717–18~~ F1717 – 21

Standard Test Methods for Spinal Implant Constructs in a Vertebrectomy Model¹

This standard is issued under the fixed designation F1717; the number immediately following the designation indicates the year of original adoption or, in the case of revision, the year of last revision. A number in parentheses indicates the year of last reapproval. A superscript epsilon (ϵ) indicates an editorial change since the last revision or reapproval.

1. Scope

1.1 These test methods cover the materials and methods for the static and fatigue testing of spinal implant assemblies in a vertebrectomy model. The test materials for most combinations of spinal implant components can be specific, depending on the intended spinal location and intended method of application to the spine.

1.2 These test methods are intended to provide a basis for the mechanical comparison among past, present, and future spinal implant assemblies. They allow comparison of spinal implant constructs with different intended spinal locations and methods of application to the spine. These test methods are not intended to define levels of performance, since sufficient knowledge is not available to predict the consequences of the use of a particular device.

1.3 These test methods set out guidelines for load types and methods of applying loads. Methods for three static load types and one fatigue test are defined for the comparative evaluation of spinal implant assemblies.

1.4 These test methods establish guidelines for measuring displacements, determining the yield load, and evaluating the stiffness and strength of the spinal implant assembly.

1.5 Some spinal constructs may not be testable in all test configurations.

1.6 The values stated in SI units are to be regarded as standard. No other units of measurement are included in this standard.

1.7 *This standard does not purport to address all of the safety concerns, if any, associated with its use. It is the responsibility of the user of this standard to establish appropriate safety, health, and environmental practices and determine the applicability of regulatory limitations prior to use.*

1.8 *This international standard was developed in accordance with internationally recognized principles on standardization established in the Decision on Principles for the Development of International Standards, Guides and Recommendations issued by the World Trade Organization Technical Barriers to Trade (TBT) Committee.*

2. Referenced Documents

2.1 ASTM Standards:²

[D638 Test Method for Tensile Properties of Plastics](#)

[E4 Practices for Force Verification of Testing Machines](#)

¹ These test methods are under the jurisdiction of ASTM Committee F04 on Medical and Surgical Materials and Devices and are the direct responsibility of Subcommittee F04.25 on Spinal Devices.

Current edition approved June 1, 2018; April 1, 2021. Published August 2018; May 2021. Originally approved in 1996. Last previous edition approved in 2015 as F1717-18, 2015. DOI: 10.1520/F1717-18.10.1520/F1717-21.

² For referenced ASTM standards, visit the ASTM website, www.astm.org, or contact ASTM Customer Service at service@astm.org. For *Annual Book of ASTM Standards* volume information, refer to the standard's Document Summary page on the ASTM website.

- E6 Terminology Relating to Methods of Mechanical Testing
- E177 Practice for Use of the Terms Precision and Bias in ASTM Test Methods
- E691 Practice for Conducting an Interlaboratory Study to Determine the Precision of a Test Method
- E739 Practice for Statistical Analysis of Linear or Linearized Stress-Life ($S-N$) and Strain-Life ($\epsilon-N$) Fatigue Data
- E1150 Definitions of Terms Relating to Fatigue (Withdrawn 1996)³
- F543 Specification and Test Methods for Metallic Medical Bone Screws
- F1582 Terminology Relating to Spinal Implants
- F1798 Test Method for Evaluating the Static and Fatigue Properties of Interconnection Mechanisms and Subassemblies Used in Spinal Arthrodesis Implants
- F2077 Test Methods For Intervertebral Body Fusion Devices

3. Terminology

3.1 *Definitions:*

3.1.1 For definitions of terms relating to these test methods, see Terminology E6, Terminology F1582, and Definitions E1150.

3.2 *Definitions of Terms Specific to This Standard:*

3.2.1 *active length of the longitudinal element*—the straight line distance between the center of attachment of the superior anchor and the center of attachment of the inferior anchor.

3.2.2 *angular displacement at 2 % offset yield (degrees)*—the angular displacement of a construct measured via the actuator that produces a permanent angular displacement in the $X-Y$ plane equal to 0.020 times the torsional aspect ratio (see Point A in Fig. 1).

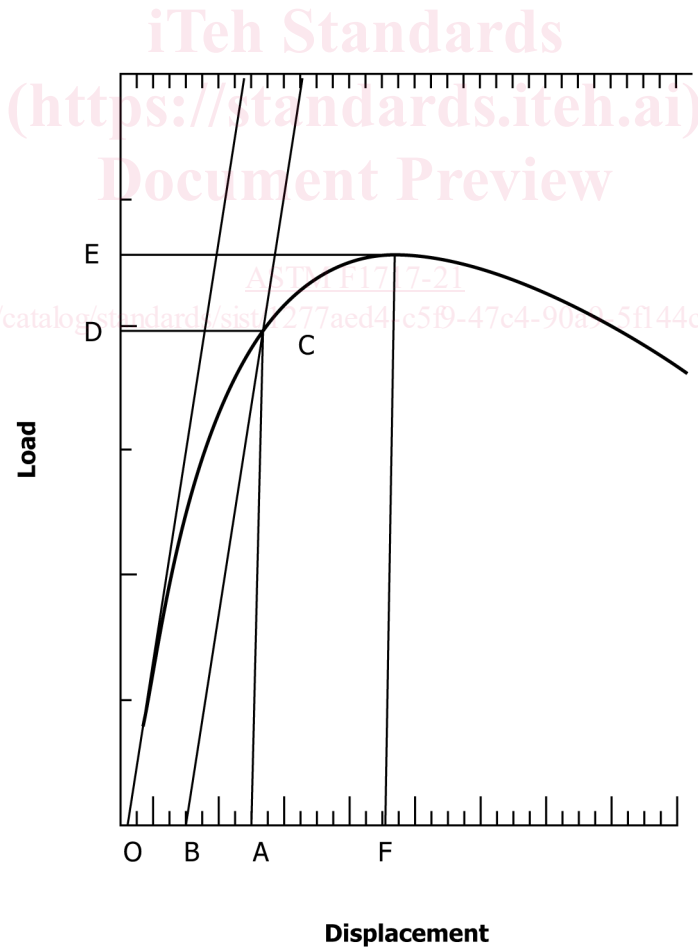

FIG. 1 Typical Load Displacement Curve or Torque Angulation Curve

³ The last approved version of this historical standard is referenced on www.astm.org.

3.2.3 *block moment arm*—the distance in the X direction in the X-Y plane between the axis of the hinge pin and either (1) the center of the insertion point of an anchor (screws and bolts), (2) the furthest point of contact between the block and plate (anterior plates), or (3) the center point of attachment on the roll pin farthest from the hinge pin (hooks and wires).

3.2.4 *compressive or tensile bending stiffness (N/mm)*—the compressive or tensile bending yield force divided by elastic displacement (see the initial slope of line BC in Fig. 1).

3.2.5 *compressive or tensile bending ultimate load (N)*—the maximum compressive or tensile force in the X-Z plane applied to a spinal implant assembly (see the force at Point E in Fig. 1). The ultimate load should be a function of the device and not of the load cell or testing machine.

3.2.6 *compressive or tensile bending yield load (N)*—the compressive or tensile bending force in the X-Z plane necessary to produce a permanent deformation equal to 0.020 times the active length of the longitudinal element (see the force at Point D in Fig. 1).

3.2.7 *coordinate system/axes*—three orthogonal axes are defined in Fig. 2 and Fig. 3. The anterior-posterior axis is X with positive being anterior. The medial-lateral axis is Y with left being positive when viewed posteriorly. The superior-inferior axis is Z with superior being positive.

3.2.8 *displacement at 2 % offset yield (mm)*—the displacement of a construct measured via the actuator that produces a permanent deformation equal to 0.020 times the active length of the longitudinal element (see Point A in Fig. 1).

3.2.9 *elastic angular displacement (degrees)*—the angular displacement at 2 % offset yield (see Point A in Fig. 1) minus the 2 % offset angular displacement (see Point B in Fig. 1). (The distance between Point A and Point B in Fig. 1.)

3.2.10 *elastic displacement (mm)*—the displacement at 2 % offset yield (see Point A in Fig. 1) minus the 2 % offset displacement (see Point B in Fig. 1). (The distance between Point A and Point B in Fig. 1.)

3.2.11 *failure*—permanent deformation resulting from fracture, plastic deformation, or loosening beyond the ultimate displacement or loosening that renders the spinal implant assembly ineffective or unable to adequately resist load.

3.2.12 *fatigue life*—the number of loading cycles, N , of a specified character that the spinal implant assembly sustains before failure of a specified nature occurs (see Definitions E1150).

3.2.13 *insertion point of an anchor*—the location where the anchor is attached to the test block. The insertion points shown in Figs. 2-15 are to be adhered to if possible. In situations where the design of the spinal implant assembly or the manufacturer's surgical instructions for installation dictate otherwise, the attachment points may deviate from these dimensions.

3.2.14 *intended method of application*—spinal implant assemblies contain different types of anchors. Each type of anchor has an intended method of application to the spine.

3.2.15 *intended spinal location*—the anatomic region of the spine intended for the application of the spinal implant assembly. Spinal implant assemblies are developed for specific spinal locations such as the anterior cervical spine or the posterior thoracolumbar, lumbar, and lumbosacral spine.

3.2.16 *hinge pin*—the cylindrical rod connecting a test block to a side support. A cervical construct is secured with a 9.6 mm diameter pin and the thoracolumbar, lumbar, and lumbosacral construct uses a 12.7 mm diameter pin.

3.2.17 *longitudinal direction*—the initial spatial orientation parallel to the longitudinal element of the spinal implant assembly. The longitudinal direction is generally in the superior-inferior direction and, therefore, generally parallel to the z axis.

3.2.18 *maximum run-out load*—the maximum load that can be applied to a spinal implant assembly where all of the tested constructs have withstood 5 000 000 cycles without a failure.

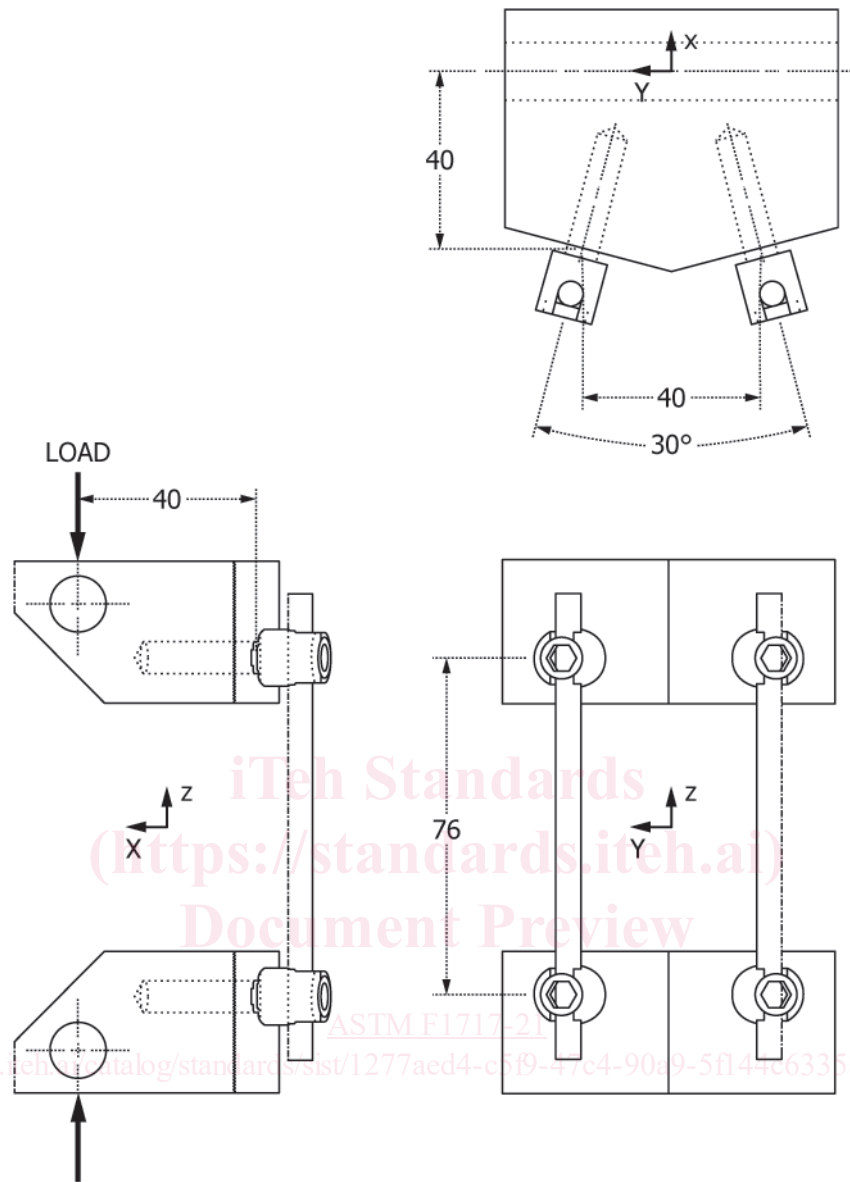

FIG. 2 Typical Bilateral Construct Containing Bone Screws, Rods, and Set Screws

3.2.19 *permanent deformation*—the displacement (mm) or angular displacement (degree) of the spinal implant construct relative to the initial unloaded condition as measured via the actuator after the applied load, moment, or torque has been removed.

3.2.20 *spinal implant assembly*—a complete spinal implant configuration as intended for surgical use. A spinal implant assembly will contain anchors, interconnections, and longitudinal elements and may contain transverse elements (see Fig. 4, Fig. 6, Fig. 8, Fig. 10, Fig. 12, and Fig. 14).

3.2.21 *spinal implant construct*—a complete spinal implant assembly attached to the appropriate test blocks.

3.2.22 *test block*—the component of the test apparatus for mounting the spinal implant assembly. A specific design of test block is required for each intended spinal location and intended method of application. Fig. 5, Fig. 7, Fig. 9, Fig. 11, Fig. 13, and Fig. 15 describe the recommended designs for the test blocks; however, alternate designs can be used as long as equivalent performance is demonstrated.

3.2.23 *test block load point*—the location on the test block at which the resultant load is transmitted from the test apparatus.

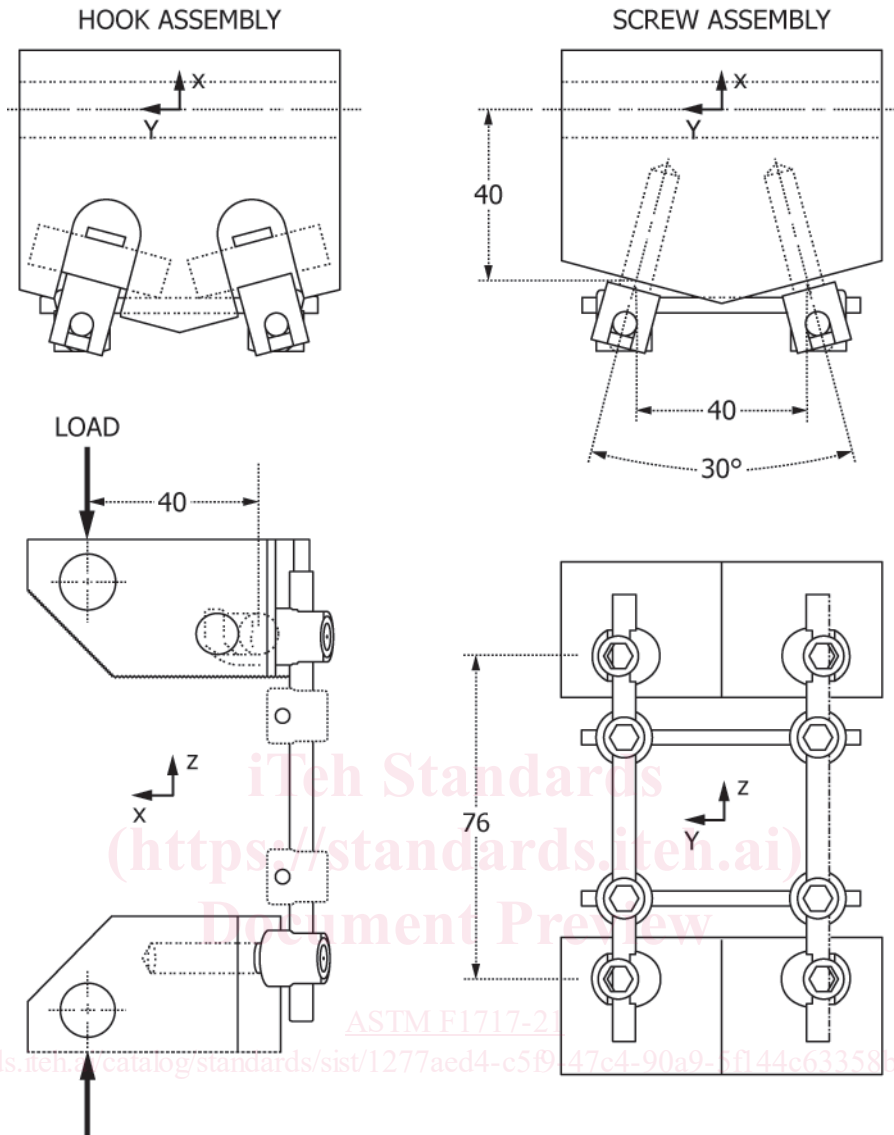

FIG. 3 A Bilateral Hook, Rod, Screw, and Transverse Element Construct

3.2.24 *tightening torque*—the specified torque that is applied to the various threaded fasteners of the spinal implant assembly.

3.2.25 *torsional aspect ratio*—the active length of the longitudinal element divided by the distance from the center of rotation to the insertion point of an anchor (for example: in Fig. 24 1.701.14 for a 76-mm 35-mm active length, $X=40=30$ mm and $Y=40=S/2$ mm), where $S = 12$ mm).

$$A = \frac{L}{D} = \frac{L}{(x^2 + y^2)^{1/2}} \quad (1)$$

where:

- A = torsional aspect ratio,
- L = active length of longitudinal element,
- D = distance to insertion point,
- x = x distance to insertion point, and
- y = y distance to insertion point.

3.2.26 *torsional stiffness (N-m/degree)*—the yield torque (N-m) divided by elastic angular displacement (degrees) (the initial slope of line BC in Fig. 1).

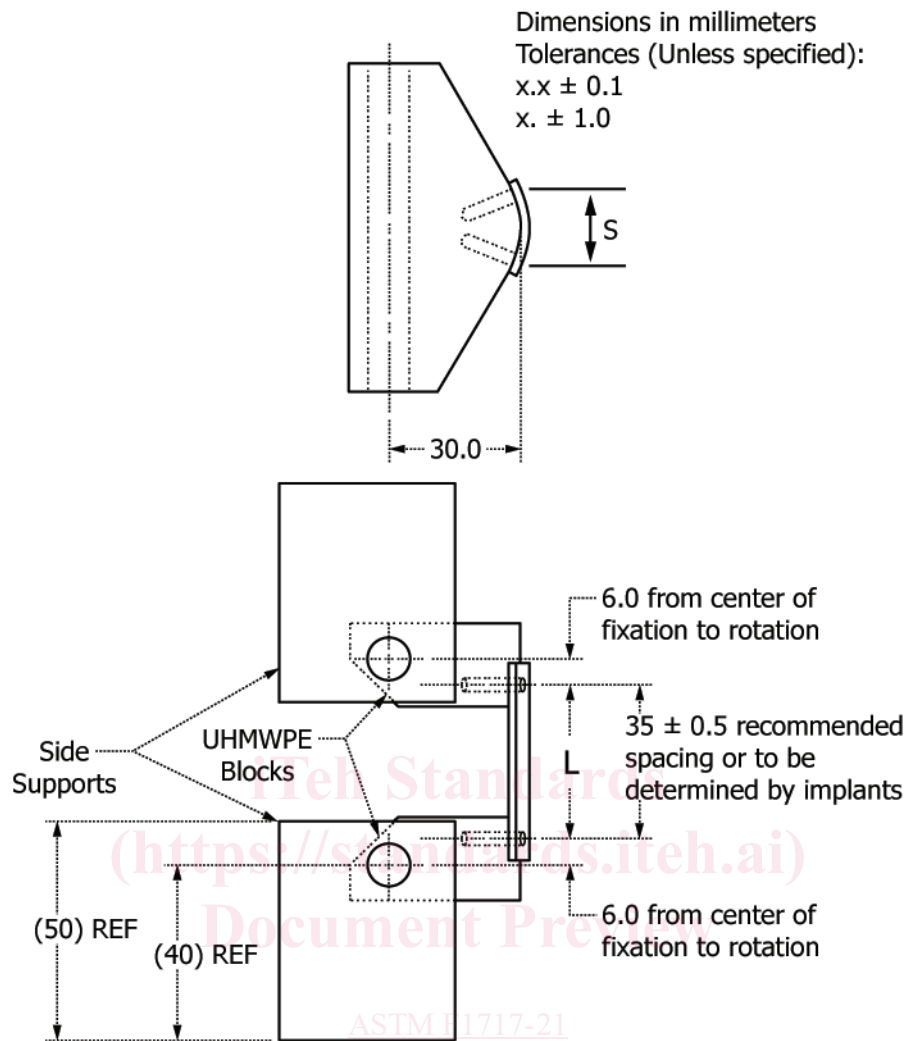

FIG. 4 Cervical Unilateral Construct for Plates

3.2.27 *torsional ultimate load (N-m)*—the maximum torque in the X-Y plane applied to a spinal implant assembly (the torque at Point E in Fig. 1). The ultimate torque should be a function of the device and not of the load cell or testing machine.

3.2.28 *two percent (2 %) offset angular displacement (degrees)*—a permanent angular displacement in the X-Y plane measured via the actuator equal to 0.020 times the torsional aspect ratio (for example: 1.95° for $1.70 \times 0.02 \times 180^\circ/\pi$) (see Point B in Fig. 1).

3.2.29 *two percent (2 %) offset displacement (mm)*—a permanent deformation measured via the actuator equal to 0.020 times the active length of the longitudinal element (for example: 1.52 mm for a 76 mm active length of the longitudinal element or 0.70 mm for 35 mm) (see Point B in Fig. 1).

3.2.30 *ultimate displacement (mm)*—the displacement associated with the ultimate load, ultimate bending load, or ultimate torque (the displacement at Point F in Fig. 1).

3.2.31 *yield torque (N-m)*—the torque in the X-Y plane required to produce a permanent displacement of 0.020 times the torsional aspect ratio (the torque at Point D in Fig. 1).

3.2.32 *zero displacement intercept (mm)*—the intersection of the straight line section of the load displacement curve and the zero load axis (the zero displacement reference Point 0 in Fig. 1).

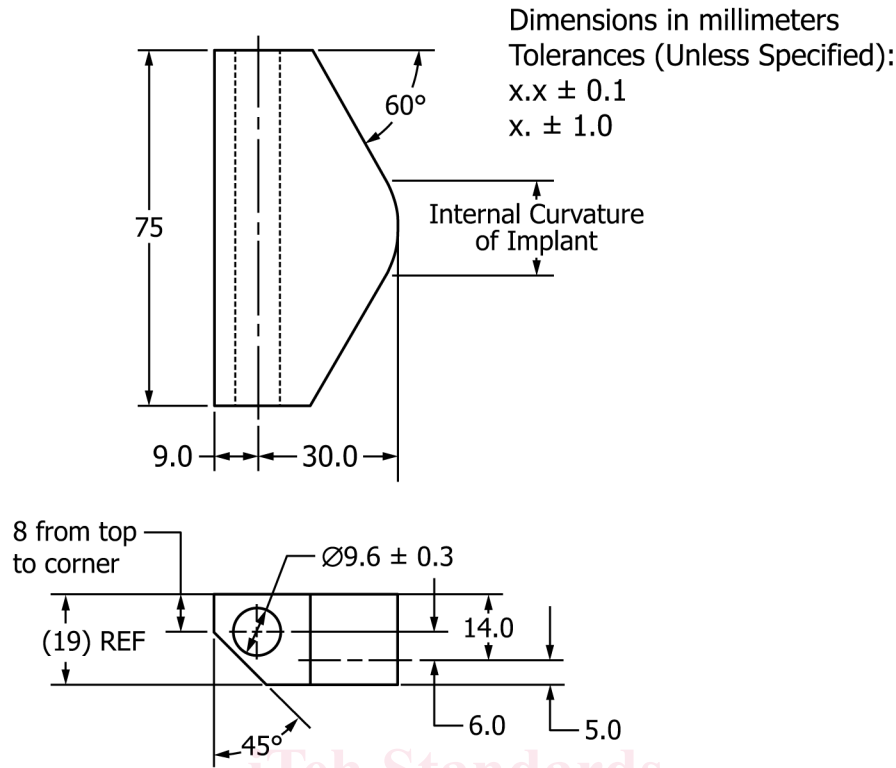

FIG. 5 Cervical Unilateral UHMWPE Block for Plates

4. Summary of Test Methods

4.1 Similar test methods are proposed for the mechanical evaluation of cervical spinal implant assemblies (see Fig. 4, Fig. 6, and Fig. 8) and thoracolumbar, lumbar, and lumbosacral spinal implant assemblies (see Fig. 10, Fig. 12, and Fig. 14).

4.2 Testing of the spinal implant assemblies will simulate a vertebrectomy model via a large gap between two Ultra High Molecular Weight Polyethylene (UHMWPE) test blocks. The UHMWPE used to manufacture the test blocks should have a tensile breaking strength equal to 40 ± 3 MPa (see Specification-Test Method D638). The UHMWPE test blocks (see Fig. 5, Fig. 7, Fig. 9, Fig. 11, Fig. 13, and Fig. 15) will eliminate the effects of the variability of bone properties and morphometry. Alternate designs of test blocks may be used as long as equivalent performance is demonstrated.

4.3 Three static mechanical tests and one dynamic test will evaluate the spinal implant assemblies. The three static mechanical tests are compression bending, tensile bending, and torsion. The dynamic test is a compression bending fatigue test. It is the responsibility of the user of this standard to determine which test(s) is (are) most appropriate for a particular spinal implant assembly.

4.3.1 Assessment of cervical, thoracolumbar, lumbar, and lumbosacral spinal implant assemblies in torsion is not required for those assemblies consisting of hooks, cables, wires, or rods in combination with vertebral body, pedicle, or sacral screws.

4.4 A specific clinical indication generally requires a specific spinal implant assembly. Spinal implant assemblies will be evaluated with test configurations which simulate the clinical requirements for the intended spinal location. The intended spinal locations are both anterior (see Fig. 4) and posterior (see Fig. 6 and Fig. 8) surfaces of the cervical spine or both anterior (see Fig. 10) and posterior (see Fig. 12 and Fig. 14) surfaces of the thoracolumbar, lumbar, and lumbosacral spine. The block moment arm (see 6.6) for a test configuration depends on the intended spinal location. The cervical spine configuration (see Fig. 5, Fig. 7, and Fig. 9) specifies one block moment arm, while a larger block moment arm (see Fig. 11, Fig. 13, and Fig. 15) is specified for the thoracolumbar, lumbar, and lumbosacral spine.

4.5 The intended method of application of the spinal implant assembly may vary for specific anatomic regions and clinical indications. Spinal implant assemblies contain different types of anchors. Each type of anchor has an intended method of

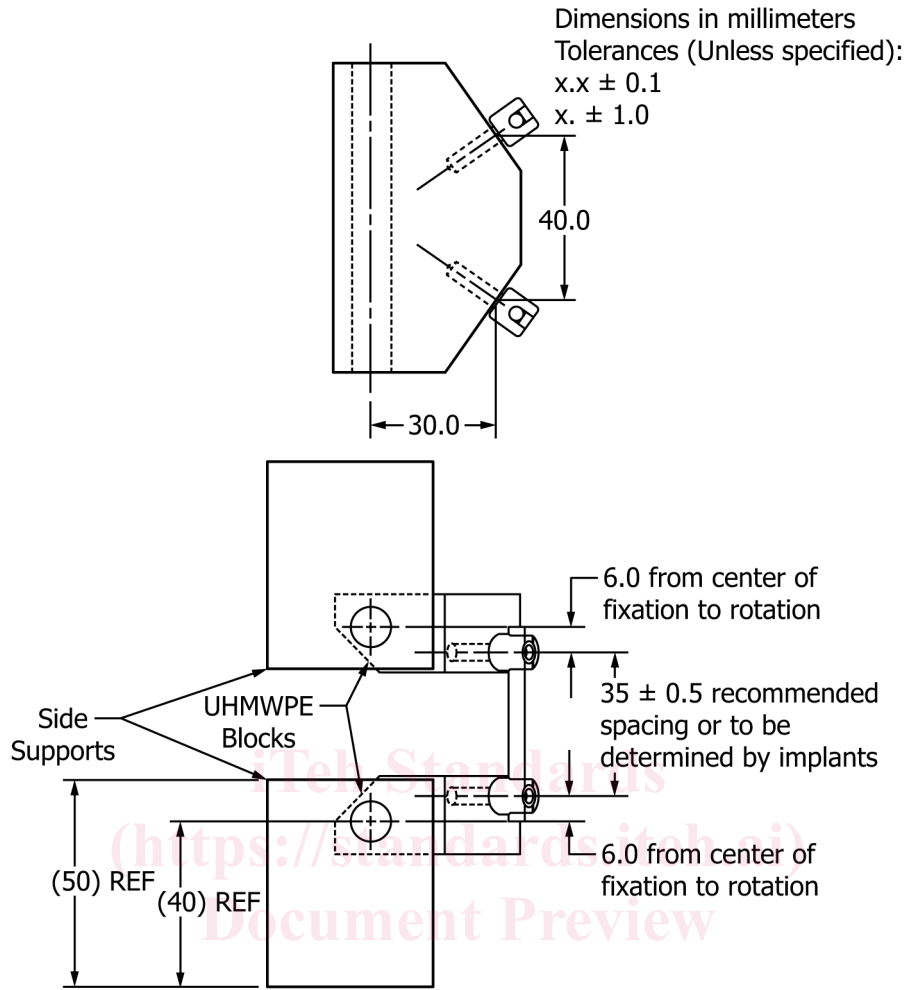

FIG. 6 Cervical Bilateral Construct Test Setup for Screws or Bolts

<https://standards.iteh.ai/catalog/standards/sist/1277aed4-c519-47c4-90a9-5f144c63358b/astm-f1717-21>

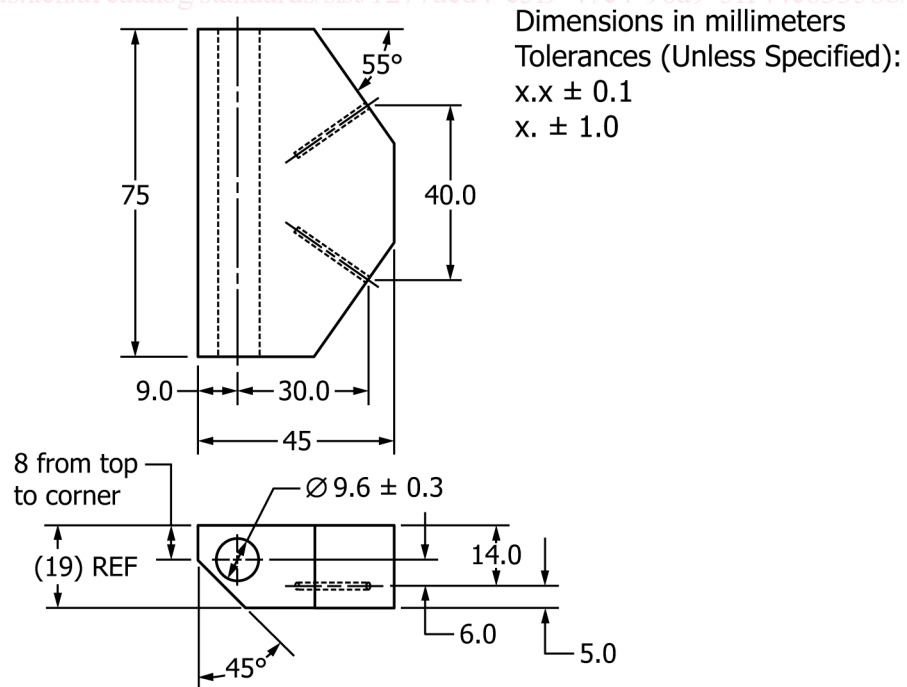

FIG. 7 Cervical Bilateral UHMWPE Block for Screws or Bolts

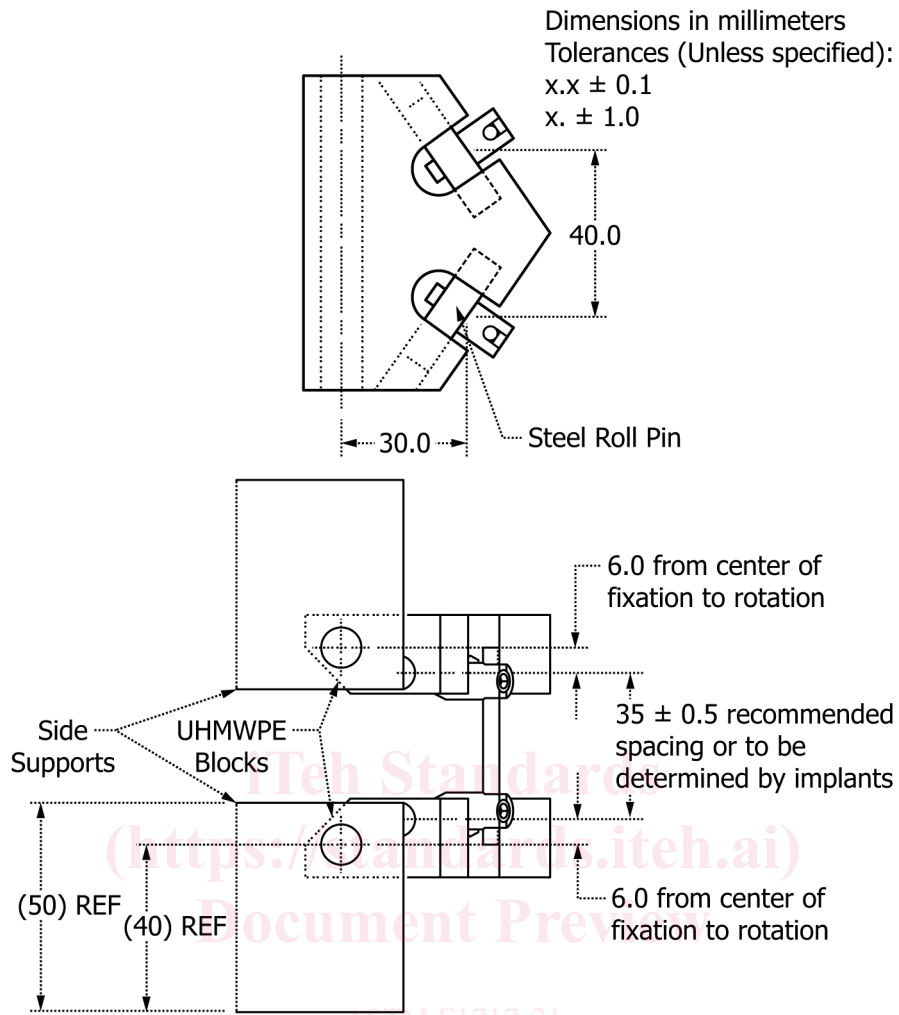

FIG. 8 Cervical Bilateral Construct Test Setup for Hooks, Cables, or Wires

<https://standards.iteh.ai/catalog/standards/sist/1277aed4-c519-47c4-90a9-51144c63358b/astm-f1717-21>

application to the spine. For example, one assembly may include anterior vertebral body screws and rods (see Fig. 2), while another assembly may contain posterior sacral screws, hooks, rods, and transverse elements (see Fig. 3). The block moment arm of a test configuration will be independent of the intended method of application of a spinal implant assembly; therefore, the test data for different intended methods of application may be compared.

5. Significance and Use

5.1 Spinal implants are generally composed of several components which, when connected together, form a spinal implant assembly. Spinal implant assemblies are designed to provide some stability to the spine while arthrodesis takes place. These test methods outline standard materials and methods for the evaluation of different spinal implant assemblies so that comparison between different designs may be facilitated.

5.2 These test methods are used to quantify the static and dynamic mechanical characteristics of different designs of spinal implant assemblies. The mechanical tests are conducted *in vitro* using simplified load schemes and do not attempt to mimic the complex loads of the spine.

5.3 The loads applied to the spinal implant assemblies *in vivo* will, in general, differ from the loading configurations used in these test methods. The results obtained here cannot be used directly to predict *in vivo* performance. The results can be used to compare different component designs in terms of the relative mechanical parameters.

5.4 Fatigue testing in a simulated body fluid or saline may cause fretting, corrosion, or lubricate the interconnections and thereby affect the relative performance of tested devices. This test should be initially performed dry (ambient room conditions) for

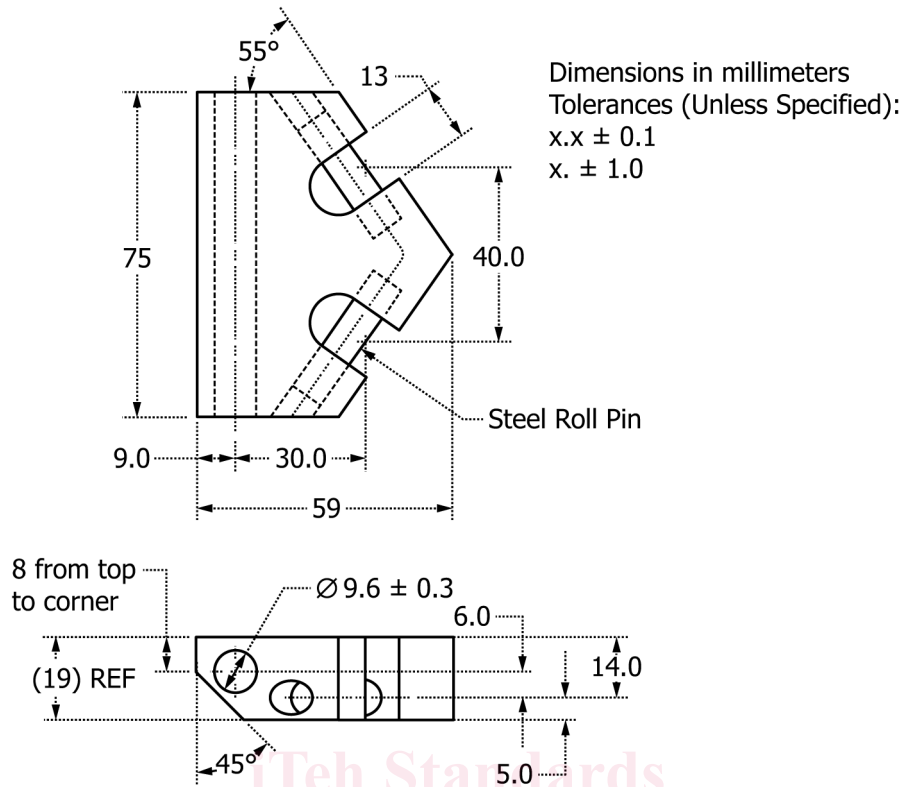

FIG. 9 Cervical Bilateral UHMWPE Block for Hooks, Cables, or Wires

consistency. The effect of environment may be significant. Repeating all or part of these test methods in simulated body fluid, saline (9 g NaCl per 1000 mL water), a saline drip, water, or a lubricant should be considered. The maximum recommended frequency for this type of cyclic testing should be 5 Hz.

5.5 The location of the longitudinal elements is determined by where the anchors are clinically placed against bony structures. The perpendicular distance to the load direction (block moment arm) between the axis of a hinge pin and the anchor's attachment points to a UHMWPE block is independent of anchor type. The distance between the anchor's attachment point to the UHMWPE block and the center of the longitudinal element is a function of the interface design between the screw, hook, wire, cable, and so forth, and the rod, plate, and so forth.

5.6 During static torsion testing, the rotation direction (clockwise or counter clockwise) may have an impact on the results.

6. Apparatus

6.1 Test machines will conform to the requirements of Practices E4.

6.2 The test apparatus allows multiple loading regimes to be applied to all forms of spinal implant assemblies. Two pairs of side supports are mounted on the test machine (see Fig. 4, Fig. 6, Fig. 8, Fig. 10, Fig. 12, and Fig. 14). One pair of side supports attach to the actuator and the second to the load cell. A mounting plate for one of the sets of side support plates should be free to rotate about the Z axis for the compression bending, tension bending, and fatigue tests. UHMWPE blocks are connected to the side supports via hinge pins. All testing will simulate a vertebrectomy model via a large gap between the two UHMWPE blocks. Select the appropriate design of the UHMWPE blocks (see Fig. 5, Fig. 7, Fig. 9, Fig. 11, Fig. 13, and Fig. 15) to facilitate testing of the spinal implant assembly in a manner that simulates the specific clinical indication at the intended spinal location.

6.3 The design of the UHMWPE blocks causes the plane through the spinal implant assemblies to be parallel to the plane (the Y-Z plane) through the axes of the hinge pins. Align the superior side supports and UHMWPE block with the inferior side supports and UHMWPE block. The center axis of each hinge pin should be perpendicular ($\pm 0.5^\circ$) to and aligned (± 0.5 mm) with the load axis of the test machine. Center the test apparatus in the test machine such that the line through the mid-point (0, 0, Z1) of the

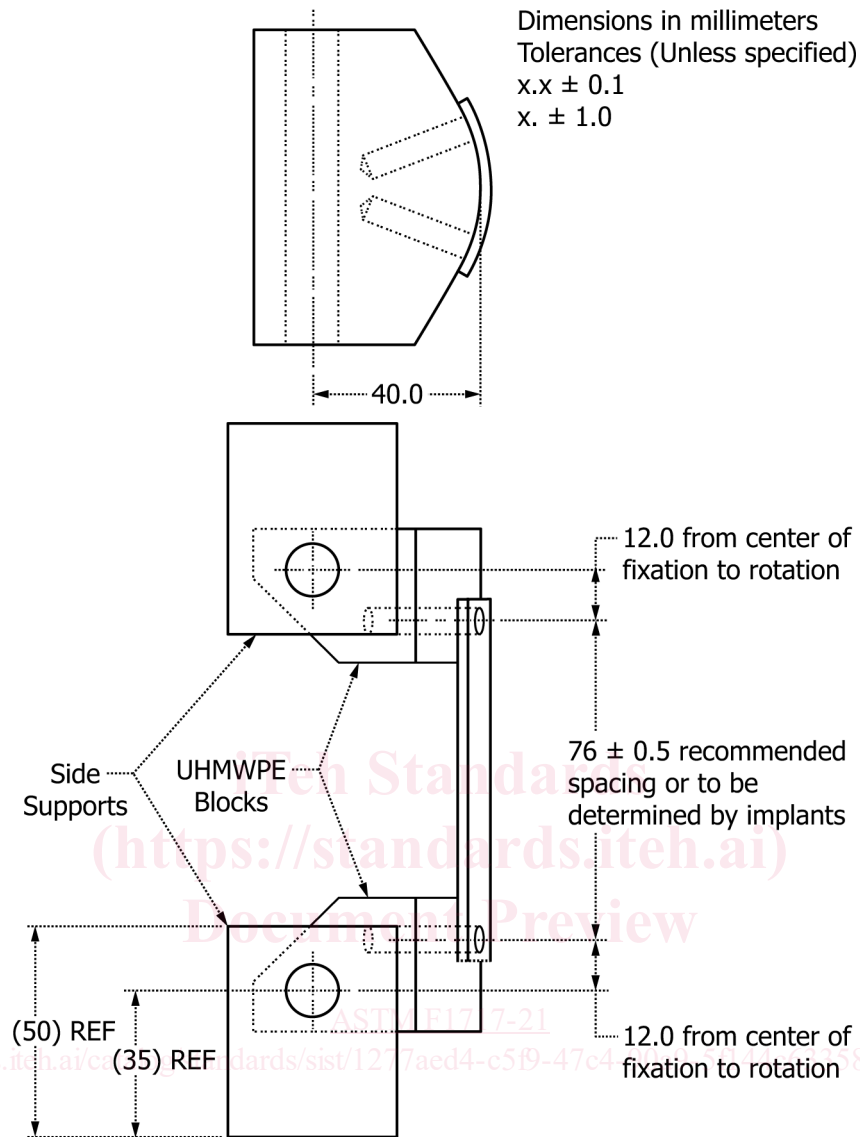

FIG. 10 Lumbar Unilateral Construct for Plates

inferior hinge pin's axis and the mid-point (0, 0, Z2) of the superior hinge pin's axis is collinear within ± 0.1 mm of the load and rotational axis of the test machine's actuator.

6.4 Alternate designs of test blocks may be used as long as equivalence is demonstrated. The solid UHMWPE test blocks may be replaced with metal blocks with UHMWPE inserts of appropriate size. Any surface or component of the spinal assembly which would contact the solid UHMWPE should also contact an appropriate thickness of the UHMWPE. If screws are used to mount the spinal construct to the test blocks (see Fig. 5, Fig. 7, Fig. 11, and Fig. 13), then the screws must be placed into UHMWPE inserts in the alternate design of test block. The diameter of the UHMWPE inserts must be equal to or greater than three times the diameter of the screws.

6.5 If the locations of the superior anchors, inferior anchors, or both sets of anchors are dictated by the longitudinal element and are at different Z locations (a diagonal), then the set of anchors should be centered above and below the standard location such that they maintain the average Z location. If the anchors are secured into slots in the longitudinal element, then they should be centrally placed in the slots and not at either end to produce a worst-case scenario.

6.6 The distance in the X direction between the axis of a hinge pin and the anchors' attachment point should remain constant when comparing spinal implant assemblies. Spinal implant assemblies are designed for two intended spinal locations having two unique block moment arms. The two intended spinal locations are the cervical spinal implant system (see Fig. 4, Fig. 6, and Fig. 8) and