



Designation: **C348 – 20** C348 – 21

Standard Test Method for Flexural Strength of Hydraulic-Cement Mortars¹

This standard is issued under the fixed designation C348; the number immediately following the designation indicates the year of original adoption or, in the case of revision, the year of last revision. A number in parentheses indicates the year of last reapproval. A superscript epsilon (ϵ) indicates an editorial change since the last revision or reapproval.

1. Scope*

1.1 This test method covers the determination of the flexural strength of hydraulic-cement mortars.

1.2 The values stated in SI units are to be regarded as standard. No other units of measurement are included in this standard.

1.3 Values in SI units shall be obtained by measurement in SI units or by appropriate conversion, using the Rules for Conversion and rounding given in **IEEE/ASTM SI 10**, of measurements made in other units.

1.4 *This standard does not purport to address all of the safety concerns, if any, associated with its use. It is the responsibility of the user of this standard to establish appropriate safety, health, and environmental practices and determine the applicability of regulatory limitations prior to use. (Warning—Fresh hydraulic cementitious mixtures are caustic and may cause chemical burns to skin and tissue upon prolonged exposure.²)*

1.5 *This international standard was developed in accordance with internationally recognized principles on standardization established in the Decision on Principles for the Development of International Standards, Guides and Recommendations issued by the World Trade Organization Technical Barriers to Trade (TBT) Committee.*

2. Referenced Documents

- 2.1 *ASTM Standards:*³
- [C109/C109M Test Method for Compressive Strength of Hydraulic Cement Mortars \(Using 2-in. or \[50 mm\] Cube Specimens\)](#)
 - [C125 Terminology Relating to Concrete and Concrete Aggregates](#)
 - [C219 Terminology Relating to Hydraulic and Other Inorganic Cements](#)
 - [C230/C230M Specification for Flow Table for Use in Tests of Hydraulic Cement](#)
 - [C305 Practice for Mechanical Mixing of Hydraulic Cement Pastes and Mortars of Plastic Consistency](#)
 - [C349 Test Method for Compressive Strength of Hydraulic-Cement Mortars \(Using Portions of Prisms Broken in Flexure\)](#)
 - [C670 Practice for Preparing Precision and Bias Statements for Test Methods for Construction Materials](#)
 - [C778 Specification for Standard Sand](#)
 - [C1005 Specification for Reference Masses and Devices for Determining Mass and Volume for Use in Physical Testing of Hydraulic Cements](#)
 - [C1437 Test Method for Flow of Hydraulic Cement Mortar](#)
 - [IEEE/ASTM SI 10 Standard for Use of the International System of Units \(SI\): The Modern Metric System](#)

3. Terminology

3.1 Definitions:

¹ This test method is under the jurisdiction of ASTM Committee C01 on Cement and is the direct responsibility of Subcommittee C01.27 on Strength. Current edition approved April 1, 2020/April 1, 2021. Published April 2020/May 2021. Originally approved in 1954. Last previous edition approved in 2019/2020 as C348 – 19: C348 – 20. DOI: 10.1520/C0348-20.10.1520/C0348-21.

² See the section on Safety, Manual of Cement Testing, *Annual Book of ASTM Standards*, Vol 04.01.

³ For referenced ASTM standards, visit the ASTM website, www.astm.org, or contact ASTM Customer Service at service@astm.org. For *Annual Book of ASTM Standards* volume information, refer to the standard's Document Summary page on the ASTM website.

*A Summary of Changes section appears at the end of this standard

3.1.1 For definitions of terms used in this test method, refer to Terminology **C125** and **C219**.

4. Summary of Test Method

4.1 The test mortar used consists of one part cement and 2.75 parts of sand proportion by mass. Portland or air-entraining portland cements are mixed at specified water-cement ratios. Water content of other cements is that sufficient to obtain a flow of $110 \pm 5\%$ with 25 drops of the flow table. Test prisms, 40 by 40 by 160 mm, are molded by tamping in two layers. Prisms are cured one day in the molds and stripped until tested by center point loading.

5. Significance and Use

5.1 This test method provides a means for determining the flexural strength of hydraulic cement mortars. Portions of the mortar prisms tested in flexure in accordance with this test method may be used for the determination of compressive strength in accordance with Test Method **C349**.

5.2 The values are determined from this test method for research or reference purposes only and are not used for determining compliance with specification requirements.

6. Apparatus

6.1 *Weights, Weighing Devices, and Glass Graduates*—Weights, weighing devices, and glass graduates shall conform to the requirements of Specification **C1005**. The balance shall be evaluated for precision and accuracy at 2000 g.

6.2 *Mixer, Bowl, and Paddle*—An electrically driven mechanical mixer of the type equipped with paddle and mixing bowl, as specified in the Apparatus section of Practice **C305**.

6.3 *Flow Table and Flow Mold*—Flow table and flow mold shall conform to Specification **C230/C230M**.

6.4 *Specimen Molds*—Molds for the 40 by 40 by 160 mm prism specimens shall be triple-gang molds and shall be so designed that the specimens will be molded with their longitudinal axes in a horizontal position. The molds shall be made of a hard metal, not attacked by cement mortar, and with a Rockwell hardness of not less than HRB 55. The parts of the molds shall be matchmarked and, when assembled, shall be tight-fitting and positively held together. The sides of the molds shall be sufficiently rigid to prevent spreading or warping. The interior faces of the molds shall be plane surfaces with a permissible variation, in any 50 mm line on a surface, of 0.03 mm for new molds and 0.05 mm for molds in use. The distance between opposite sides shall be 40 ± 0.13 mm for new molds and 40 ± 0.3 mm for molds in use. The height of the molds shall be 40 mm with permissible variations of +0.25 and -0.15 mm for new molds, and +0.25 and -0.40 mm for molds in use. The inside length of the molds shall be 160 ± 2.5 mm. The angle between adjacent interior faces and top and bottom planes of the mold shall be $90 \pm 0.5^\circ$, measured at points slightly removed from the intersections of the faces. The base plate shall be approximately 10 mm in thickness and shall have a plane surface 200 by 180 mm with a permissible variation in any 50 mm line on the surface of 0.03 mm.

6.5 *Tamper*—The tamper (see **Fig. 1**) shall be made of nonabsorptive, nonabrasive material, such as a rubber compound having a Shore A durometer hardness of 80 ± 10 , or seasoned oak wood rendered nonabsorptive by immersion for 15 min in paraffin at approximately 200 °C. The face of the tamper shall be 22 by 85 mm.

6.6 *Tamper Guide*—The tamper guide (see **Fig. 2**) shall be made of metal (such as brass of Rockwell hardness not less than HRB 55) not attacked by the cement mortar. It shall lie flat on the mold and shall not protrude over any interior edge of the form more than 0.40 mm. The height of the guide shall be 25 mm.

6.7 *Trowel*—The trowel shall have a steel blade 115 by 250 mm in length, with straight edges.

6.8 *Flexure Testing Device*—The centerpoint loading method shall be used in making flexure tests on the prism specimens. The device used shall be designed such that the forces applied to the specimen will be vertical only and applied without eccentricity. A device that accomplishes this purpose, for use in a compression testing machine, is shown in **Fig. 3**. Apparatus for making flexure tests of mortar specimens shall be designed to incorporate the following principles:

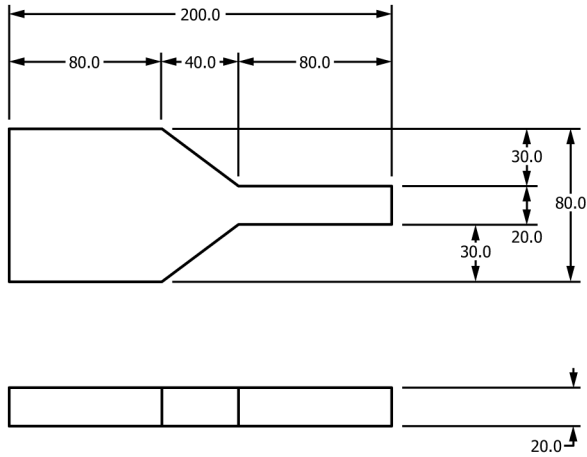

NOTE:

1. ALL DIMENSIONS IN MILLIMETERS

DETAIL / TAMPER
Scale: None

FIG. 1 Tamper

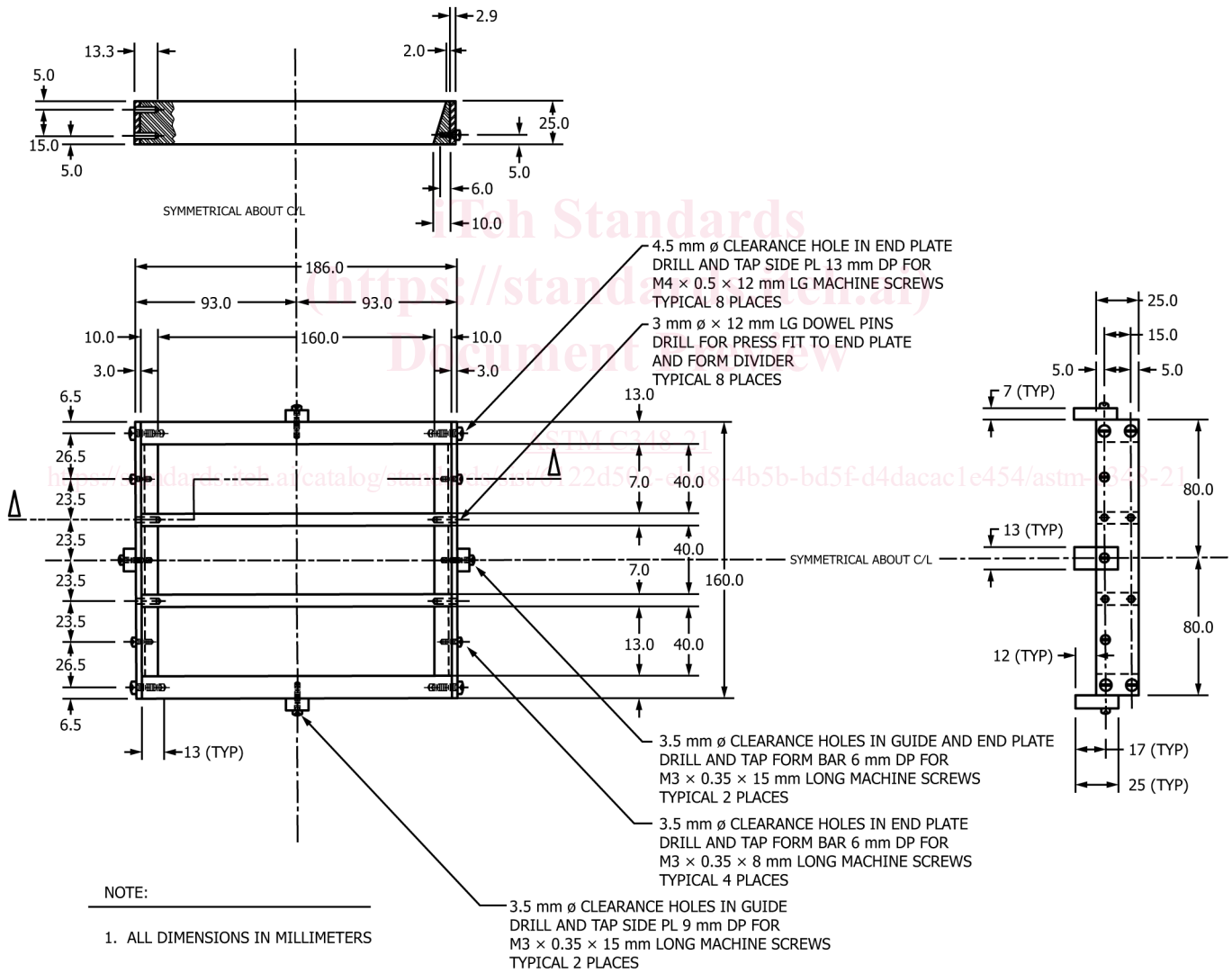

DETAIL / TAMPER GUIDE ATTACHMENT
Scale: None

FIG. 2 Tamper Guide Attachment

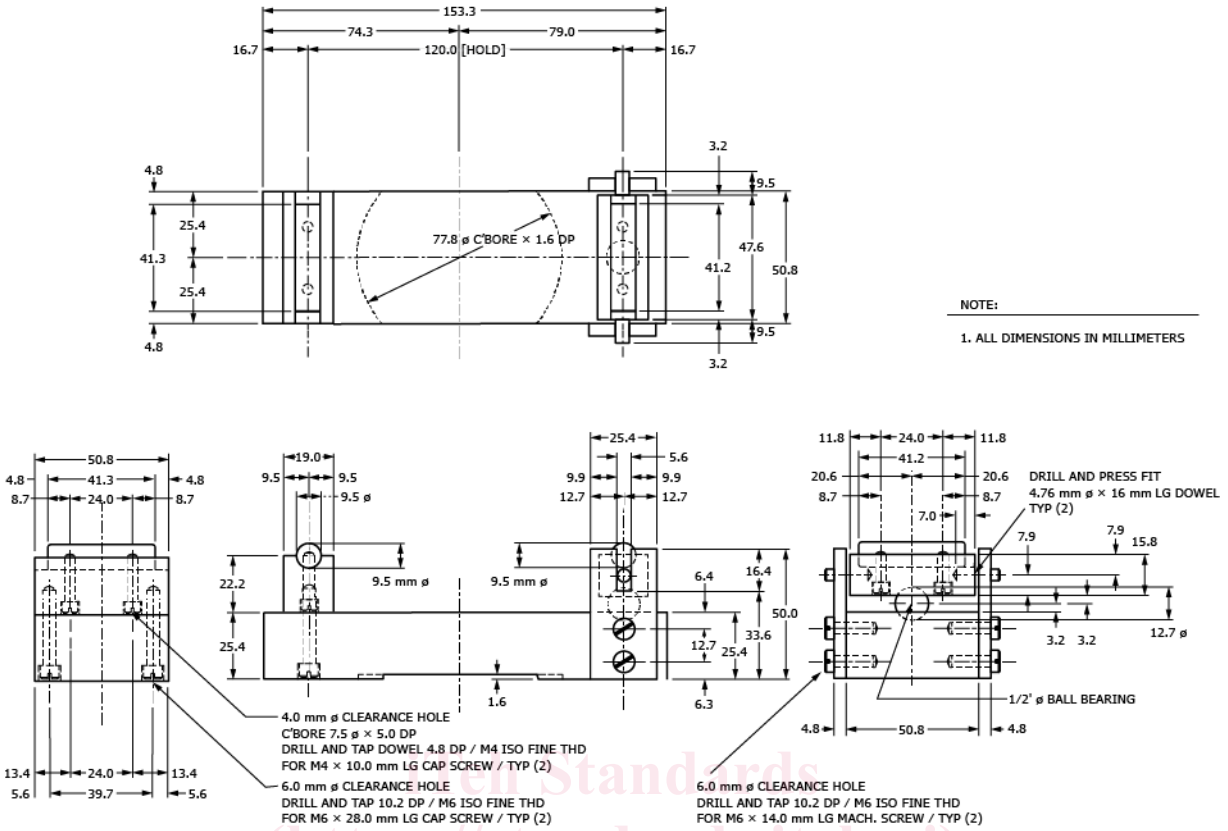

DETAIL / BASE PLATE AND SUPPORT EDGES
Scale: None

(a) Base Plate and Support Edges.

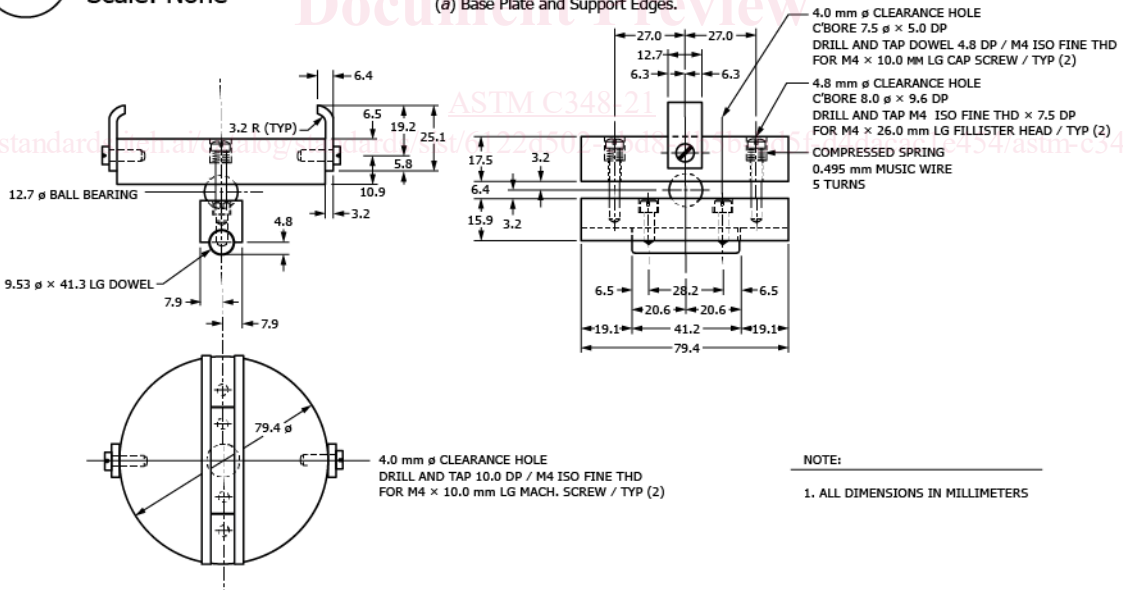

DETAIL / CENTER-POINT LOADING COMPONENT
Scale: None

(b) Center-Point Loading Component.

FIG. 3 Special Components for Adapting Compression Testing Machine for Testing 40 by 40 by 160 mm Prisms

6.8.1 The distance between supports and points of load application shall remain constant.

6.8.2 The load shall be applied normal to the loaded surface of the specimen and in such a manner as to avoid all eccentricity of loading.

6.8.3 The direction of the reactions should be parallel to the direction of the applied load at all times during the test.

6.8.4 The load should be applied at a uniform rate and in a manner to avoid shock.

6.9 *Compression Testing Machine*—The compression testing machine used with the flexure testing device, as shown in Fig. 3, shall be of the hydraulic type and conform to the requirements prescribed in Test Method C109/C109M.

NOTE 1—Most hydraulic compression machines designed for breaking 50 mm cubes have a relatively small diameter lower bearing surface directly centered below the upper spherically seated head, on which close-fitting pedestals of appropriate heights are set for breaking 50 mm cubes and 50 by 100 mm or 75 by 150 mm cylinders. The base plate of the flexure testing apparatus shown in Fig. 3 is designed to rest on the low pedestal intended for tests on 75 by 150 mm.

NOTE 2—In the absence of self-centering arrangements on machines with large lower bearing surfaces, the center of this surface directly below the center of the upper spherically seated head shall be accurately located. A circle or concentric circles of appropriate diameters shall be scribed on the lower bearing surface around this point. A cylindrical pedestal of appropriate diameter and height shall be obtained. End faces of the pedestal must be plane and parallel and at 90° to the axis of the cylinder. The upper face shall have a diameter of 77.5 mm.

7. Materials

7.1 *Graded Standard Sand:*

7.1.1 The sand used for making test specimens shall be natural silica sand and conform to Specification C778.

8. Number of Specimens

8.1 Three or more specimens shall be made for each period of test specified.

9. Preparing Specimen Molds

9.1 Prepare the specimen molds as prescribed in Test Method C109/C109M.

10. Procedure

10.1 *Proportioning, Consistency, and Mixing of Mortars*—The proportioning, consistency, and mixing of the standard mortar shall be in accordance with the Procedure section of Test Method C109/C109M.

10.2 *Determination of Flow*—The flow shall be determined in accordance with Test Method C1437.

10.3 *Molding Test Specimens:*

10.3.1 Immediately following completion of the flow test, return the mortar from the flow table to the mixing bowl. Quickly scrape down into the batch the mortar that may have collected on the side of the bowl and then remix the entire batch 15 s at medium speed. Upon completion of mixing, the mixing paddle shall be shaken to remove excess mortar into the mixing bowl.

10.3.2 When a duplicate batch is to be made immediately for additional specimens, the flow test may be omitted and the mortar allowed to remain in the mixing bowl for 90 s without covering. During the last 15 s of this interval, quickly scrape down into the batch the mortar that may have collected on the side of the bowl. Then remix for 15 s at medium speed.

10.3.3 Start molding the specimens within a total elapsed time of not more than 2 min and 30 s after completion of the original mixing of the mortar batch.

10.3.4 Evenly distribute a layer of mortar about 20 mm in thickness in each of the three molds with the tamper guide in place.