



Designation: ~~F1864~~—~~16~~ F1864 – 21

Standard Test Method for Dust Erosion Resistance of Optical and Infrared Transparent Materials and Coatings¹

This standard is issued under the fixed designation F1864; the number immediately following the designation indicates the year of original adoption or, in the case of revision, the year of last revision. A number in parentheses indicates the year of last reappraisal. A superscript epsilon (ϵ) indicates an editorial change since the last revision or reappraisal.

1. Scope

1.1 This test method covers the resistance of transparent plastics and coatings used in aerospace windscreens, canopies, and viewports to surface erosion as a result of dust impingement. This test method simulates flight through a defined particle cloud environment by means of independent control of particle size, velocity, impact angle, mass loading, and test duration.

1.2 *This standard does not purport to address all of the safety concerns, if any, associated with its use. It is the responsibility of the user of this standard to establish appropriate ~~safety~~ safety, health, and ~~health~~ environmental practices and determine the applicability of regulatory limitations prior to use.*

1.3 *This international standard was developed in accordance with internationally recognized principles on standardization established in the Decision on Principles for the Development of International Standards, Guides and Recommendations issued by the World Trade Organization Technical Barriers to Trade (TBT) Committee.*

2. Referenced Documents

2.1 ASTM Standards:²

D618 Practice for Conditioning Plastics for Testing

D1003 Test Method for Haze and Luminous Transmittance of Transparent Plastics

D1193 Specification for Reagent Water

E11 Specification for Woven Wire Test Sieve Cloth and Test Sieves

E168 Practices for General Techniques of Infrared Quantitative Analysis

3. Terminology

3.1 Definitions of Terms Specific to This Standard:

3.1.1 *mass loading, n*—the mass of dust per unit of total exposed surface area (including the sample holder) that impinges on the specimens.

3.1.2 *mean IR transmission, n*—for the purposes of this standard, the average percentage of light transmitted by a material in the ~~8–8~~ to ~~12– μ m~~ 12 μ m bandwidth.

3.1.3 *sweep time, n*—the time required for one translation pass.

¹ This test method is under the jurisdiction of ASTM Committee F07 on Aerospace and Aircraft and is the direct responsibility of Subcommittee F07.08 on Transparent Enclosures and Materials.

Current edition approved April 1, 2016 May 1, 2021. Published April 2016 May 2021. Originally approved in 1998. Last previous edition approved in 2010 as F1864–05 (2010); F1864–16. DOI: 10.1520/F1864-16.10.1520/F1864-21.

² For referenced ASTM standards, visit the ASTM website, www.astm.org, or contact ASTM Customer Service at service@astm.org. For Annual Book of ASTM Standards volume information, refer to the standard's Document Summary page on the ASTM website.

3.1.4 *translation pass, n*—the translation of the specimen platform from the vertical or horizontal limit to the corresponding vertical or horizontal limit.

3.1.5 *translation cycle, n*—the translation of the specimen platform from the vertical or horizontal limit to the corresponding vertical or horizontal limit and back to the initial vertical or horizontal limit. Two translation passes are equivalent to one translation cycle.

3.2 Symbols:

A_s = reference surface area of specimen platform (cm²),
 C_c = simulated cloud concentration (g/m³),
 h_o = percent haze before exposure,
 h_e = percent haze after exposure,
 m'_p = rate of particle mass impacting the reference surface area (g/min),
 m'_i = incremental mass loading (g/cm²),
 m_T = total mass loading (g/cm²),
 N = number of increments,
 V_p = particle impact velocity (m/s),
 t_s = sweep time(s),
 T_e = optical or mean infrared (IR) transmission after exposure (%),
 T_o = optical or mean IR transmission before exposure (%),
 α = impact angle (normal incidence = 90°),
 Δt_i = exposure time (min) for loading increment i ,
 ϕ_i = incremental dust load (g/cm²) for loading increment i ,
 Φ = total dust load (g/cm²),
 Δh = change in percent haze, and
 ΔT = change in optical or IR transmission.

4. Summary of Test Method

4.1 This test method consists of: (1) measuring and recording the light transmission properties, at visual or infrared wavelengths, of test coupons; (2) mounting the coupons in a test fixture; (3) exposing the coupons to a dust particle stream; and (4) remeasuring the light transmission properties to determine changes in these properties.

4.2 The dust particle stream simulates flight at a specified velocity through a dust cloud of specified density. Simulation is accomplished through control of particle size distribution, mean particle velocity, particle mass flow rate, and angle of impact.

4.3 The degree of abrasion is measured by the amount of change in haze and luminous transmittance for materials transparent in the visual wavelengths and by the amount of change in IR spectral transmission for materials transparent in the infrared wavelengths.

5. Significance and Use

5.1 All materials on exterior aircraft surfaces are subject to abrasion from airborne particles of various sizes and shapes. Transparent materials are particularly vulnerable to abrasion, since their performance is based on their ability to transmit light with a minimal amount of scatter. Scratches, pitting, and coating removal and delamination as a result of abrasion may increase scatter, reduce transmission, and degrade the performance of transparent materials. Visually transparent materials are required for pilot and air crew enclosures, such as canopies, windshields, and viewpoints. Materials transparent in the IR region (8 to 12 μm) are required for tracking, targeting, and navigational instrumentation.

5.2 This test method is intended to provide a calibrated and repeatable means of determining the relative abrasion resistance of materials and coatings for optical and IR transparent materials and coatings. The test parameters for this test method can be directly related to dust cloud densities and velocities to which transparent materials are exposed in the field.

6. Apparatus

6.1 *Dust Erosion Abrader*, as illustrated in Fig. 1. The test apparatus simulates flight through dust environments by blowing crushed silica particles, at a controlled mass flow rate and velocity, onto samples that are stationary in the direction of particle flow. The dust erosion abrader consists of four distinct subsystems: transport gas system, dust particle delivery system, dust velocity calibration system, and specimen platform.

6.1.1 The transport gas system carries the dust particles at specified velocity. The transport gas for the particles shall be dry air or nitrogen. The transport gas shall be controlled by a system of precision regulators and pressure transducers and routed through a nozzle which produces stable flow for the particle sizes and velocities of interest. Dust particles are accelerated to target velocities in a circular jet formed by the expansion of compressed gas in the nozzle. The nozzles conforming to Fig. 2 have been shown to produce stable flow for inlet pressures in the range 5.50 to 620 kPa (0.800 to 90.0 psi). The nozzle consists of converging-diverging sections, which accelerate the gas phase to supersonic speeds, and a constant diameter extension which provides sufficient resident time for particle acceleration. Fig. 3 shows typical stable velocities that can be achieved using the nozzle in Fig. 2. The nozzle mount shall include adjustments for convenient access to the specimen platform during mounting of the specimen holder and for positioning the nozzle a distance of 25.4 mm (1.00 in.) from the specimen after mounting.

6.1.2 The dust particle delivery system directs particles into the transport gas stream. The delivery system shall deliver uniform and consistent mass flow over the range of 0.200 to 10.0 g/min. The system consists of a pressurized holding container for the dust and a mechanism for directing the dust into the transport gas stream. A screw feeder system housed in a pressurized plenum (Fig. 4) has been demonstrated to provide the required mass flow. The particle delivery system shall possess control instrumentation separate from the transport gas control system so that mass flow rate of the dust can be is controlled independent of the transport gas velocity.

6.1.3 The dust velocity calibration system shall consist of a noninvasive velocity measurement system (VMS) such that particle velocity may be is calibrated to transport gas pressure and dust mass flow rate. The laser doppler velocimeter (LDV) shown in Figs. 5 and 6 has been demonstrated to provide the required velocity measurements. In-situ monitoring of velocity during dust exposure

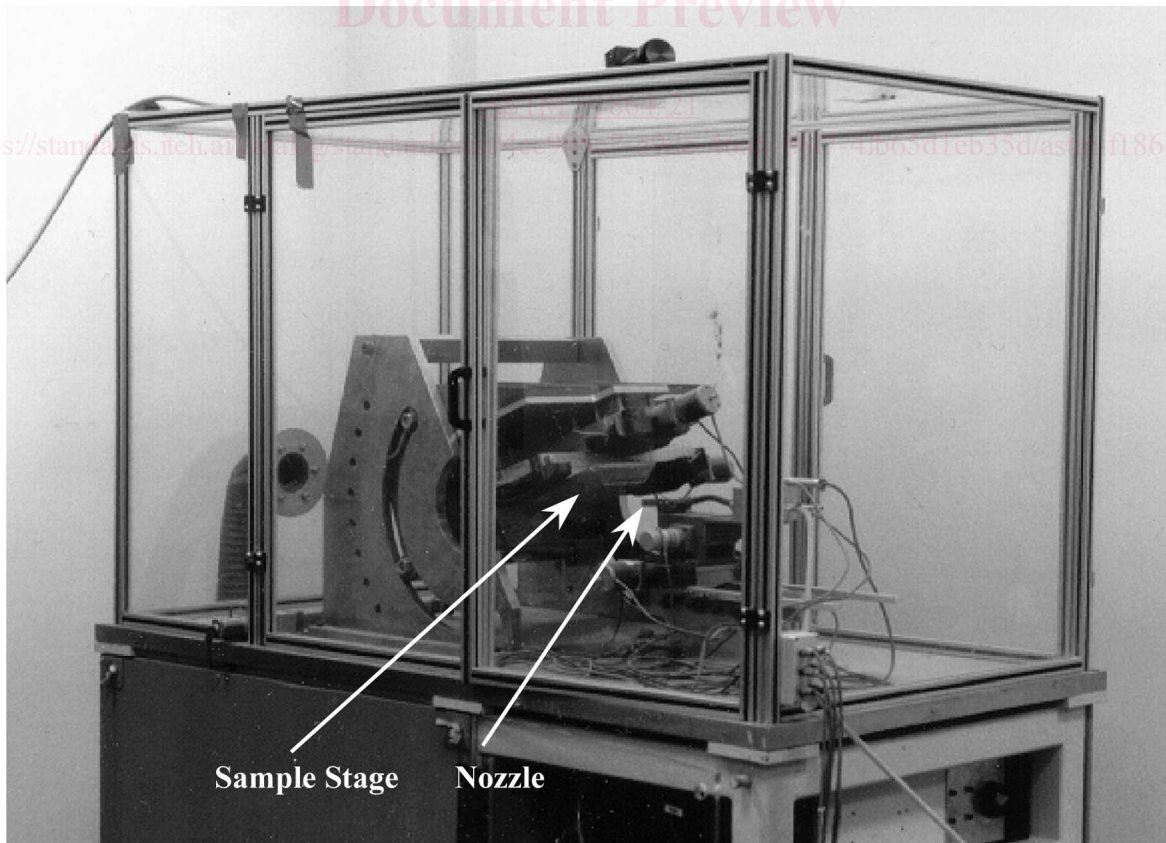
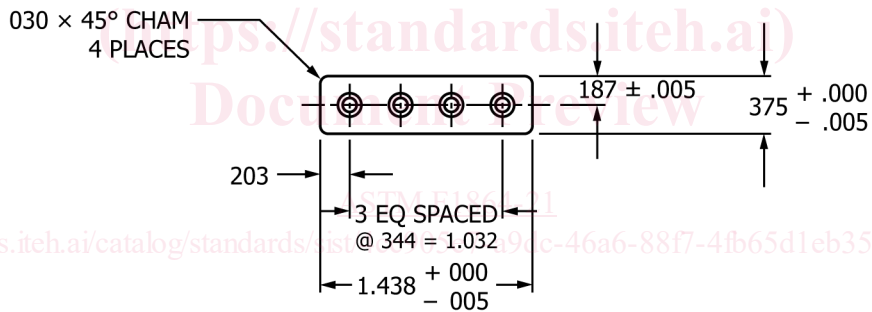
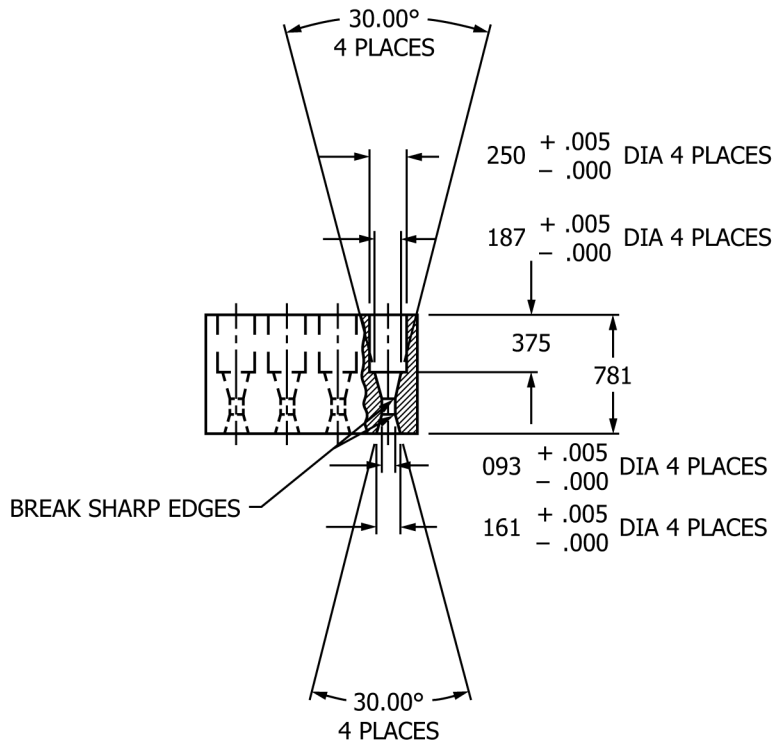

FIG. 1 Dust Erosion Chamber



1. MATERIAL AISI S2 TOOL STEEL

NOTES:

FIG. 2 Recommended Nozzle Configuration

is recommended. However, if the size or configuration of the noninvasive VMS prohibits in-situ monitoring, pre- and post-exposure calibration shall be conducted to ensure that the velocity/pressure calibration has remained valid through the test.

6.1.4 The specimen platform and test bed consists of stages and fixtures onto which test specimens and the nozzle are mounted. The test bed shall include adjustments such that dust particle incidence angles range from normal to 70° off-normal. Because the particle stream is substantially smaller than the specimen holder, the specimen platform shall translate both horizontally and vertically through the particle stream to ensure uniform coverage of all specimens. Screw-type mechanisms or stepper motors are recommended for platform translation. Translation rates shall be adjustable from 0 to 30 translation cycles per minute horizontally and 0 to 4 translation cycles per minute vertically. The translation range shall be sufficient to permit the outermost specimens to translate completely past the dust jet in all directions. The specimen platform shall accommodate a variety of test sample geometries. Samples ranging in size from 25.4 mm (1.00 in.) in diameter to 152 mm (6.00 in.) square have been exposed in the test bed shown in Fig. 7. The specimen platform shall include adjustment for convenient mounting of samples. Sample holders shall include a frontal mask to control the abraded area and prevent abrasion near sample edges. The frontal mask shall include tapered edges (Fig. 8) to direct the dust flow onto the sample.

6.2 A wire-cloth particle sieve shall be used to obtain specific particle-size ranges. A continuous flow vibrating sieve system (Fig.

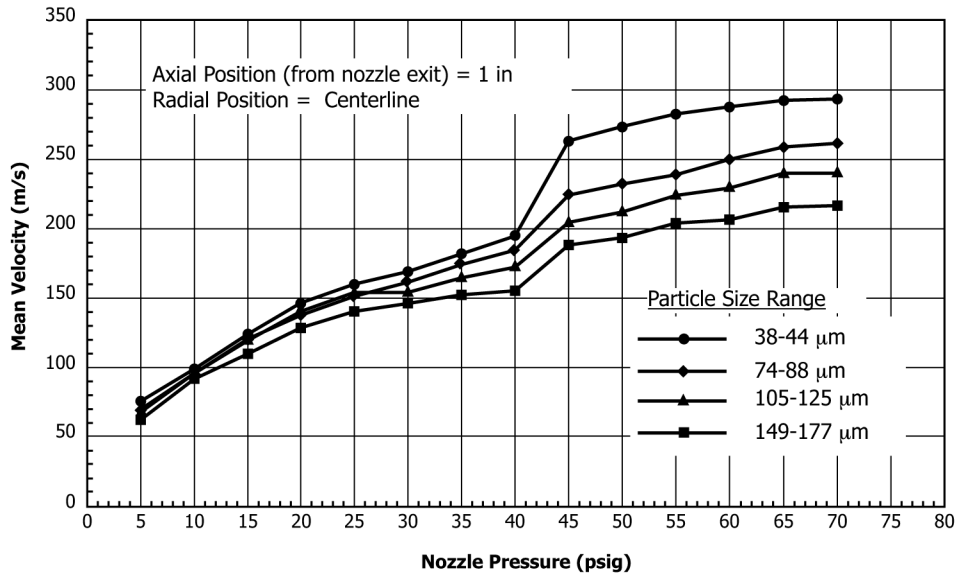

FIG. 3 Typical Velocity/Pressure Profile for Fig. 2 Nozzle

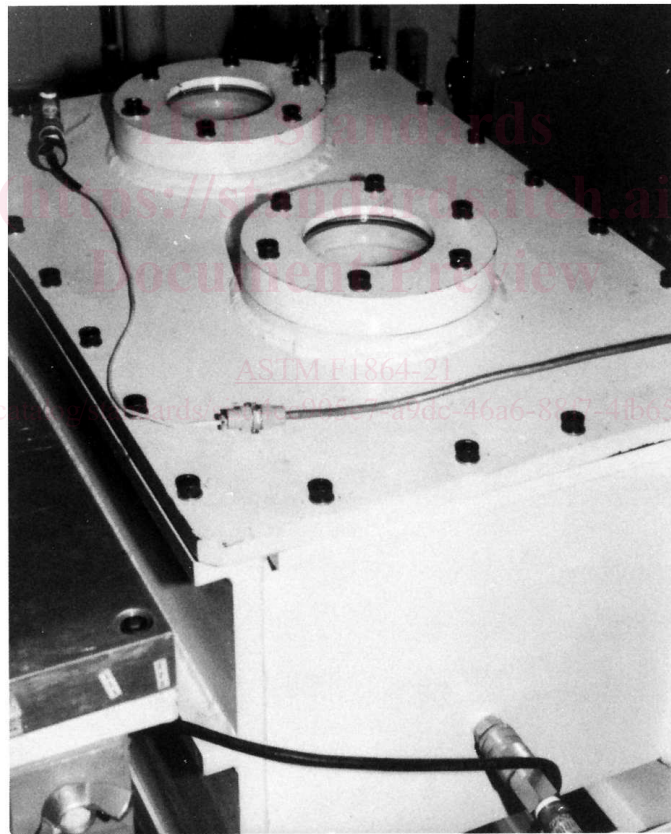

FIG. 4 Screw Feeder and Pressurized Plenum

9) is recommended for optimum and efficient sieving of bulk sand. Sieve nominal dimensions and permissible variations shall comply with the U.S.A. Standard Test Sieves Standard Series as detailed in Specification E11.

6.3 Integrating Sphere Photoelectric Photometer, as described in Test Method D1003, shall be used to measure the light transmitted and scattered by the abraded surface of optically transparent materials and coatings.

6.4 Fourier Transform Infrared (FTIR) Spectrometer shall be used to measure the IR transmission properties of IR transparent

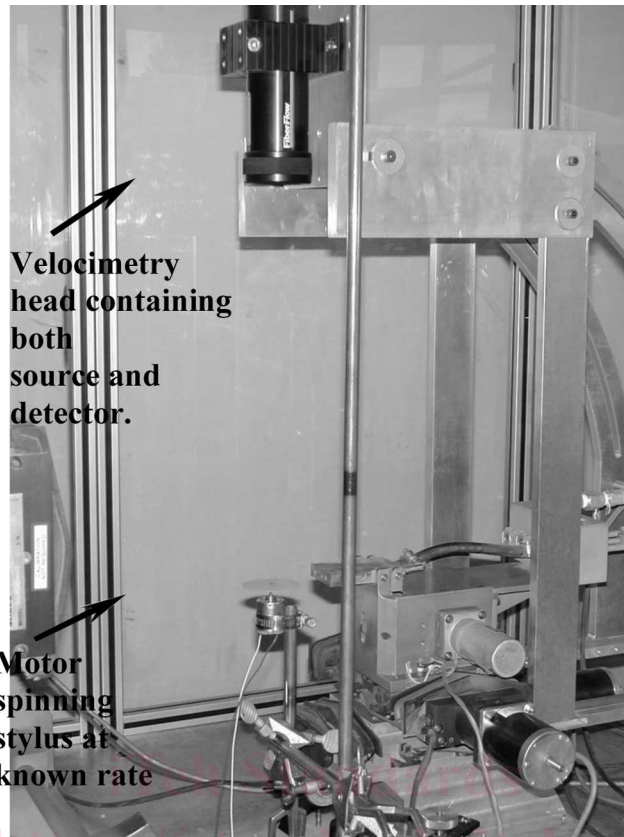

FIG. 5 Laser Doppler Velocimeter Calibration



FIG. 6 Laser Doppler Power Supply and Instrumentation

materials and coatings. The spectrometer shall be capable of measuring percent transmission in the 8-8 to ~~12- μm~~ 12 μm bandwidth. A number of self-contained commercial FTIR systems existing on the market have been demonstrated to provide the required measurements. Spectrometers used in this test method shall comply with applicable sections of Practice E168.

7. Materials and Reagents

7.1 *Purity of Water*—Unless otherwise indicated, references to water shall be understood to mean reagent water as defined by Type II of Specification D1193.

7.2 *Crushed Silica Sand*—The dust particles shall consist of crushed silica sand. The sand shall be dry, nonclogging, and have corners and edges that have not been rounded by other than the crushing process. Bulk dust particle sizes shall be uniformly distributed in the range 10 to 250 μm .

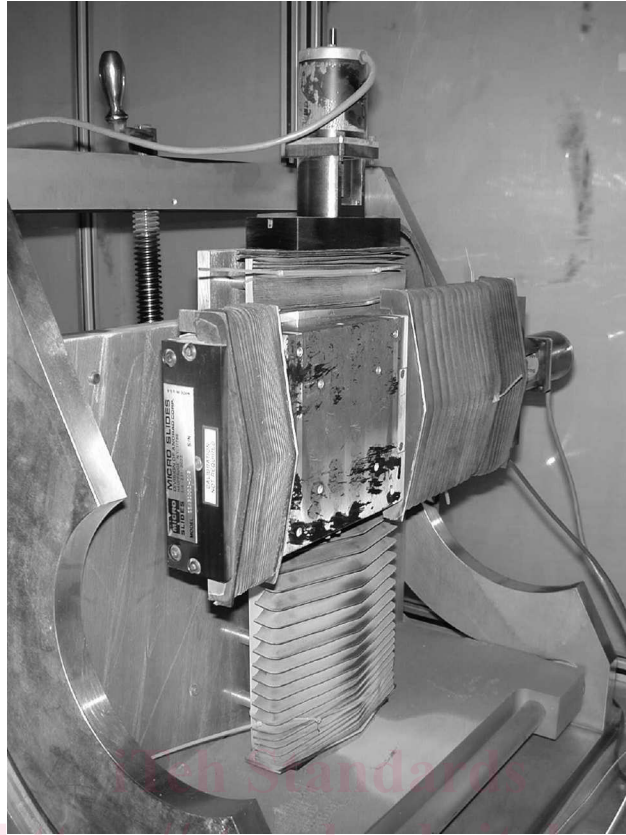

FIG. 7 Dust Erosion Test Bed with Programmable Stepper Motors

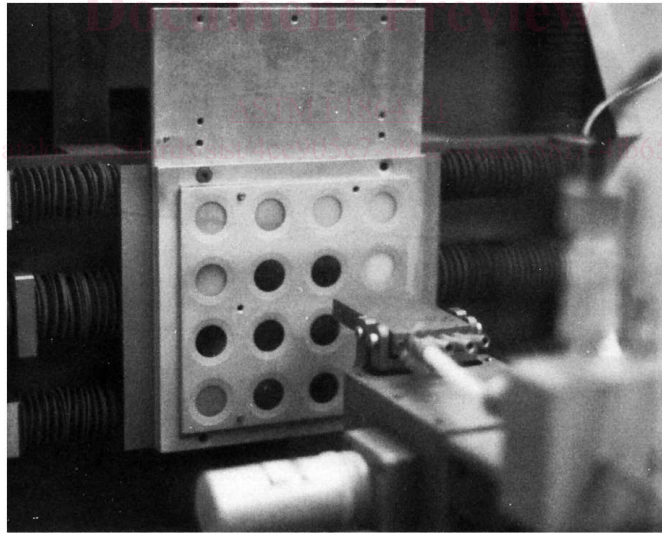

FIG. 8 Typical Frontal Mask

7.3 *Compressed Air or Nitrogen*—The transport gas shall be dry and pressurized to a minimum of 827 kPa (120 psi) at the source.

7.4 *Isopropyl Alcohol Solution*—Mix isopropyl alcohol (C_3H_7OH) with water in a volumetric ratio of 1:1.

8. Test Specimens

8.1 *Optically Transparent Materials*—Test specimens shall be clean flat samples of the material or substrate/coating system to be