



Designation: ~~D6393~~—14 D6393/D6393M – 21

Standard Test Method for Bulk Solids Characterization by Carr Indices¹

This standard is issued under the fixed designation ~~D6393~~D6393/D6393M; the number immediately following the designation indicates the year of original adoption or, in the case of revision, the year of last revision. A number in parentheses indicates the year of last reapproval. A superscript epsilon (ϵ) indicates an editorial change since the last revision or reapproval.

1. Scope*

1.1 This test method covers an apparatus and procedures for measuring properties of bulk solids, henceforth referred to as Carr Indices.²

1.2 This test method is suitable for free flowing and moderately cohesive powders and granular materials up to 2.0 mm [$\frac{1}{16}$ in.] in size. Materials must be able to pour through a 6.0 to 8.0-mm [$\frac{1}{4}$ to $\frac{5}{16}$ in.] diameter funnel outlet when in an aerated state.

1.3 This method consists of eight measurements and two calculations for Carr Indices as follows. Each measurement, or calculation, or combination of them, can be used to characterize the properties of bulk solids.

1.3.1 Measurement of Carr Angle of Repose

1.3.2 Measurement of Carr Angle of Fall

1.3.3 Calculation of Carr Angle of Difference

1.3.4 Measurement of Carr Loose Bulk Density

<https://standards.iteh.ai/catalog/standards/sist/9a1d6bf5-de5c-47d1-b35c-def8a3d9ecc7/astm-d6393-d6393m-21>

1.3.5 Measurement of Carr Packed Bulk Density

1.3.6 Calculation of Carr Compressibility

1.3.7 Measurement of Carr Cohesion

1.3.8 Measurement of Carr Uniformity

1.3.9 Measurement of Carr Angle of Spatula

1.3.10 Measurement of Carr Dispersibility

1.4 All observed and calculated values shall conform to the guidelines for significant digits and rounding established in Practice **D6026**.

¹ This test method is under the jurisdiction of ASTM Committee **D18** on Soil and Rock and is the direct responsibility of Subcommittee **D18.24** on Characterization and Handling of Powders and Bulk Solids.

Current edition approved ~~Nov. 1, 2014~~ May 1, 2021. Published ~~November 2014~~ May 2021. Originally approved in 1999. Last previous edition approved in ~~2008~~ 2014 as ~~D6393—08~~ D6393 – 14, DOI: ~~10.1520/D6393-14~~ 10.1520/D6393_D6393M-21.

² Carr, R.L., "Evaluating Flow Properties of Solids," *Chemical Engineering*, January 18, 1965, pp. 163–168.

***A Summary of Changes section appears at the end of this standard**



1.4.1 The procedures used to specify how data are collected/recorded or calculated in this standard are regarded as the industry standard. In addition, they are representative of the significant digits that generally should be retained. The procedures used do not consider material variation, purpose for obtaining the data, special purpose studies, or any considerations for the user's objectives; and it is common practice to increase or reduce significant digits of reported data to be commensurate with these considerations. It is beyond the scope of this standard to consider significant digits used in analysis methods for engineering design.

1.5 *Units*—The values stated in either SI units or inch-pound units are to be regarded as standard. ~~No other units of measurement are included in this standard.~~ separately as standard. The values stated in each system are not necessarily exact equivalents; therefore, to ensure conformance with the standard, each system shall be used independently of the other, and values from the two systems shall not be combined.

1.6 *This standard does not purport to address all of the safety concerns, if any, associated with its use. It is the responsibility of the user of this standard to establish appropriate safety, health, and environmental practices and determine the applicability of regulatory limitations prior to use.*

1.7 *This international standard was developed in accordance with internationally recognized principles on standardization established in the Decision on Principles for the Development of International Standards, Guides and Recommendations issued by the World Trade Organization Technical Barriers to Trade (TBT) Committee.*

2. Referenced Documents

2.1 ASTM Standards:³

D653 Terminology Relating to Soil, Rock, and Contained Fluids

D2216 Test Methods for Laboratory Determination of Water (Moisture) Content of Soil and Rock by Mass

D3740 Practice for Minimum Requirements for Agencies Engaged in Testing and/or Inspection of Soil and Rock as Used in Engineering Design and Construction

D6026 Practice for Using Significant Digits in Geotechnical Data

E11 Specification for Woven Wire Test Sieve Cloth and Test Sieves

3. Terminology

3.1 Definitions of Terms:

3.1.1 For ~~common~~ definitions of common technical terms in this test method, standard, refer to Terminology D653.

3.2 Definitions of Terms Specific to This Standard:

3.2.1 *Carr Indices, n—in storing, handling and processing bulk solids using industrial equipment,* a series of ten values obtained using the Hosokawa Micron Powder Characteristics Tester.

3.2.2 *Carr Angle of Repose, n—in storing, handling and processing bulk solids using industrial equipment,* a Carr Index that denotes the slope of a pile formed using the Hosokawa Micron Powder Characteristics Tester

3.2.3 *Carr Angle of Fall, n—in storing, handling and processing bulk solids using industrial equipment,* a Carr Index that denotes the slope of a pile after applying shock impacts using the Hosokawa Micron Powder Characteristics Tester

3.2.4 *Carr Angle of Difference, n—in storing, handling and processing bulk solids using industrial equipment,* a Carr Index calculated by subtracting Carr Angle of Fall from Carr Angle of Repose

3.2.5 *Carr Loose Bulk Density, n—in storing, handling and processing bulk solids using industrial equipment,* a Carr Index that denotes the mass of loose powder in a given volume using the Hosokawa Micron Powder Characteristics Tester

3.2.6 *Carr Packed Bulk Density, n—in storing, handling and processing bulk solids using industrial equipment,* a Carr Index that denotes the mass of packed powder in a given volume using the Hosokawa Micron Powder Characteristics Tester

³ For referenced ASTM standards, visit the ASTM website, www.astm.org, or contact ASTM Customer Service at service@astm.org. For *Annual Book of ASTM Standards* volume information, refer to the standard's Document Summary page on the ASTM website.



3.2.7 Carr Compressibility, n —in storing, handling and processing bulk solids using industrial equipment, a Carr Index calculated based on the Carr Loose Bulk Density and Carr Packed Bulk Density.

3.2.8 Carr Cohesion, n —in storing, handling and processing bulk solids using industrial equipment, a Carr Index that is a descriptive measure of inter-particle forces based on the rate at which particles pass through sieves using the Hosokawa Micron Powder Characteristics Tester.

3.2.9 Carr Uniformity, n —in storing, handling and processing bulk solids using industrial equipment, a Carr Index that is chosen when Carr Cohesion measurement is not recommended. It is determined by measuring the particle size distribution of the powder specimen using sieve analysis with suitable sieve screens using the Hosokawa Micron Powder Characteristics Tester.

3.2.10 Carr Angle of Spatula, n —in storing, handling and processing bulk solids using industrial equipment, a Carr Index that is an average angle of powder pile in relation to the edge of a spatula before and after applying shock impacts using the Hosokawa Micron Powder Characteristics Tester.

3.2.11 Carr Dispersibility, n —in storing, handling and processing bulk solids using industrial equipment, a Carr Index is determined by dropping a powder specimen through a hollow cylinder above a watch glass using the Hosokawa Micron Powder Characteristics Tester.

4. Summary of Test Method

4.1 Carr Angle of Repose is determined by dropping the powder specimen through a vibrating sieve and funnel above a horizontal circular platform and measuring the angle of powder cone in relation to the edge of the circular platform.

4.2 Carr Angle of Fall is determined by measuring the angle of powder cone in relation to the edge of a circular platform after applying shock impacts to the powder cone. The measurement is performed after completing the measurement of Carr Angle of Repose.

4.3 Carr Angle of Difference is calculated by subtracting Carr Angle of Fall from Carr Angle of Repose.

4.4 Carr Loose Bulk Density is determined by sieving powder specimen through a vibrating chute to fill a measuring cup and calculating the mass of loose powder in a given volume.

4.5 Carr Packed Bulk Density is determined by dropping a measuring cup filled with powder specimen for a specific number of times from the same height and calculating the mass of packed powder in a given volume.

4.6 Carr Compressibility is a calculation based on the Carr Loose Bulk Density and Carr Packed Bulk Density.

4.7 Carr Cohesion is a descriptive measure of inter-particle forces based on the rate at which particles pass through sieves. It is determined by measuring the mass of powder on each sieve after vibrating it with powder specimen for a specific period of time. Sieve selection and its vibration time are determined based on the Carr Loose Bulk Density and Carr Packed Bulk Density.

4.8 Carr Uniformity is chosen when Carr Cohesion measurement is not recommended. It is determined by measuring the particle size distribution of the powder specimen using sieve analysis with suitable sieve screens that cover the particle size range of the powder specimen, then calculating the ratio of particle sizes which corresponding to 60% of powder by volume passing to that of 10 % of powder by volume passing.

4.9 Carr Angle of Spatula is an average angle of powder pile in relation to the edge of a spatula before and after applying shock impacts. The powder pile on the spatula is formed by covering the spatula with a specific volume of powder specimen on a pan, then lowering the pan to expose the spatula with a considerable amount of powder on it.

4.10 Carr Dispersibility is determined by dropping a powder specimen through a hollow cylinder above a watch glass, then measuring the mass of powder collected by the watch glass.

5. Significance and Use

5.1 This test method provides measurements that can be used to describe the bulk properties of a powder or granular material.

5.2 The measurements can be combined with practical experience to provide relative rankings of various forms of bulk handling behavior of powders and granular materials for a specific application.

NOTE 1—The quality of the result produced by this standard is dependent on the competence of the personnel performing it, and the suitability of the equipment and facilities used. Agencies that meet the criteria of Practice D3740 are generally considered capable of competent and objective testing/sampling/inspection/etc. Users of this standard are cautioned that compliance with Practice D3740 does not in itself assure reliable results. Reliable results depend on many factors; Practice D3740 provides a means of evaluating some of those factors. Practice D3740 was developed for agencies engaged in the testing or inspection (or both) of soil and rock. As such it is not totally applicable to agencies performing this standard. However, users of this standard should recognize that the framework of Practice D3740 is appropriate for evaluating the quality of an agency performing this standard. Currently there is no known qualifying national authority that inspects agencies that perform this standard.

6. Apparatus

6.1 *Powder Characteristics Tester*—The main instrument includes a *timer/counter* (A), a *vibrating mechanism* (B), an *amplitude gauge* (C), a *rheostat* (D), and a *tapping device* (E) (see Fig. 1).⁴

6.1.1 *Timer/Counter*—The timer is used to control the duration of vibration and the number of taps. A minimum 180-s timer for 60 Hz power supply or a counter is necessary.

6.1.2 *Vibrating Mechanism*, to deliver vibration at 50 to 60 Hz to the vibration plate at an amplitude of 0.0 to 3.0 mm [0 to 1/8 in.].

6.1.3 *Amplitude Gauge*, mounted on the vibration plate to measure the amplitude of the vibration from 0.0 to 4.0 mm [0 to 0.16 in.].

6.1.4 *Rheostat*—A dial used to adjust the vibration amplitude of vibration plate from 0.0 to 3.0 mm [0 to 1/8 in.].

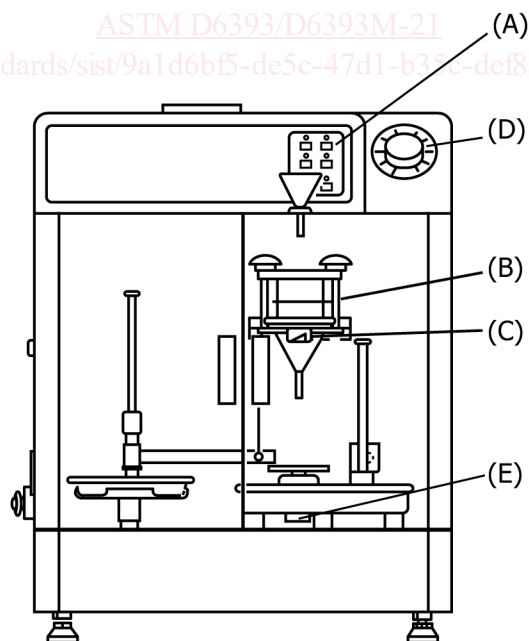

FIG. 1 Powder Characteristics Tester for Carr Indices

⁴ The sole source of supply of the apparatus known to the committee at this time is Hosokawa Micron International Inc., 10 Chatham Road, Summit, NJ. If you are aware of alternative suppliers, please provide this information to ASTM International Headquarters. Your comments will receive careful consideration at a meeting of the responsible technical committee,¹ which you may attend.

6.1.5 *Tapping Device*, consists of tap holder and tapping lift bar (tapping pin), which lifts and free-fall drops a measuring cup a stroke of 18.0 ± 0.1 mm [0.71 ± 0.004 in.] at a rate of 1.0 ± 0.2 taps/s.

6.2 *Carr Spatula Assembly*—The spatula assembly consists of a *spatula blade* (A), a *pan base/elevator stand* (B), and a *spatula shocker* (C) (see Fig. 2).

6.2.1 *Spatula Blade*—A chrome-plated brass plate mounted on the blade receiver to retain powder while the elevator stand lowers the powder-filled pan. The dimensions of the spatula blade are 80 to 130 mm [3 to 5 in.] length, 21.0 to ~~23.0 mm~~ 23.0 mm [0.83 to 0.91 in.] width and 3.0 to ~~6.0 mm~~ 6.0 mm [$1/8$ to $1/4$ in.] thick.

6.2.2 *Spatula Shocker*—A sliding bushing with a mass of 109.0 to 111.0 g [0.240 to 0.245 lbm] and a drop height of 140.0 to 160.0 ~~mm, mm~~ [$5\frac{1}{2}$ to $6\frac{1}{4}$ in.], measured from the lower edge of the bushing to the shocker base for the measurement of Carr Angle of Spatula. The total mass of the shocker assembly including the sliding bushing, pole, spatula blade, and blade receiver is 0.3 to 1.0 kg [0.66 to 2.20 lbm] depending on the material of construction.

6.3 A dispersibility measuring unit consists of a *container* (A) with *shutter cover* (B), a *cylindrical glass tube* (C), and a *watch glass* (D), (see Fig. 3).

6.3.1 *Container*—A hopper unit with a shutter cover at the bottom to support a powder specimen. The shutter cover opens horizontally to release the powder specimen, which then falls through the glass tube onto the watch glass.

6.3.2 *Cylindrical Glass Tube*, located vertically 160 to 180 mm [$6\frac{1}{4}$ to 7 in.] under the shutter cover to confine the scattering/dispersed powder. The dimension of the tube is 90 to ~~110 mm~~ 110 mm [$3\frac{1}{2}$ to $4\frac{1}{4}$ in.] diameter and 320 to ~~360 mm~~ 360 mm [$12\frac{1}{2}$ to 14 in.] length.

6.3.3 *Watch Glass*, centered 100 to 105 mm [$3\frac{7}{8}$ to $4\frac{1}{8}$ in.] under the cylindrical glass tube to collect undispersed powder. The dimension of watch glass is 90 to ~~110 mm~~ 110 mm [$3\frac{1}{2}$ to $4\frac{1}{4}$ in.] diameter and about ~~2.0 mm~~ 2.0 mm [$1/16$ in.] thickness with the radius of curvature of about 96.3 ~~mm, mm~~ [3.79 in.], concave upwards.

6.4 *Accessories*:

6.4.1 *Spatula Pan*—A stainless steel pan with at least a ~~100.0 mm~~ 100.0 mm [$3\frac{7}{8}$ in.] width, a ~~125.0 mm~~ 125.0 mm [5 in.] length, a 25.0 mm [1 in.] height, and a ~~1.0 mm~~ 1.0 mm [$1/32$ in.] thickness, used to retain powder for the preparation of the measurement of Carr Angle of Spatula.

6.4.2 *Scoop*—A stainless steel container used to transport powder.

6.4.3 *Scraper*—A chrome plated brass or stainless steel plate used to scrape off excess powder in the cup.

6.4.4 *Cup*—A ~~100-cm~~ 100 cm³ [6 in.³] stainless steel cylindrical container with the inside dimensions of 49.9 to ~~50.1 mm~~ 50.1 mm

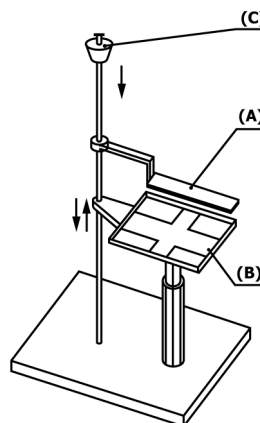

FIG. 2 Carr Spatula Assembly

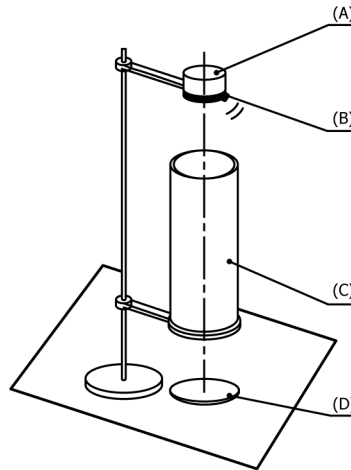

FIG. 3 Carr Dispersibility Measuring Unit

[1.96 to 1.97 in.] diameter and 49.9 to 50.1 mm [1.96 to 1.97 in.] height used for Carr Bulk Density measurement. The wall thickness of the cup is 1.3 to 2.3 mm [0.05 to 0.09 in.]. The interior walls of the cup shall be sufficiently smooth that machining marks are not evident.

6.4.5 *Cup Extension*—A white ~~Delrin (trademarked)~~ polyoxymethylene extension sleeve for the 100 cm³ [6 in.³] measuring cup, 53.0 to 55.0 mm [2.09 to 2.17 in.] in diameter by 47.0 to 49.0 mm [1.85 to 1.93 in.] in height.

6.4.6 *Funnel for Carr Angle of Repose*—A glass funnel with a 65° ± 5° angle bowl as measured from the horizontal, 6.0 to 8.0 mm [¹/₄ to ⁵/₁₆ in.] bottom outlet diameter and outlet stem length 32.0 to 36.0 mm [1.26 to 1.42 in.] for the measurement of Carr Angle of Repose.

6.4.7 *Stationary Chute*—A stainless steel conical chute with the dimensions of 73.0 to 77.0 mm [2.87 to 3.03 in.] top diameter, 53.0 to 57.0 mm [2.09 to 2.24 in.] height, and 48.0 to 52.0 mm [1.89 to 2.05 in.] bottom diameter to guide the powder flow into the measuring cup (see 6.4.4).

6.4.8 *Vibration Chute*—A stainless steel conical chute with the dimensions of 73.0 to 77.0 mm [2.87 to 3.03 in.] top diameter, 53.0 to 57.0 mm [2.09 to 2.24 in.] height, and 48.0 to 52.0 mm [1.89 to 2.05 in.] bottom diameter installed on the vibration plate to guide the powder flow to the stationary chute or cup extension.

6.4.9 *Sieves*, certified ~~76.0 mm~~ 76.0 mm [3 in.] diameter stainless steel sieves with openings of 710 μm, 355 μm, 250 μm, 150 μm, 75 μm, and 45 μm (No. 25), 355 μm (No. 45), 250 μm (No. 60), 150 μm (No. 100), 75 μm (No. 200), and 45 μm (No. 325) conforming to Specification E11 (0.028, 0.014, 0.010, 0.006, 0.003, and 0.002 in.).

6.4.10 *Sieve Extension*—A stainless steel extension piece used as a spacer in the vibration unit when only one sieve is used.

6.4.11 *Spacer Ring*—A white ~~Delrin (trademarked)~~ polyoxymethylene spacer inserted between sieve and vibration chute or glass funnel to protect them from damage.

6.4.12 *Sieve Holding Bar*—A chrome-plated brass holding bar used to hold sieve assembly on the vibration plate.

6.4.13 *Pan*, with base for tapping device, measuring cup, and shocker. A stainless steel pan, at least ~~200 mm length~~, 140 mm ~~200 mm~~ [8 in.] length, 140 mm [⁵/₂ width, ~~30 mm~~ in.] width, 30 mm [1 ¹/₄ in.] height, and ~~1.0 mm~~ 1.0 mm [¹/₃₂ in.] thickness, designed to accept tapping device, measuring cup and platform, as well as provide a stand base for shocker.

NOTE 2—The pan has molded-in feet so it is slightly raised from the table top. This helps make vibration more consistent.

6.4.14 *Platform*—A chrome-plated brass circular platform with a diameter of 79.0 to 81.0 mm [3.11 to 3.19 in.] and a height of 58.0 to 62.0 mm [2 ¹/₄ to 2 ¹/₂ in.] to be used for the measurement of Carr Angle of Repose.

6.4.15 *Shocker*—A sliding bushing with a mass of 109.0 to 111.0 g [0.240 to 0.245 lbm] at a drop height of 140.0 to 160.0 mm;

mm [5½ to 6¼ in.], measured from the lower edge of the bushing to the shocker base for the measurement of Carr Angle of Fall. The total mass of the shocker, platform, and pan for the measurement of angle of fall is 1.1 to 1.6 ~~kg~~-kg [2.4 to 3.5 lbm].

6.4.16 *Brush*, a laboratory brush for dust removal.

6.4.17 *Cover*, for measuring Carr Dispersibility. A removable enclosure to confine the dust of specimen powder when it falls onto the watch glass for the measurement of Carr Dispersibility.

6.5 *Balance*, capable of measuring specimen mass to an accuracy of ~~± 0.01 g~~ ± 0.01 g [0.00002 lbm] with a max of 2.0 ~~kg~~-kg [4.4 lbm].

6.6 *Scale (ruler)*, with mm [in.] increments, at least 150 mm [6 in.] long.

6.7 *Data Acquisition Equipment*—A microprocessor or computer may be used to guide the measuring operation, collect data, calculate data, and print test results.

6.8 A properly calibrated photo image of the powder cone can be used for relevant measurement.

7. Procedure

7.1 ~~A Carefully riffle~~ a representative powder sample from process stream ~~should be riffled carefully~~ into enough specimens, one for each individual measurement.

7.2 ~~All~~ Perform all the measurements ~~should be performed~~ on a strong, horizontally-leveled bench or work table. If practicable, use a concrete or stone-topped table.

7.3 *Measurement of Carr Angle of Repose:*

7.3.1 Place the parts onto the vibration plate in the following order starting at the bottom:

7.3.1.1 Glass funnel;

7.3.1.2 Spacer ring;

7.3.1.3 Sieve with opening of 710 ~~μm~~ μm (No. 25);

7.3.1.4 Sieve extension; and,

7.3.1.5 Sieve holding bar.

7.3.2 Fasten the vibration assembly with knob nuts located on both sides of sieve holding bar.

7.3.3 Center the platform under the glass funnel.

7.3.4 Position the stem end of the glass funnel 75.0 to 77.0 mm [2.95 to 3.03 in.] above the platform.

7.3.5 Set desired vibration time on timer (usually 180 s on 60 Hz vibrating frequency is selected).

7.3.6 Pour 200 to 300 cm³ [12 to 18 in.³] of powder over the sieve using the scoop.

7.3.7 Set Rheostat to 0.

7.3.8 Turn on the vibrating mechanism and timer.

7.3.9 Gradually increase the amplitude of the vibration, no more than 0.2 mm [0.008 in.] at a time, by incrementally turning the Rheostat until powder starts to flow out of the end of the glass funnel and builds up on the circular platform in a conical shape.