



Designation: D7698 – 21

# Standard Test Method for In-Place Estimation of Density and Water Content of Soil and Aggregate by Correlation with Complex Impedance Method<sup>1</sup>

This standard is issued under the fixed designation D7698; the number immediately following the designation indicates the year of original adoption or, in the case of revision, the year of last revision. A number in parentheses indicates the year of last reapproval. A superscript epsilon ( $\epsilon$ ) indicates an editorial change since the last revision or reapproval.

## 1. Scope\*

1.1 *Purpose and Application*—This test method describes the procedure, equipment, and interpretation methods for estimating in-place soil dry density and water content using a Complex-Impedance Measuring Instrument (CIMI).

1.1.1 The purpose and application of this test method is for testing porous material such as used in roadway base or building foundations that may be deployed in the field at various test sites. The test apparatus includes electrodes that contact the porous material under test and a sensor unit that supplies electromagnetic signals to the porous material. Response signals reveal electrical parameters such as complex impedance which can be equated to material properties such as density and moisture content.

1.1.2 CIMI measurements as described in this test method are applicable to measurements of compacted soils intended for roads and foundations.

1.1.3 This test method describes the procedure for estimating in-place density and water content of soils and soil-aggregates by use of a CIMI. The electrical properties of the soil are measured using a radio frequency (RF) voltage source connected to soil electrical probes driven into the soils and soil-aggregates to be tested, in a prescribed pattern and depth. Certain algorithms of these properties are related to wet density and water content. This correlation between electrical measurements, and density and water content is accomplished using a calibration methodology. In the calibration methodology, density and water content are determined by other ASTM Test Standards that measure soil density and water content, thereafter correlating the corresponding measured electrical properties to the soil physical properties.

1.2 *Units*—The values stated in SI units are to be regarded as standard. The inch-pound units given in parentheses are

mathematical conversions which are provided for information purposes only and are not considered standard.

1.2.1 All observed and calculated values shall conform to the guidelines for significant digits and rounding established in Practice **D6026** unless superseded by this standard.

### 1.3 *Generalized Theory:*

1.3.1 Two key electrical properties of soil are conductivity and relative dielectric permittivity which are manifested as a value of complex-impedance that can be determined.

1.3.2 The soil conductivity contributes primarily to the real component of the complex-impedance, and the soil relative dielectric permittivity contributes primarily to the imaginary component of the complex-impedance.

1.3.3 The complex-impedance of soil can be determined by placing two electrodes in the soil to be tested at a known distance apart and a known depth. The application of a known frequency of alternating current to the electrodes enables a measurement of current through the soil, voltage across the electrodes, and the electrical phase difference between the voltage and current. Complex-impedance is calculated from these known and measured parameters.

1.3.4 From the determined complex-impedance, an electrical network consisting of a resistor (R) and capacitor (C) connected in parallel are used to represent a model of the soil being tested.

1.3.5 Relationships can be made between the soil wet density and the magnitude of the complex-impedance, and also between the soil water mass per unit measured, and the quotient of the values of C and R using a Soil Model process.

1.3.6 The Soil Model process results in mathematical relationships between the physical and electrical characteristics of the soil which are used for soil-specific calibration of the CIMI.

1.3.7 Refer to **Appendix X1** for a more detailed explanation of complex-impedance measurement of in-place soil, and its use in field measurements for the estimation of dry density and water content.

### 1.4 *Precautions:*

1.4.1 The low-level RF output power levels of the CIMI method are harmless.

<sup>1</sup> This test method is under the jurisdiction of ASTM Committee **D18** on Soil and Rock and is the direct responsibility of Subcommittee **D18.08** on Special and Construction Control Tests.

Current edition approved May 1, 2021. Published May 2021. Originally approved in 2011. Last previous edition approved in 2020 as D7698–20. DOI: 10.1520/D7698-21.

\*A Summary of Changes section appears at the end of this standard

1.4.2 The SI units presented for apparatus are substitutions of the inch-pound units, other similar SI units should be acceptable providing they meet the technical requirements established by the inch-pound apparatus.

1.5 *This standard does not purport to address all of the safety concerns, if any, associated with its use. There are no known hazards associated with this standard. It is the responsibility of the user of this standard to establish appropriate safety, health, and environmental practices and determine the applicability of regulatory limitations prior to use.*

1.6 *This international standard was developed in accordance with internationally recognized principles on standardization established in the Decision on Principles for the Development of International Standards, Guides and Recommendations issued by the World Trade Organization Technical Barriers to Trade (TBT) Committee.*

## 2. Referenced Documents

### 2.1 ASTM Standards:<sup>2</sup>

**D653** Terminology Relating to Soil, Rock, and Contained Fluids

**D698** Test Methods for Laboratory Compaction Characteristics of Soil Using Standard Effort (12,400 ft-lbf/ft<sup>3</sup> (600 kN-m/m<sup>3</sup>))

**D1556** Test Method for Density and Unit Weight of Soil in Place by Sand-Cone Method

**D1557** Test Methods for Laboratory Compaction Characteristics of Soil Using Modified Effort (56,000 ft-lbf/ft<sup>3</sup> (2,700 kN-m/m<sup>3</sup>))

**D2216** Test Methods for Laboratory Determination of Water (Moisture) Content of Soil and Rock by Mass

**D3740** Practice for Minimum Requirements for Agencies Engaged in Testing and/or Inspection of Soil and Rock as Used in Engineering Design and Construction

**D4253** Test Methods for Maximum Index Density and Unit Weight of Soils Using a Vibratory Table

**D4643** Test Method for Determination of Water Content of Soil and Rock by Microwave Oven Heating

**D4718** Practice for Correction of Unit Weight and Water Content for Soils Containing Oversize Particles

**D4944** Test Method for Field Determination of Water (Moisture) Content of Soil by the Calcium Carbide Gas Pressure Tester

**D6026** Practice for Using Significant Digits in Geotechnical Data

**D7382** Test Methods for Determination of Maximum Dry Unit Weight of Granular Soils Using a Vibrating Hammer

**E691** Practice for Conducting an Interlaboratory Study to Determine the Precision of a Test Method

## 3. Terminology

3.1 *Definitions*—For definitions of common technical terms used in this standard, refer to Terminology **D653**.

<sup>2</sup> For referenced ASTM standards, visit the ASTM website, [www.astm.org](http://www.astm.org), or contact ASTM Customer Service at [service@astm.org](mailto:service@astm.org). For *Annual Book of ASTM Standards* volume information, refer to the standard's Document Summary page on the ASTM website.

### 3.2 Definitions of Terms Specific to This Standard:

3.2.1 *complex impedance, n*—the ratio of the phasor equivalent of a steady-state sine-wave or voltage like quantity (driving force) to the phasor equivalent of a steady-state sine-wave current of current like quantity (response).<sup>3</sup>

3.2.2 *relative permittivity, n*—the permittivity of the material relative to that of free space.<sup>4</sup>

3.2.3 *phase relationship, n*—the electrical phase difference between the applied probe-to-probe RF voltage, and the resulting soil current.

3.2.4 *probe-to-probe RF voltage, n*—the peak value of RF voltage measured across two probes that are conducting soil current.

3.2.5 *soil capacitance, n*—the value of the capacitor in an equivalent parallel resistor-capacitor circuit that results from the probe-to-probe RF voltage, current in the soil, and resulting phase relationship due to the application of a RF voltage source applied to the probes.

3.2.6 *soil current, n*—the peak value of the RF current passing through the soil from one probe electrode to another.

3.2.7 *Soil Model, n*—the result of a calibration procedure that establishes a correlating linear function between measured electrical soil properties and measured physical soil properties.

3.2.8 *Soil Model linear correlation function, n*—one of the two mathematical expressions that are derived from performing linear regressions on two sets of soil test data; measured physical soil characteristics, and a corresponding set of electrical measurements made on the soil samples.

3.2.9 *soil resistance, n*—the value of the resistor in an equivalent parallel resistor-capacitor circuit that results from the probe-to-probe RF voltage, soil current, and resulting phase relationship due to the application of a RF source applied to the probes.

## 4. Summary of the Test Method

4.1 The test method is a two-step process.

4.1.1 A Soil Model that relates impedance measurement to the density and water content of the soil is developed. In this step the electrical measurements are collected at locations that have various water contents and densities typical of the range to be expected. Concurrent with collecting the electrical data, determination of density and water content are performed at the same locations using one or more of the traditional test methods, such as Test Methods **D1556** and **D2216**. The process is repeated over the site such that a range of water contents and densities are obtained. The combined data (impedance and density/water content) will generate the correlating linear regression functions of the Soil Model.

4.1.2 Once the Soil Model has been developed the CIMI device is used to make electrical measurements of the soil at locations of unknown density and water content. Using the Soil Model linear correlation functions, the procedure then estimates the values of soil density and water content based on the measured electrical properties.

<sup>3</sup> Institute of Electrical and Electronics Engineers Standards 100, 1972

<sup>4</sup> Sears & Zemansky, *University Physics*, 10th Edition

## 5. Significance and Use

5.1 CIMI measurements as described in this Standard Test Method are applicable to measurements of compacted soils intended for roads and foundations.

5.2 The test method is used for estimating in-place values of density and water content of soils and soil-aggregates based on electrical measurements.

5.3 The test method may be used for quality control and acceptance testing of compacted soil and soil aggregate mixtures as used in construction and also for research and development. The minimal disturbance nature of the methodology allows repetitive measurements in a single test location and statistical analysis of the results.

### 5.4 Limitations:

5.4.1 This test method provides an overview of the CIMI measurement procedure using a controlling console connected to a soil sensor unit which applies a 3.0 MHz RF voltage to an in-place soil via metallic probes that are driven into the soil at a prescribed distance apart. This test method does not discuss the details of the CIMI electronics, computer, or software that utilize on-board algorithms for estimating the soil density and water content

5.4.2 It is difficult to address an infinite variety of soils in this standard. However, data presented in X3.1 provides a list of soil types that are applicable for the CIMI use.

5.4.3 The procedures used to specify how data are collected, recorded, or calculated in this standard are regarded as the industry standard. In addition, they are representative of the significant digits that generally should be retained. The procedures prescribed in this standard do not consider material variation, purpose for obtaining the data, special purpose studies, or any considerations for the user's objectives; it is common practice to increase or reduce significant digits of reported data to be commensurate with these considerations. It is beyond the scope of this standard to consider significant digits used in analytical methods for engineering design.

NOTE 1—Notwithstanding the statements on precision and bias contained in this test method, the precision of this test method is dependent on the competence of the personnel performing it and the suitability of the equipment and facilities used. Agencies that meet the criteria of Practice D3740 are generally considered capable of competent and objective testing. Users of this test method are cautioned that compliance with Practice D3740 does not in itself ensure reliable results. Reliable testing depends on many factors; Practice D3740 provides a means of evaluating some of those factors.

5.5 All observed and calculated values shall conform to the guidelines for significant digits and rounding established in Practice D6026, unless superseded by this test method.

## 6. Interferences

6.1 Anomalies in the test material with electrical impedance properties significantly different from construction soils and aggregate evaluated during Soil Model development, such as metal objects or organic material, may affect the accuracy of the test method.

6.2 The accuracy of the results obtained by this test method may be influenced by poor contact between the soil electrical

probes and the soil being tested. Large air voids, relative to the volume of material being tested, that may be present between soil probes and the surface of the material being tested may cause incorrect density measurements. The shape of the soil electrical probe is important to the quality of the electrical measurements collected by the CIMI.

6.3 When driving the measuring electrical probes, it is critical to the accuracy of the measurement that they make a complete and tight contact with the soil over the entire conical part of the probe.

6.4 If the volume of soil material being tested as defined in X2.10 has oversize particles or large voids in the electrical field, this may cause errors in measurements of electrical properties. Where lack of uniformity in the soil due to layering, aggregate or voids is suspected, the test site shall be excavated and visually examined to determine if the test material is representative of the in-situ material in general and if an oversize correction is required in accordance with Practice D4718. Soils must be homogeneous and practically free of rocks that are in excess of five centimeters in diameter (2 in.) and construction debris for the most accurate results.

6.5 Statistical variance may increase for soil material that is significantly drier or wetter than optimum water content (2.5 % over optimum or 6.0 % below optimum) as determined using Test Methods D698 or D1557. Statistical variance may increase for soil material that is compacted to less than 88 % of the maximum dry density as determined using Test Methods D698 or D1557. The CIMI is generally more accurate when the Soil Model range is broader than the range of soil density and water content being tested in the field.

6.6 If temperature measurements are not used, an error may be introduced in the results depending on the value of the difference between the temperature of the soil used for the Soil Model and the unknown in-place soil being measured. All electrical values are equilibrated to 15.5 °C (60 °F). The equilibration is necessary because the soil temperature affects the electrical signals that are measured. The operating temperature range where the CIMI has been used globally is for the CIMI is between 1.1 °C (34 °F) and 50 °C (122 °F).

6.7 This test method applies only to non-frozen soil. The electrical properties of soil change considerably as soil temperature approaches the freezing point of the entrained water.

6.8 The use of electrical probes with different length than those used to make the Soil Model will introduce an error in the interpretation of the data and the estimation of the density of water content of the tested soils.

6.9 The use of a Soil Model that was generated from a different soil than that selected for unknown in-place measurements will result in errors in the estimation of the density and water content of the tested soils.

6.10 Attempts to measure unknown in-place soils with a Soil Model that was generated from a limited range of wet density or water content values, or both, may result in density and water content estimation errors.

6.11 Variation in pore water salinity, soil chemistry, soil mineralogy or other anomalies that causes field-test electronic

measurements to be outside the soil model operational range will cause the CIMI to report a warning message. X2.1 contains additional information regarding variation in electrical measurements and CIMI management techniques.

## 7. Apparatus

7.1 *Complex-Impedance Measuring Instrument* (See Fig. 1)—While exact details of construction of the apparatus and the electric circuits therein may vary, the system shall consist of the following:

7.1.1 *Soil Sensor Unit*—The “Soil Sensor” is a component of the CIMI which electronically combines the RF voltage source and the three RF measurement devices. Cables are used to connect the Soil Sensor to the electrical probes.

7.1.1.1 *RF Source*—Typically a 3 MHz RF voltage source is applied to the soil under test by probe type electrodes driven into the in-place soil at a prescribed depth and spacing. It measures the RF voltage applied to the soil electrical probes and RF current drawn by the soil. Additionally, the electrical phase relationship between the soil current and the probe-to-probe RF voltage is determined.

7.1.1.2 *Ammeter*—Means for measuring the RF soil current.

7.1.1.3 *Voltmeter*—Means for measuring the probe-to-probe RF voltage.

7.1.1.4 *Phase Difference Meter*—Means for measuring the phase difference between the probe-to-probe RF voltage and RF soil current.

7.1.1.5 *Connecting Cables*—For connecting the soil electrical probes to the display console meter (that is, ammeter, voltmeter, and phase difference meter).

7.1.2 *Display Console Unit*

7.2 *Soil Electrical Probes (Four Required, Equally Dimensioned)*—Of electrical conducting material suitable for driving into compacted material, typically constructed of common water hardened drill steel or stainless steel. The soil electrical probes have a conical shape designed to optimize the contact between the electrode and the compacted construction material around the electrode as it is driven in. To further control the contact area of the electrode with the compacted

construction material a shoulder is machined at the end of the conical taper that is undercut. When the conical electrode is driven in the compacted construction material to the level where the shoulder is level with the construction material surface, a repeatable surface area of the electrode is in contact with the construction material. The soil electrode achieves good contact with the compacted construction material and allows for consistency in electrical measurements.

7.2.1 The length of soil electrical probes can vary typically having embedment lengths between 102 mm (4 in.) and 31 mm (1.2 in.). The bottom diameter of each soil electrical probe is 5 mm (0.2 in.). The top diameter of the embedded length of each soil electrical probe varies between 14 mm (0.56 in.) for the 102 mm (4 in.) embedded length probe and 32 mm (1.25 in.) for the 305 mm (12 in.) embedded length probe. During the testing procedure, the soil electrical probe length is selected to best match thickness of the compacted material. Since a portion of the probe must be above the surface to facilitate electrical clip connector, the desired embedment depth must be clearly indicated with a scribed mark or change in geometry. The drawing in Fig. 2 below shows the size and dimensions for the 152 mm (6 in.) electrical probe, the other electrical probes have similar shape and can be reviewed in the manufacturer’s catalog.

7.3 A *template* shall be used to place the electrodes as they are driven into the soil. The four probes are driven into the soil at the 0°, 90°, 180°, and 270° in clockwise positions around the periphery of the template.

7.4 *Thermistor* temperature probe that connects to the CIMI for soil temperature measurement, and resulting compensation of calculated electrical soil parameters.

7.5 *Hand Tools*—Hand tools for driving and retrieving the soil electrical probes. A 2.7-kg to 5.4-kg (6-lb to 12-lb) dead blow or brass-faced hammer is used to avoid damaging the steel probes. The soil electrical probes are removed from the soil that has been tested using 30.5 cm (12 in.) channel lock pliers.

7.6 Other components of the system are:

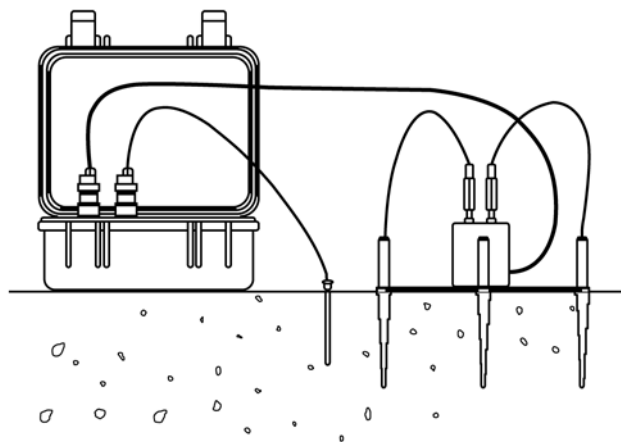

NOTE 1—The wires crossing in the diagram are not touching each other during use to prevent parasitic capacitance.

In the drawing the small probe is the thermistor and the three large probes are three of the four used to collect soil electrical data, the fourth probe is not seen in the section drawing because it is directly behind the center probe.

FIG. 1 Diagram of a Complex Impedance Measuring Instrument in Use

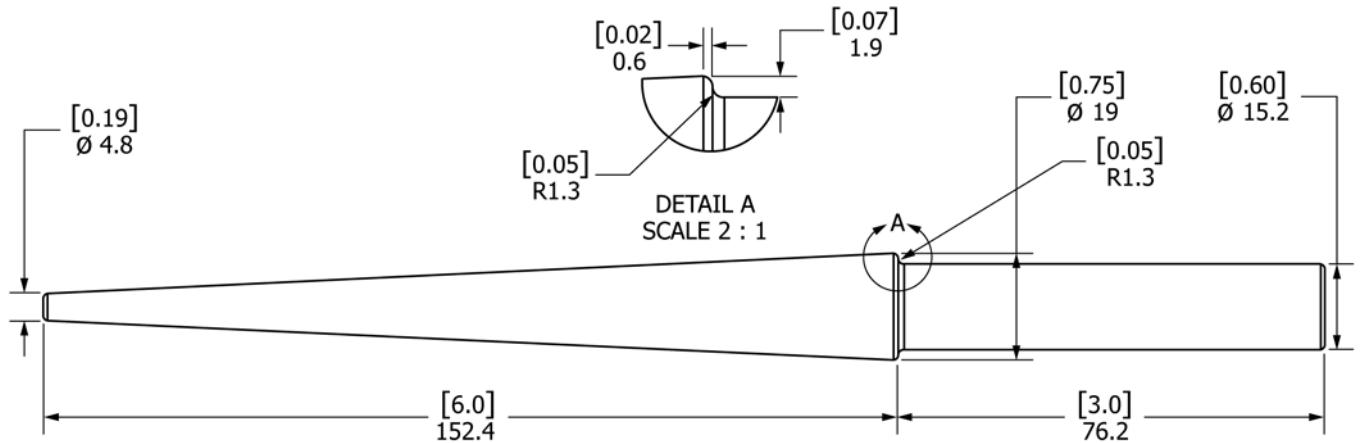

United States Patent Number 7,239,154, July 3, 2007

Dimensions in mm [in]  
 Tolerance:  $\pm 0.1$  mm [ $\pm 0.004$  in]  
 Material: 0.75 Grade W-1, water-hard. drill rod  
 Chamfer as shown: 45 deg., approx. 0.6 mm [0.024 in] on flat (3 places)

FIG. 2 Drawing of a 152.4 mm (6 in.) Soil Electrical Probe

- 7.6.1 Safety goggles, and
- 7.6.2 Software with which to download and process the data.

## 8. Calibration and Standardization

8.1 For a soil type that has not yet been modeled, a Soil Model must be generated. Refer to Section 9 for details on how the testing is performed.

8.2 Determine the test method(s) that will be used in conjunction with developing the Soil Model through calibration. For example, one or more of the test methods cited in 2.1. Assemble the equipment required for each test method.

8.3 Obtain a representative sample of soil from the site where in-place testing is conducted or from the borrow area planned as a source of material. The sample shall be of sufficient amount of soil for at least five compaction specimens, typically about 20 kg (44 lb). More material may be required if ancillary testing is planned, such as Atterberg limits, particle size analysis, etc.

8.4 Determine the laboratory compaction characteristics of the material to be tested. Test Methods D698 or D1557 for fine grained soils and soil rock mixtures that exhibit a clear maximum dry density or Test Methods D4253 or D7382 for predominately granular material.

8.5 Determine the depth of investigation required for the job and select the electrical probes with length equal to the depth of investigation. These same length probes must be used for both creating the Soil Model and for testing at the Job Site.

8.6 Select areas on the Job Site where the type of soil is consistent from place to place, and where there are differences in water content and compaction. Special preparation of spots

of different densities or water contents should be done the day before, so as to allow stabilization of the soil water content.

8.7 A matrix of six (6) spots should be used during the calibration procedure, consisting of two different soil density conditions and three (3) water content conditions that cover the range that is expected to be measured. The three calibration tests that evaluate high density soil will use test locations that ideally will have soil conditions that are close to the maximum density as determined by Test Methods D1557 or an equivalent method. The range in water content shall include low water content, middle range water content, and high water content that is near the optimum water content as determined by Test Methods D1557 and D2216 or equivalent test methods.

8.7.1 A four spot Soil Model matrix will result in the development of a Soil Model with an accuracy that will typically be less than the six-spot matrixes, and a nine-spot soil matrix will only slightly increase the accuracy of the Soil Model over that of the six-spot Soil Model matrixes. The four-spot Soil Model matrixes shall have variation of two density conditions and two water content conditions, wherein the high density and high water content shall be performed in soil that is near the maximum density and optimum water content as determined by Test Methods D1557 or an equivalent test method. The nine-spot Soil Model shall have variation of three density conditions and three water contents, wherein the high density-high water content shall be performed in soil that is near the maximum density and optimum water content as determined by Test Methods D1557 or an equivalent test method.

8.8 Be sure the spot does not contain large rocks or construction debris, and level the surface before testing.

8.9 Drive a large nail or small screwdriver into the soil near the test spot and insert the temperature probe at least 8 cm (3 in.).

8.10 Perform electrical tests with the CIMI on the selected Soil Model spots as prescribed in 9.4 – 9.7. Determine in-place wet density with physical means, such as Test Methods **D1556**, or an equivalent test method. Remove soil samples from the spot tested and perform an oven-dry moisture test as specified in Test Method **D4643**, Test Method **D4944**, or an equivalent test, to determine the water content.

8.11 Enter these physical data into the CIMI Console to associate them with the earlier electrical readings. The console will have the capability to perform an error analysis on the resulting Soil Model.

## 9. Procedure

9.1 Before testing a Job Site, the Soil Model for the soil type to be tested must be associated with that site, using the appropriate menu on the console display.

9.2 Prepare the test spots by leveling the surface, and checking for foreign debris, such as metal scraps or asphalt.

9.3 Drive a large nail or small screwdriver into the soil near the test spot and insert the temperature probe at least half the length of the probe into the ground.

9.4 Using the template, drive the 4 electrical probes into the spot so they are solid in place and driven to the proper depth. Soil probes must enter the soil as perpendicular to the soil surface as possible and not more than 20° from perpendicular to the surface of the soil under test. The soil probes shall be driven to the full depth of the conical section of each probe. If rocks are encountered during the process of driving the probes into the ground that result in refusal or deviation of greater than 20°, then the operator shall abandon the test site and move to another location that is close by.

9.5 Place the Soil Sensor (pins up) in the center of the template and connect the cables to two of the probes that are diametrically opposite. The cables must be away from each other and run straight to the probes. If a probe is loosened when attaching the cable, tap it with the hammer to seat it solidly.

9.6 Turn on the Console and create or select the Job Site to be tested.

9.7 Perform the test in accordance with the CIMI instruction manual for the collection of the electrical data with the four electrical probes as outlined in the procedural instructions for the CIMI. The test will include measurement from both sets of electrical probes, wherein a set of the probes are across from each other.

9.8 The CIMI Console uses the material unique correlation that was developed in the Soil Model process between the material's physical properties and the electrically measured soil properties. During a field test procedure, the CIMI is used to measure the electrical material properties and then calculates the dry density, water content, and percent compaction. Then, the physical properties are automatically displayed.

9.9 Observe and record dry density, water content, and percent compaction.

9.10 Record latitude and longitude of the testing site, if required.

9.11 Download to the data analysis software as required.

## 10. Calculation or Interpretation of Results

10.1 Using the electrical measurements made at the Soil Model test spots, the electrical **impedance** is computed by the quotient of the value of the RF voltage applied to the soil, and the resulting RF current through the soil.

$$Z = \frac{V}{I} \quad (1)$$

where:

$Z$  = Impedance,

$V$  = RF Voltage, and

$I$  = RF Current.

10.2 The **impedance** and the current over the resistance (C/R) ratio are both temperature compensated using an empirically determined procedure. The data presented in **Appendix X3. COMPLEX IMPEDANCE MEASURING INSTRUMENT TEST DATA** shows the CIMI performance over a broad range of soil types with temperature variations between 6.1 °C (43 °F) and 43.3 °C (110 °F). The electrical data was adjusted using the CIMI empirically determined temperature compensation procedure and the reported physical results for the material density and water content include the temperature compensation. The CIMI data from the 230 tests within nine soil types was compared to the nuclear density gauge. The histograms of the data for both material density and water content is presented in APPENDIX 3. The data summary information in APPENDIX 3 is from the Committee D18 on Soil and Rock Subcommittee on Surface and Subsurface Characterization, Research Report D18-1019, February 1, 2011.

10.3 A Linear Regression Analysis is performed with the physically determined wet density obtained in the Soil Model process, and the calculated and temperature-compensated **impedance**. **Fig. 3** shows a graphical representation of the linear regression that relates the soil impedance to the estimated soil wet density.

10.4 A parallel-circuit combination of a resistor (**R**) and capacitor (**C**) can be used to express the equivalent electrical characteristics of soil. These values are calculated by solving simultaneous electrical equations using RF voltage, RF current, and RF phase.

10.5 A Linear Regression Analysis is performed using the physically determined water mass per unit volume obtained in the Soil Model Process, and the temperature compensated ratio **C/R**. **Fig. 4** shows a graphical representation of the linear regression that relates the ratio of the capacitance over the resistance to the calculated water content.

10.6 When testing an unknown in-place soil type, the electrical measurements are used first to calculate impedance,

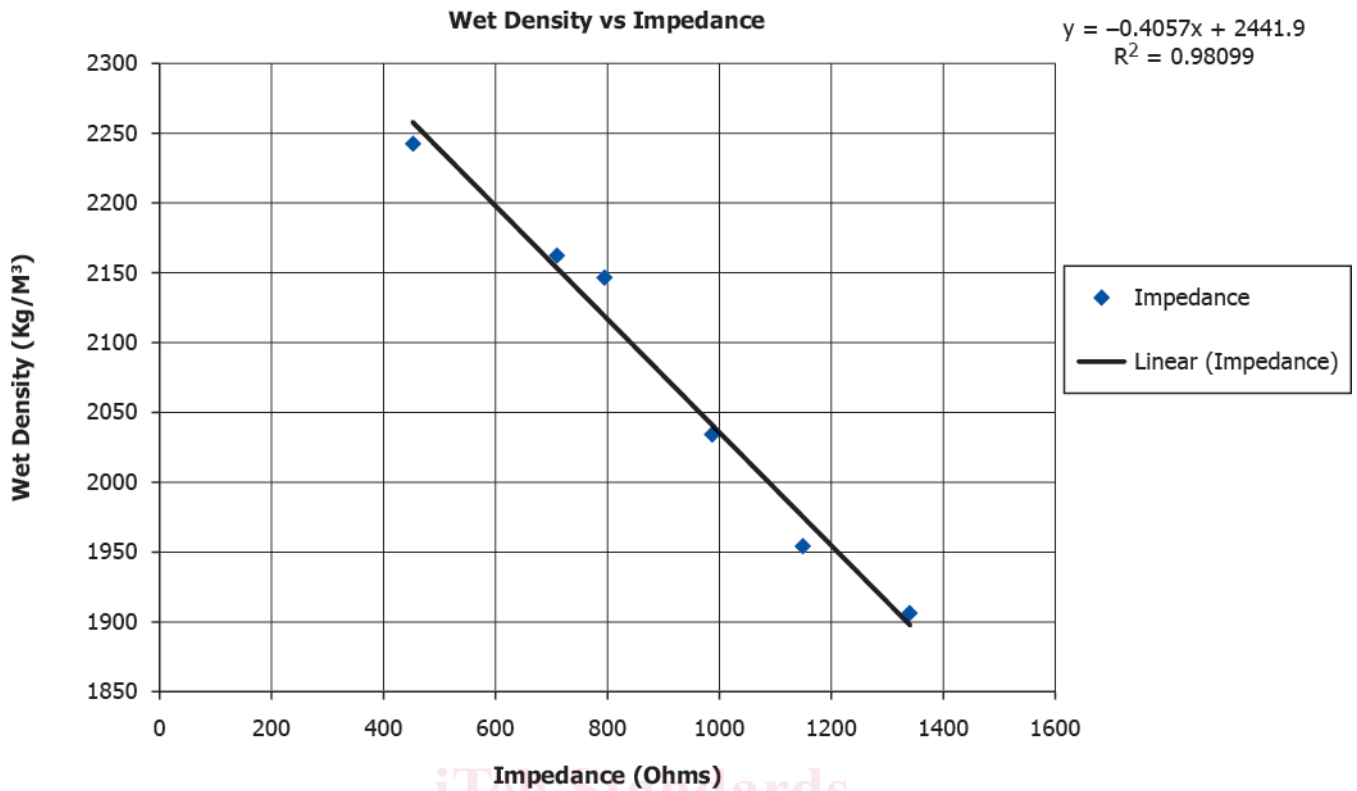

FIG. 3 Typical Values of Wet Density Vs. Impedance (Regression Equation Upper Right)  
The data points are electrical measured values (X axis) that are used to derive the Wet Density (Y axis).

then to calculate **C/R** as was done in the Soil Model procedure. These factors are then temperature compensated.

10.7 The wet density is calculated using the temperature-compensated impedance of the unknown in-place soil using the appropriate regression equation that was determined in the Soil Model process.

10.8 The water mass per unit volume in  $\text{kg/m}^3$  [ $\text{lb/ft}^3$ ] in the unknown in-place soil is also calculated with the temperature compensated **C/R**, using the appropriate regression equation developed in the Soil Model.

10.9 The dry density of the unknown in-place soil is determined by taking the difference of the wet density and the water mass per unit volume as determined from the Soil Model regression equations.

$$\rho_{dry} = \frac{\rho_{wet}}{1 + \frac{w}{100}} \quad (2)$$

where:

- $\rho_{dry}$  = dry density,
- $\rho_{wet}$  = wet density, and
- $w$  = water content in %.

10.10 The water content is calculated by obtaining the quotient of the water mass per unit volume and the dry density, expressed as a percentage.

$$w = 100 \frac{\text{water mass per unit volume}}{\rho_{dry}} \quad (3)$$

10.11 The percent compaction is calculated by obtaining the quotient of the measured dry density and the maximum dry density, expressed as a percentage as determined by Test Methods **D698** or **D1557**.

$$\% \text{ compaction} = 100 \frac{\rho_{dry}}{\text{max } \rho_{dry}} \quad (4)$$

where:

*% compaction* = soil relative compaction as related to the maximum dry density of the soil as determined by Test Methods **D698** or **D1557**.

### 11. Report: Test Data Sheet(s), Form(s), and Final Report(s)

11.1 The methodology used to specify how data are recorded on the test data sheet(s)/form(s), as given below, is covered in **1.2.1** and in Practice **D6026**.

11.2 The Field Data Records shall include, as a minimum, the following:

- 11.2.1 Test Number or Test Identification.
- 11.2.2 Location of test (for example, Station number or Coordinates or other identifiable information).
- 11.2.3 Visual description of material tested.
- 11.2.4 Lift number or elevation or depth.
- 11.2.5 Name of the operator(s).
- 11.2.6 Make, model and serial number of the test gauge.
- 11.2.7 Soil Model used.
- 11.2.8 Length of electrical probes used during testing.