



Designation: ~~F320~~—~~16~~ F320 – 21

# Standard Test Method for Hail Impact Resistance of Aerospace Transparent Enclosures<sup>1</sup>

This standard is issued under the fixed designation F320; the number immediately following the designation indicates the year of original adoption or, in the case of revision, the year of last revision. A number in parentheses indicates the year of last reapproval. A superscript epsilon ( $\epsilon$ ) indicates an editorial change since the last revision or reapproval.

*This standard has been approved for use by agencies of the U.S. Department of Defense.*

## 1. Scope

1.1 This test method covers the determination of the impact resistance of an aerospace transparent ~~enclosure, enclosure~~ (windshield, canopy, window, lens cover, etc.), hereinafter called windshield, during hailstorm conditions using simulated hailstones consisting of ice balls molded under tightly controlled conditions. This test shall also be used to meet hail test or performance requirements that are specified by design or contract.

1.2 ~~Units~~—The values stated in inch-pound units are to be regarded as standard. The values given in parentheses are mathematical conversions to SI units that are provided for information only and are not considered standard.

1.3 *This standard does not purport to address all of the safety concerns, if any, associated with its use. It is the responsibility of the user of this standard to establish appropriate ~~safety~~ safety, health, and ~~health~~ environmental practices and determine the applicability of regulatory limitations prior to use.* For specific hazard statements, see Section 7.

1.4 *This international standard was developed in accordance with internationally recognized principles on standardization established in the Decision on Principles for the Development of International Standards, Guides and Recommendations issued by the World Trade Organization Technical Barriers to Trade (TBT) Committee.*

## 2. Terminology

### 2.1 Definitions:

2.1.1 *damage, n*—any modification in visual properties or integrity of a windshield as a result of hail impact including scratches, crazing, delamination, cracks, penetration, or shattering.

2.1.2 *ice ball, n*—a frozen masssphere of water, with filler, that simulates a natural hailstone in weight, size, and toughness.

2.1.3 *impact angle, n*—the angle between the ice ball flight path and the target normal.

2.1.4 *sabot, n*—a plastic ~~device for protecting carrier~~ used to carry the ice ball ~~while in~~ down the launch tube. One type of sabot (see Fig. 1) consists of a split polycarbonate rod containing a central cavity for holding the ice ball. Each sabot half is designed to assure aerodynamic separation from the ice ball after ejection exiting from the launch tube.

<sup>1</sup> This test method is under the jurisdiction of ASTM Committee F07 on Aerospace and Aircraft and is the direct responsibility of Subcommittee F07.08 on Transparent Enclosures and Materials.

Current edition approved April 1, 2016 May 1, 2021. Published April 2016 June 2021. Originally approved in 1978. Last previous edition approved in 2014 2016 as F320—10: F320 – 16. DOI: 10.1520/F0320-16; 10.1520/F0320-21.

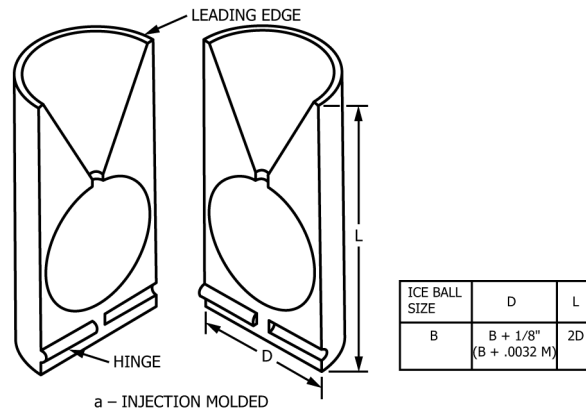

a - INJECTION MOLDED

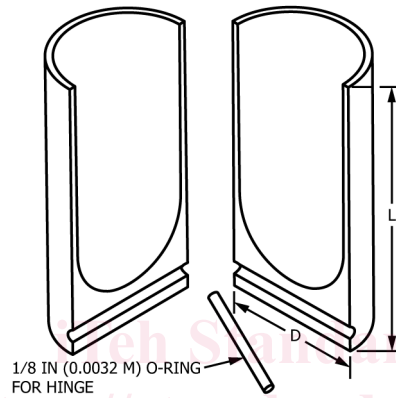

b - MACHINED  
**FIG. 1 Sabot Configuration**

### 3. Summary of Test Method

3.1 The test method involves launching a series of ice balls of specified sizes at a sample windshield at a designated velocity and angle and in a specified pattern. Requirements are specified for the ice ball, test specimen, procedure, and data acquisition. The ice ball is photographed in flight to verify its integrity.

3.2 Requirements are specified for a particular apparatus and test procedure, but options are permitted for certain areas. However, it must be possible to demonstrate that the options used result in an ice ball impacting the test panel with the same size, consistency, and velocity as with the specified apparatus and procedure. Following are areas where options are allowed:

3.2.1 *Ice Ball Mold Material.*

3.2.2 *Launcher*—Any type of launcher is allowable as long as the ice ball reaches the test specimen intact at the correct speed. The use of sabots and sabot material and geometry are optional.

3.2.3 *Method of Determining Ice Ball Integrity.*

3.2.4 *Ice Ball Speed Measurement*, optional—as long as accuracy standards are met.

3.2.5 *Test Specimen Sizes*—Those given are minimum.

3.2.6 *Safety*—Safety must satisfy the safety standards of the test facility being used.

### 4. Significance and Use

4.1 This test method shall be used to determine the hail impact resistance of windshields for acceptance, design, service, or

research purposes. By ~~coupling~~ using this method with the installed windshield angle and velocity of a specific aerospace vehicle, design allowables, criteria, and tolerances can be established for that vehicle's windshield.

**5. Apparatus**

5.1 The facilities and equipment required for the performance of this test procedure include a suitable firing range equipped with an ice ball mold, a launcher, blast deflector, sabot trap, velocity measuring system, test specimen holder, and a camera with or without strobe lights to verify ice ball integrity. Ancillary equipment required for this test ~~include~~ includes test specimen, ice balls, sabots, and firing cartridges. An example facility is described below.

5.2 *Firing Range*—The firing range shall be a minimum of 9 by 18 ft (3 by 6 m) enclosed to contain flying debris and to exclude unauthorized personnel.

5.3 *Ice Ball Mold*, two aluminum blocks with hemispherical cavities and vent holes for filling with water and for water expansion during freezing.

5.4 *Launcher*, a variety of launchers are suitable as noted in 3.2.23.2.2. In addition to the powder gun described in this test method, laboratories have also successfully utilized ~~compressed gas~~ compressed-gas gun launchers. An example of a powder gun launcher is shown in Fig. 2, consisting of a barrel, breech, breech plug, and control. The barrel shall be made from high-quality AISI 4130 seamless steel tubing, or equivalent, in the annealed condition. The breech shall be made from AISI 4130 steel rod, or equivalent, heat treated to a ~~160-160 to 180-ksi~~ 1104-180 ksi (1104 to 1242 MPa) ultimate tensile strength condition. The size of cavity to be used in the breech depends on the desired test velocity (see Table 1). The breech plug, which locks the cartridge in place and contains the firing pin, shall be made of 4340 steel heat treated to a ~~160-160 to 180-ksi~~ 180 ksi ultimate tensile strength condition. The firing pin is actuated by a kinetic impact air piston. Control is accomplished by an electrically actuated air valve. For a ~~100-psi~~ (0.69 MPa) 100 psi (0.69 MPa) air source, a 0.75-in. 0.75 in.<sup>2</sup> (4.84 cm<sup>2</sup>) piston traveling 0.5 in. (13 mm) is used.

5.5 *Blast Deflector*—Place a plate with a ~~4-in.~~ (100-mm) 4 in. (100 mm) diameter hole as shown in Fig. 3 between the sabot trap and the first velocity measuring station. Then place a corrugated cardboard plate over the hole. This deflector is not required for ~~compressed gas~~ compressed-gas gun systems.

5.6 *Sabot Trap* is made by placing two steel plates two to four ice ball diameters apart, centered on the flight path and located

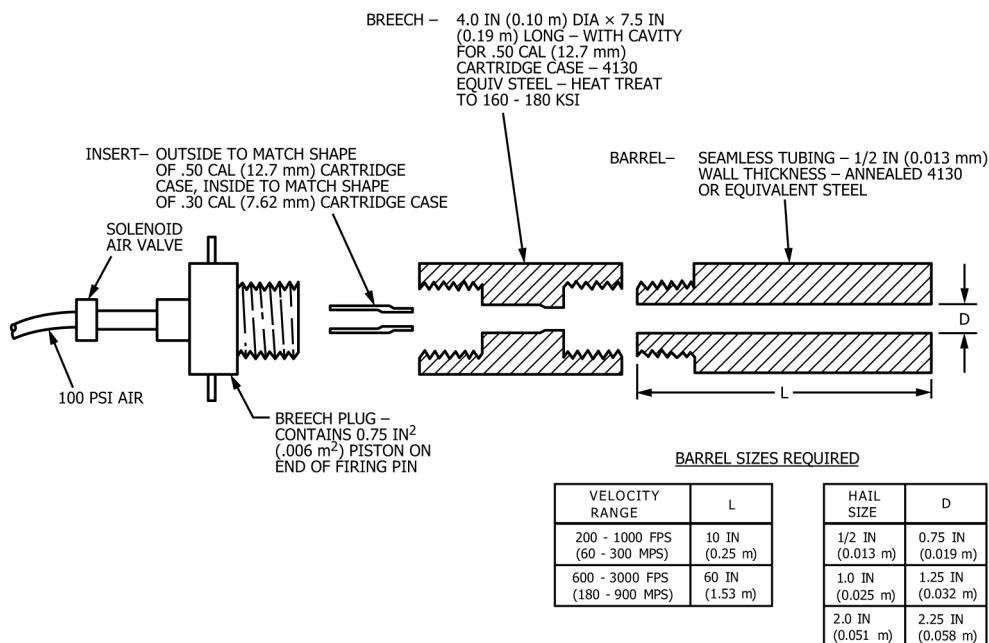

FIG. 2 Launcher Design

TABLE 1 Power Powder Loads

Desired Velocity, ft/s (m/s)	Barrel Bore, in. (mm)	Barrel Length, in. (m)	Cartridge Size, caliber	Powder Type	Powder Weight, grains (g)
200 (60)	1.25 (32)	10 (0.25)	0.30	Bullseye <sup>A</sup>	6 (0.39)
	2.25 (57)	10 (0.25)	0.30	Bullseye	6 (0.39)
500 (150)	0.75 (19)	10 (0.25)	0.30	Bullseye	5 (0.32)
	1.25 (32)	60 (1.52)	0.50	IMR 4227 <sup>B</sup>	40 (2.59)
	2.25 (57)	60 (1.52)	0.50	Bullseye	30 (1.94)
	2.25 (57)	10 (0.25)	0.30	Bullseye	12 (0.78)
1000 (300)	0.75 (19)	10 (0.25)	0.30	Bullseye	9 (0.58)
	1.25 (32)	60 (1.52)	0.50	Bullseye	60 (3.89)
	1.25 (32)	10 (0.25)	0.30	Bullseye	20 (1.30)
	2.25 (57)	60 (1.52)	0.50	Bullseye	70 (4.54)
2000 (600)	0.75 (19)	60 (1.52)	0.50	Bullseye	35 (2.27)
	1.25 (32)	60 (1.52)	0.50	Bullseye	70 (4.54)
	2.25 (57)	60 (1.52)	0.50	Bullseye	150 (9.72)
	2.25 (57)	60 (1.52)	0.50	Bullseye	150 (9.72)

<sup>A</sup> The sole source of supply of the apparatus manufacturer known to the committee at this time is Hercules, Inc., 1313 North Market Street Wilmington, DE 19894-0001. If you are aware of alternative suppliers, please provide this information to ASTM International Headquarters. Your comments will receive careful consideration at a meeting of the responsible technical committee<sup>2</sup>, which you may attend.

<sup>B</sup> The sole source of supply of the apparatus manufacturer known to the committee at this time is duPont, Chestnut Run Plaza 705/GS38 Wilmington, DE 19880-0705. If you are aware of alternative suppliers, please provide this information to ASTM International Headquarters. Your comments will receive careful consideration at a meeting of the responsible technical committee<sup>2</sup>, which you may attend.

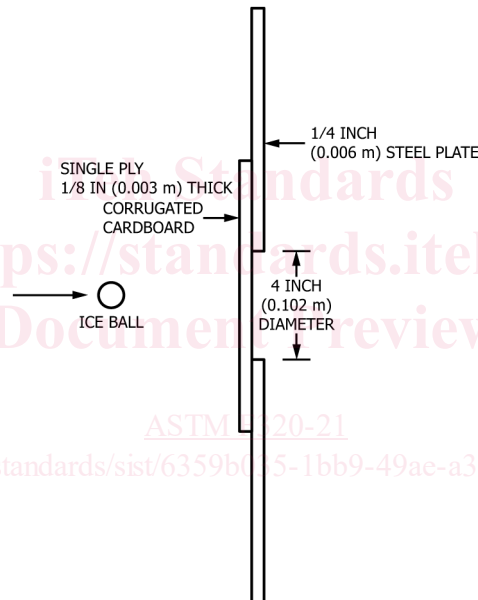

FIG. 3 Blast Deflector

a minimum of 6 ft (1.82 m) from the launcher muzzle as shown in Fig. 4. This trap is not required for systems that utilize aerodynamic separation of the sabot or other suitable mechanisms to ensure that the sabot does not impact the test article.

5.7 Velocity Measurement System—The break-screen velocity measurement—There are multiple options for velocity measurement including laser-photodetector systems, light-screens, high-speed photogrammetry, chronographs, and break screens. The essential

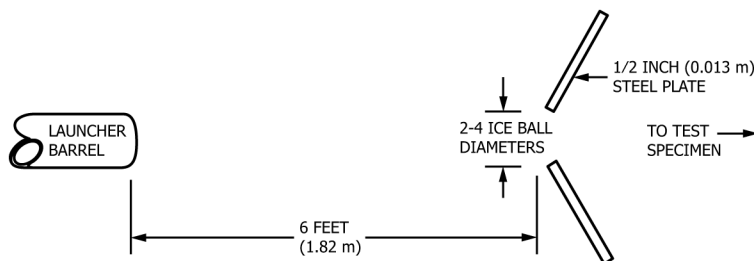

FIG. 4 Sabot Trap

features of the velocity measurement system are that it be accurate and repeatable, not be triggered by small stray objects traveling with the projectile, and not alter the flight path or damage the projectile. The system shall be accurate to  $\pm 1\%$  or better. Historically, the break-screen has been used and is described below. The break-screen velocity measurement method consists of a set of screens, power supply, wiring, and counters. Three screens shall be made from a lightweight bond paper with an electrical circuit painted on the paper by the silk screen process. The paint for the circuit shall be electronic grade electrical conducting paint.<sup>2</sup> Do not thin the paint. The break-screen shall be made with lines  $\frac{1}{8}$  in. (3.2 mm) wide by 18 in. (460 mm) long as shown in Fig. 5 giving a resistance of no more than 300  $\Omega$ . Fig. 6 shows the arrangement of components and gives the electronic circuit to be used with the three screens. The system shall be accurate to  $\pm 1\%$  or better. Laser-based photo detector systems and high-speed-film-based systems are also acceptable, provided the accuracy is  $\pm 1\%$ .

5.8 *Test Specimen Holder*—Use one of two types of test specimen holders. The one—The test specimen holder shall be designed to securely grip the perimeter of the panel with the impacted zone being unsupported. The test specimen holder shown in Fig. 7 is designed to hold an 18-18 by 18-in. (0.46-18 in. (0.46 by 0.46-m)0.46 m) test specimen that can be impacted at angles ranging from 0 to 80° as detailed in Section 8. When testing a complete windshield, use edge restraints similar to the actual installation and place the windshield in the proper orientation (see 9.2).

5.9 *Ice Ball Integrity Camera*—Verify ice ball integrity before impact by obtaining a photograph or high-speed video of the ice ball in flight before impact. This is accomplished—Still images are captured by illuminating the ice ball with a strobe light while the ice ball is in the field of view of a camera lens. This synchronization can be obtained by using an open shutter with the strobe triggered at the second—with a velocity screen. The signal is split with part going to the velocity counters and part to a variable time-delay generator. Using the estimated ice ball velocity, a time delay is selected so the ice ball will be in view of the camera lens when the strobe is triggered.

5.10 *Balance*, for powdergunpowder and ice balls, capacity 0.2 lb (100 g), accuracy  $\pm 1\%$  (1.0 g);  $\pm 1\%$ .

5.11 *Clinometer or Protractor*, to measure impact angle, accuracy  $\pm \frac{1}{4}^\circ$ .

5.12 *Syringe*, 100-cm<sup>3</sup> 100 cm<sup>3</sup>, for puttinginjecting water into the ice ball mold.

## 6. Materials

6.1 *Sabot*—An effective injection molded sabot configuration is shown in Fig. 1a, while a machined configuration is shown in Fig. 1b. In either design, polycarbonate material is used to form the two halves of the sabot at a minimum diameter equal to the ice ball diameter plus  $\frac{1}{8}$  in. (3.2 mm) with a length approximately twice this diameter to assure in-flight separation of the sabot halves. An acceptable tolerance of the sabot diameter has been found to be within 0.005 in. (0.127 mm) of the minimum barrel diameter.

6.2 *Gunpowder*—The brands listed in Table 1 have been found to be satisfactory for powder guns.

6.3 *Cartridge Cases*, with primers, 0.30 and 0.50 caliber, or other sizes used with powder guns.

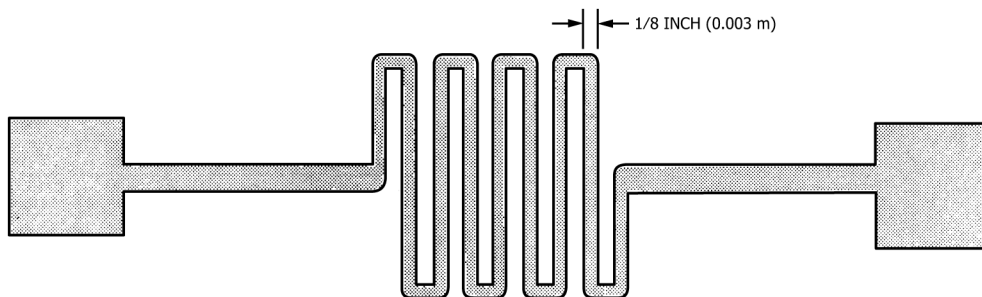
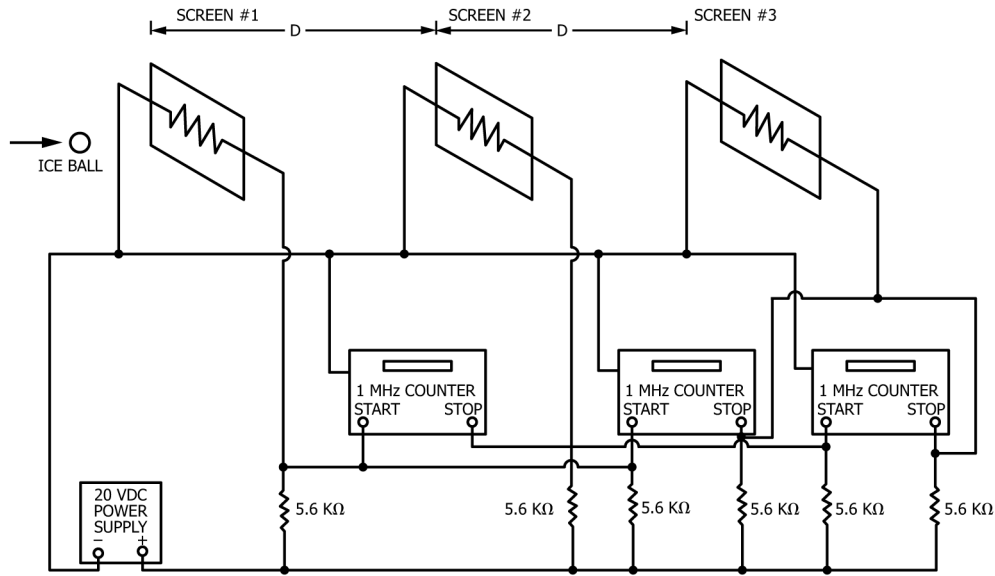

FIG. 5 Velocity Screen

<sup>2</sup> The sole source of supply of the apparatus known to the committee at this time is "Silver Preparation," duPont electronic grade No. 4817. If you are aware of alternative suppliers, please provide this information to ASTM International Headquarters. Your comments will receive careful consideration at a meeting of the responsible technical committee<sup>2</sup>, which you may attend.



$$v = \frac{D}{t_1} = \frac{2D}{t_2} = \frac{D}{t_3}$$

WHERE V = VELOCITY  
 D = SCREEN SEPARATION  
 t = TIME FROM COUNTER #1, #2, OR #3

FIG. 6 Velocity Measuring System

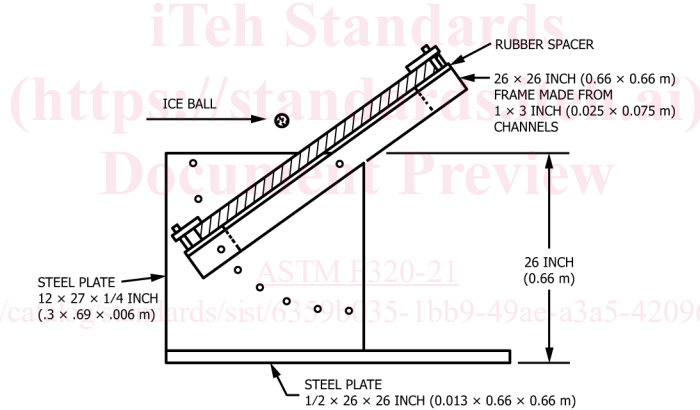

FIG. 7 Example Test Specimen Holder

6.4 Cotton Fiber—Standard pharmaceutical cotton balls.

6.5 Bags, Polyethylene, commercial grade.

6.6 Plastic Wrapping—Poly(vinylidene chloride).

7. Hazards

7.1 Powder Gunpowder Storage and Handling—Powder Gunpowder handling and storage shall conform to all ~~Federal~~federal and local regulations. The handling facility in which the powder charges are weighed and loaded must be reserved for this purpose alone. Procure primers already mounted in the cartridge cases or special facilities provided for this dangerous operation.

7.2 Firing Area—~~Exclude~~Clear all personnel from the firing area ~~except the operator~~during testing. The firing area shall have visual and audible warning devices to alert personnel that a test is in progress.

7.3 *Locked Switch*—There shall be a locked switch on the firing circuit which can be closed only by a key kept in the operator’s possession during the entire calibration and test procedure.

## 8. Test Specimen

8.1 The test specimen shall be a duplicate of the windshield being simulated or a section thereof. If a section is used, it shall measure 18 by 18 in. (0.46 by 0.46 m). Surface condition shall be dry. Temperature shall be ambient unless special temperatures are associated with the particular installation being simulated. In the case of special temperatures, the temperature to use and the method of attainment are to be established by mutual agreement between the user and the testing agency. Use a strong backlight to aid visual inspection of the windshield both before and after the test.

## 9. Preparation of Apparatus

9.1 *Velocity*—Select the ice ball velocities from one of the standard values in **Table 2** unless otherwise specified.

9.2 *Impact Angle*—Select the impact angles from the following standard conditions, unless otherwise specified.

9.2.1 For the ~~18-18~~ by ~~18-in.~~ (~~0.46-18 in.~~ (~~0.46~~ by ~~0.46-m~~)~~0.46 m~~) cut section, the impact angle shall be 45° at the center of the section.

9.2.2 For the complete windshield, the impact angle at the center and at the edge shall be the actual minimum angle between the ice ball flight path and the normal to the windshield surface.

9.2.3 For ground conditions (applicable to parked aircraft), the impact angle shall be normal to the test specimen surface.

9.3 *Preparation of Ice Balls:*

9.3.1 Separate and weigh an amount of cotton filler as specified in **10.2**.

9.3.2 Dip the above amount of cotton into a container of water, remove, and shape into a sphere.

9.3.3 Place the cotton sphere into the mold.

9.3.4 After securing the mold halves, fill the cavity with water ~~from~~using a syringe. Place the syringe point at the lowest point in the mold cavity so that the rising water will drive the air out.

9.3.5 Place the mold in a ~~0°F~~ (~~-18°C~~) 0 °F (-18 °C) environment until frozen. With experience, complete freezing can be determined from the length of the sprue extruded from the filler hole.

9.3.6 Rapidly bring the mold to above freezing by immersing it in room temperature water until the ice on the mold slips. Remove from water.

9.3.7 Open the mold and remove the ice ball. Seal the ice ball in a polyethylene bag and store in the freezer at ~~0°F~~ (~~-18°C~~) 0 °F (-18 °C). Ice balls shall not be more than four days old before use. Minimize the time out of the mold because of the formation of cracks with time.

**TABLE 2 Velocity**

Aircraft Type	Velocity, ft/s (m/s)
Ground (parked aircraft)	100 (30)
Low speed	200 (60)
Fixed wing, piston engine, or rotary wing, turbine engine	500 (150)
Fixed wing, turbine engine	1000 (300)
Supersonic	2000 (600)