



SLOVENSKI STANDARD

SIST EN 13693:2004

01-oktober-2004

Montažni betonski izdelki - Specialni strešni elementi

Precast concrete products - Special roof elements

Betonfertigeteile - Besondere Fertigeteile für Dächer

Produits préfabriqués en béton - Éléments spéciaux de toiture

Ta slovenski standard je istoveten z: **EN 13693:2004**

[SIST EN 13693:2004](https://standards.iteh.ai/catalog/standards/sist/59a581f2-24de-402a-8335-85ff41376ea9/sist-en-13693-2004)

<https://standards.iteh.ai/catalog/standards/sist/59a581f2-24de-402a-8335-85ff41376ea9/sist-en-13693-2004>

ICS:

91.060.20	Strehe	Roofs
91.100.30	Beton in betonski izdelki	Concrete and concrete products

SIST EN 13693:2004

en,fr,de

iTeh STANDARD PREVIEW
(standards.iteh.ai)

SIST EN 13693:2004

<https://standards.iteh.ai/catalog/standards/sist/59a581f2-24de-402a-8335-85ff41376ea9/sist-en-13693-2004>

ICS 91.100.30

English version

Precast concrete products - Special roof elements

Produits préfabriqués en béton - Éléments spéciaux de
couverture

Betonfertigteile - Besondere Fertigteile für Dächer

This European Standard was approved by CEN on 24 June 2004.

CEN members are bound to comply with the CEN/CENELEC Internal Regulations which stipulate the conditions for giving this European Standard the status of a national standard without any alteration. Up-to-date lists and bibliographical references concerning such national standards may be obtained on application to the Central Secretariat or to any CEN member.

This European Standard exists in three official versions (English, French, German). A version in any other language made by translation under the responsibility of a CEN member into its own language and notified to the Central Secretariat has the same status as the official versions.

CEN members are the national standards bodies of Austria, Belgium, Cyprus, Czech Republic, Denmark, Estonia, Finland, France, Germany, Greece, Hungary, Iceland, Ireland, Italy, Latvia, Lithuania, Luxembourg, Malta, Netherlands, Norway, Poland, Portugal, Slovakia, Slovenia, Spain, Sweden, Switzerland and United Kingdom.

STANDARD PREVIEW
(standards.iteh.ai)
SIST EN 13693:2004
<https://standards.iteh.ai/catalog/standards/sist/59a581f2-24de-402a-8335-85ff41376ea9/sist-en-13693-2004>



EUROPEAN COMMITTEE FOR STANDARDIZATION
COMITÉ EUROPÉEN DE NORMALISATION
EUROPÄISCHES KOMITEE FÜR NORMUNG

Management Centre: rue de Stassart, 36 B-1050 Brussels

Contents

The numbering of clauses is strictly related to EN 13369, *Common rules for precast concrete products*, at least for the first three digits. When a clause of EN 13369 is not relevant or included in a more general reference of this standard, its number is omitted and this may result in a gap on numbering

	page
Foreword.....	4
Introduction.....	6
1 Scope.....	7
2 Normative references.....	7
3 Terms and definitions.....	7
4 Requirements.....	7
4.1 Material requirements.....	7
4.2 Production requirements.....	8
4.2.1 Concrete production.....	8
4.2.2 Hardened concrete.....	8
4.2.3 Structural reinforcement.....	8
4.3 Finished product requirements.....	8
4.3.1 Geometrical properties.....	8
4.3.2 Surface characteristics.....	9
4.3.3 Mechanical resistance.....	10
4.3.4 Resistance and reaction to fire.....	10
4.3.5 Acoustic properties.....	10
4.3.6 Thermal properties.....	10
4.3.7 Durability.....	10
4.3.8 Other requirements.....	11
5 Test methods.....	11
5.1 Tests on concrete.....	11
5.2 Measuring of dimensions.....	11
5.3 Weight of the elements.....	12
5.4 Load test of elements.....	12
6 Evaluation of conformity.....	12
6.1 General.....	12
6.2 Type testing.....	12
6.3 Factory production control.....	12
7 Marking and labelling.....	13
8 Technical documentation.....	13
Annex A (informative) Terminology of plate elements.....	14
A.1 Shell element.....	14
A.2 Main flexural behaviour.....	15
Annex B (informative) Types of products.....	16
Annex C (informative) Mechanical behaviour.....	24
C.1 General.....	24
C.2 Types of structural behaviour.....	24
C.2.1 General.....	24
C.2.2 Beam-like behaviour.....	24
C.2.3 Hyperstatic plate-systems behaviour.....	25
C.2.4 Isostatic plate-system behaviour.....	26
C.2.5 Singular structural systems.....	26

C.2.6	Integrated structure-completion systems	26
C.3	Stability requirements	27
C.4	Supports and connections	28
Annex D	(informative) Serviceability and resistance verifications	29
D.1	Biaxial strength of concrete	29
D.2	Biaxial strength of shell element	30
D.2.1	General.....	30
D.2.2	Compressive strength of thin plates	30
D.2.3	Tensile strength of thin plates	30
D.2.4	Shear strength of thin plates	31
D.2.5	Flexural strength of thin plates	31
D.3	Global flexural strength of the cross section	32
Annex E	(informative) Flexural test of elements	33
E.1	General.....	33
E.2	Load test under service conditions - symmetrical loading.....	34
E.2.1	General.....	34
E.2.2	Settling cycle.....	34
E.2.3	First cycle	34
E.2.4	Second cycle.....	35
E.2.5	Interpretation of the results	35
E.3	Load test under service conditions - dissymmetrical loading.....	36
E.3.1	General.....	36
E.3.2	Third cycle.....	36
E.3.3	Fourth cycle	37
E.3.4	Interpretation of the results	37
E.4	Load test up to failure conditions.....	37
E.4.1	General.....	37
E.4.2	Final cycle	37
E.4.3	Interpretation of the results	38
Annex Y	(Informative) Choice of CE marking method.....	40
Y.1	General.....	40
Y.2	Method 1	40
Y.3	Method 2	40
Y.4	Method 3	40
Annex ZA	(informative) Clauses of this European Standard addressing essential requirements or other provisions of EU Directives.....	41
ZA.1	Scope and relevant characteristics	41
ZA.2	Procedure for attestation of conformity of precast prestressed concrete roof elements	42
ZA.2.1	System of attestation of conformity	42
ZA.2.2	EC Certificate and Declaration of conformity.....	43
ZA.3	CE marking and labelling.....	44
ZA.3.1	General.....	44
ZA.3.2	Declaration of geometrical data and material properties	45
ZA.3.3	Declaration of product properties.....	47
ZA.3.4	Declaration of compliance with a given design specification	50
Bibliography	52

Foreword

This document (EN 13693:2004) has been prepared by Technical Committee CEN/TC 229 "Precast concrete products", the secretariat of which is held by AFNOR.

This European Standard shall be given the status of a national standard, either by publication of an identical text or by endorsement, at the latest by March 2005, and conflicting national standards shall be withdrawn at the latest by June 2006.

This document has been prepared under a mandate given to CEN by the European Commission and the European Free Trade Association, and supports essential requirements of Construction Products Directive (89/106/EEC) of European Union (EU).

For relationship with EU Directive(s), see informative Annex ZA, which is an integral part of this document.

This standard is one of a series of product standards for precast concrete products.

For common aspects reference is made to *EN 13369: Common rules for precast products*, from which also the relevant requirements of the *EN 206-1: Concrete - Part 1: Specification, performances, production and conformity* are taken.

The references to EN 13369 by CEN/TC229 product standards are intended to make them homogeneous and to avoid repetitions of similar requirements. **(standards.iteh.ai)**

Eurocodes are taken as a common reference for design aspects. The installation of some structural precast concrete products is dealt with by *ENV 13670-1: Execution of concrete structures – Part 1: Common rules*, which has at the moment the status of an European prestandard. In all countries it can be accompanied by alternatives for national application and it shall not be treated as a European Standard.

The programme of standards for structural precast concrete products comprises the following standards, in some cases consisting of several parts:

- EN 1168, *Precast concrete products - Hollow core slabs*
- prEN 12794, *Precast concrete products - Foundation piles*
- EN 12843, *Precast concrete products - Masts and poles*
- EN 13224, *Precast concrete products - Ribbed floor elements*
- EN 13225, *Precast concrete products - Linear structural elements*
- EN 13693, *Precast concrete products - Special roof elements*
- prEN 13747, *Precast concrete products - Floor plates for floor systems*
- prEN 13978, *Precast concrete products - Precast concrete garages*
- prEN 14843, *Precast concrete products – Stairs*
- prEN 14844, *Precast concrete products - Box culverts*
- prEN 14991, *Precast concrete products - Foundation elements*
- prEN 14992, *Precast concrete products - Wall elements: Products properties and performances*

— prEN 15037, *Precast concrete products - Beams for beam-and-block floor systems*

This standard defines in Annex ZA the application methods of CE marking to products designed using the relevant EN Eurocodes (EN 1992-1-1 and EN 1992-1-2). Where, in default of applicability conditions of EN Eurocodes to the works of destination, design Provisions other than EN Eurocodes are used for mechanical strength and/or fire resistance, the conditions to affix CE marking to the product are described in ZA.3.4.

According to the CEN/CENELEC Internal Regulations, the national standards organizations of the following countries are bound to implement this European Standard: Austria, Belgium, Cyprus, Czech Republic, Denmark, Estonia, Finland, France, Germany, Greece, Hungary, Iceland, Ireland, Italy, Latvia, Lithuania, Luxembourg, Malta, Netherlands, Norway, Poland, Portugal, Slovakia, Slovenia, Spain, Sweden, Switzerland and United Kingdom.

iTeh STANDARD PREVIEW (standards.iteh.ai)

[SIST EN 13693:2004](#)

<https://standards.iteh.ai/catalog/standards/sist/59a581f2-24de-402a-8335-85ff41376ea9/sist-en-13693-2004>

Introduction

The evaluation of conformity given in this standard refers to the completed precast elements which are supplied to the market and covers all the production operations carried out in the factory.

For design rules and resistance to fire principal reference is made to EN 1992-1-1 and EN 1992-1-2. Additional complementary rules are provided where necessary.

In Clause 4.3.3 and 4.3.4 this document includes specific provisions resulting from the application of EN 1992-1-1 and EN 1992-1-2 rules to the concerned product. The use of these provisions is consistent with a design of works made with EN 1992-1-1 and EN 1992-1-2.

iTeh STANDARD PREVIEW (standards.iteh.ai)

[SIST EN 13693:2004](#)

<https://standards.iteh.ai/catalog/standards/sist/59a581f2-24de-402a-8335-85ff41376ea9/sist-en-13693-2004>

1 Scope

This document identifies the requirements, the basic performance criteria and the evaluation of conformity for special precast roof elements made of reinforced or prestressed normal weight concrete, used for the construction of buildings, with or without separating function with respect to fire resistance.

NOTE The title of special roof elements refers to thin-walled structural elements with deformable transverse profile, such as folded plates, or shell elements, the intended use being specific for roofings with their typical loads. This type of elements combines the overall flexural behaviour along the main span with a complex distribution of in-plane forces and local moments.

Other types of elements can be used in roofing, such as ribbed units, floor slabs, For these elements reference shall be made to their respective product standards.

Secondary structural components, possibly used in combination with the main roof elements, such as load bearing shuttering plates and shells, roof light frames, ..., shall refer to their respective product standard or technical approval.

This document covers terminology, performance criteria, tolerances, relevant physical properties, test methods, and aspects of transport and erection.

This document does not deal with seismic behaviour.

This document does not cover load bearing capacity determined by testing.

iTeh STANDARD PREVIEW (standards.iteh.ai)

2 Normative references

The following referenced documents are indispensable for the application of this document. For dated references, only the edition cited applies. For undated references, the latest edition of the referenced document (including any amendments) applies. <https://standards.iteh.ai/catalog/standards/sist/59a581f2-24de-402a-8335-85ff41376ea9/sist-en-13693-2004>

EN 1990:2002, *Eurocode: Basis of structural design*.

EN 1992-1-1:2004, *Eurocode 2: Design of concrete structures - Part 1-1: General rules and rules for buildings*.

EN 1992-1-2:2004, *Eurocode 2: Design of concrete structures - Part 1-2: General rules - Structural fire design*.

EN 13369:2004, *Common rules for precast concrete products*.

3 Terms and definitions

For the purposes of this document, the terms and definitions given in EN 13369:2004 and the following apply.

NOTE 1 See also Annex A.

NOTE 2 Annex B gives a review of common types of special precast prestressed concrete roof elements together with some related terminology.

4 Requirements

4.1 Material requirements

For general aspects, constituent materials of concrete, reinforcing and prestressing steel, inserts and connections, the relevant clauses of EN 13369:2004 4.1 shall apply. In particular the ultimate tensile and tensile yield strength of steel shall be considered.

4.2 Production requirements

4.2.1 Concrete production

Clause 4.2.1 of EN 13369:2004 shall apply. In particular the compressive strength of concrete shall be considered.

4.2.2 Hardened concrete

Clause 4.2.2 of EN 13369:2004 shall apply.

4.2.3 Structural reinforcement

In addition to Clause 4.2.3 of EN 13369:2004, the following specific rules shall apply.

Special care shall be given to ensure a stable positioning of reinforcement in the thin slabs ($t \leq 100$ mm).

For welded meshes and isolated bars in thin slabs, concrete covers against formworks shall be ensured by a sufficiently dense distribution of spacers.

Access of workers, as well as concrete casting and compacting, shall be made in such a way so to avoid displacements and deformations of steel reinforcement with respect to the intended positioning and shapes.

4.3 Finished product requirements

4.3.1 Geometrical properties

4.3.1.1 Production tolerances

iTech STANDARD PREVIEW
(standards.itech.ai)

The following values of *production tolerances* shall be used. The values are expressed in mm and refer to the measure described in Figure 1. Tolerances refer to the deviations with respect to the design (nominal) values indicated in project documentation (inclusive of possible cambers).

Measurement	Tolerance	Values (mm)
— Width "b" and short measurements ($b \leq 2\ 500$)	$\pm \Delta b$	$12 + b/140$
— Thickness "t" of thin flanges and plates ($t \leq 150$)	$+ \Delta t$	10
	$- \Delta t$	5
— Total depth "h" of any cross section ($h < 2\ 500$)	$\pm \Delta h$	$12 + h/140$
— Bow horizontal mis-alignment of lateral edges	$\pm \varepsilon$	$L/700$
— Camber "v" in vertical plane	$\pm \Delta v$	$L/700$

For the length "L" and the reinforcement placing "c", the corresponding permitted deviation ΔL and Δc are given in 4.3.1.1 of EN 13369:2004.

For the size of holes and openings 1,5 time the value of Δb tolerance may be assumed. For the overall positioning of holes and inserts 1,5 time the values of ΔL and Δb tolerances may be assumed. Other values may be given in project specifications.

For prestressed elements 1,5 time the value of Δv tolerance may be assumed; this includes the effects of prestressing tolerances. Other values may be given in project specifications.

Although production tolerances can refer to any dimension of the element, it is sufficient to follow the *Standard Method* of checking specified in point 5.2.

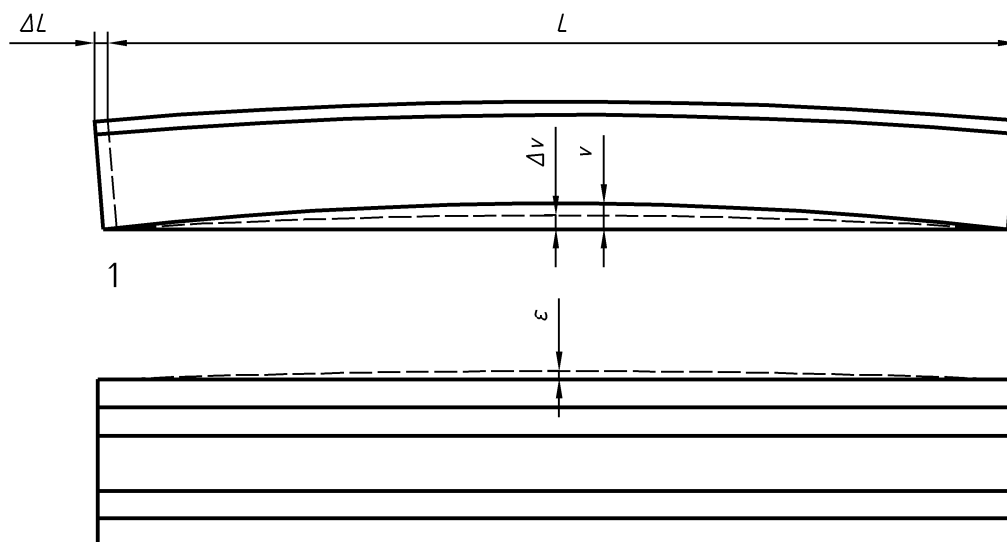

2 iTeh STANDARD PREVIEW
(standards.iteh.ai)

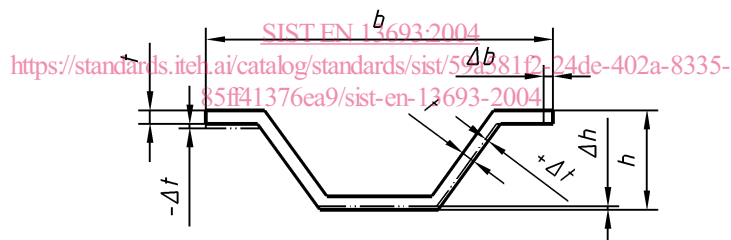

Key

- 1 Vertical
- 2 Horizontal
- 3 Cross section

Figure 1 — Measure of production tolerances

4.3.1.2 Minimum dimensions

Clause 4.3.1.2 of EN 13369:2004 shall apply.

4.3.2 Surface characteristics

For surface characteristics, 4.3.2 of EN 13369:2004 shall apply.

NOTE In addition to the possible cracking expected from calculation, cracking can occur in roof elements from normal function in some particular areas, such as the end edges of the ribs, the intersection lines of the different plates, the corners around holes or other shape discontinuities. Provided the width and the extension of these cracks are limited and there are no structural consequences, a simple local filling may be applied to restore the surface appearance.

Completion works of ready finished elements (such as painting, waterproofing, ...) are not covered by this document.

4.3.3 Mechanical resistance

4.3.3.1 General

For requirements on mechanical strength Clause 4.3.3 of EN 13369:2004 (referring to EN 1990:2002, EN 1992-1-1:2004 and EN 1992-1-2:2004) shall apply, except 4.3.3.4 dealing with verification by testing.

In particular, following 4.3.3.3 of EN 13369:2004, due to their structural arrangements with unusual design models, for the special roof elements dealt with in this standard, load tests up to failure on at least two full scale specimens of any type of product shall be performed before starting production (initial type testing – see 6.2) in order to verify the reliability of the design model assumed for calculation.

Specific additional information are given in informative Annex C and D.

4.3.3.2 Detailing

Overlapped splices of reinforcement shall be located out of the areas where the full strength is needed for the resistance of the element.

In any case they need a minimum dimension of the concrete section, defined by

$$t \geq 5 d_s$$

where

t is the minimum local thickness of the element, and

d_s is the diameter of the overlapped bars (or wires).

The minimum transverse spacing between two adjacent laps shall be $\geq 10 d_s$.

<https://standards.iteh.ai/catalog/standards/sist/59a581f2-24de-402a-8335-85ff41376ea9/sist-en-13693-2004>

4.3.4 Resistance and reaction to fire

4.3.4.1 Resistance to fire

Fire resistance, dealing with load-bearing capacity R, integrity E and insulation I of precast prestressed concrete roof elements, expressed in terms of classes, shall be defined following 4.3.4.1, 4.3.4.2 and 4.3.4.3 of EN 13369:2004.

NOTE Normally, with respect to fire resistance, the separating function EI is not required for the elements of concern.

4.3.4.2 Reaction to fire

For reaction to fire, 4.3.4.4 of EN 13369:2004 shall apply.

4.3.5 Acoustic properties

When required, the relevant acoustic properties of roof elements shall be declared following Clause 4.3.5 of EN 13369:2004.

4.3.6 Thermal properties

Reference shall be made to 4.3.6 of EN 13369:2004.

4.3.7 Durability

Clause 4.3.7 of EN 13369:2004 shall apply.

Referring to Table A.1 and Table A.2 of Annex A of EN 13369:2004, the upper surface of roof elements equipped with ready finished adherent covering is taken to be in ambient condition B, provided it is not specified otherwise.

The same ambient condition B can be referred to for the internal surfaces in hollow or sandwich roof elements and for closed box roof elements (see Annex B), provided it is not specified otherwise.

For plate parts (slab conditions of A.1 of EN 13369: 2004) of roof elements the concrete cover given for reinforcing and prestressing steel in slab geometry shall apply.

4.3.8 Other requirements

4.3.8.1 Safety in handling

Clause 4.3.8.1 of EN 13369:2004 shall apply.

5 Test methods

5.1 Tests on concrete

Clause 5.1 of EN 13369:2004 shall apply.

5.2 Measuring of dimensions

The *Standard Method* of measuring the dimensions related to the production tolerances of 4.3.1.1 is specified below.

Except for reinforcement position in the section, measurements are taken in the demoulded finished element.

- a) the *total length* “*L*” is taken following the special indications given in the technical specifications of the product. (By rule three readings are taken, one at each edge and one in a central position);
- b) the *total width* “*b*” is taken in correspondence of three cross sections, two near the ends and one at the midspan;
- c) the *thicknesses* “*t*” are taken at the same three cross sections of item *b*, in the critical positions of the slabs indicated by the technical specifications of the product (at least one for each lateral flange);
- d) the *total depth* “*h*” is taken (by proper outside collimator systems) in correspondence of the same three cross sections of item *b*;
- e) the bow misalignment “*ε*” is taken, for each lateral edge, at the midspan position with respect to its end points;
- f) the *camber* “*v*” at midspan is taken with respect to the end support straight line and compared to the design camber v_0 , adjusted with the computed deformation v_c due to applied loads ($\Delta v = v - v_0 - v_c$);
- g) *concrete cover* is taken at the lower side of the lateral flanges, in the critical positions indicated by the technical specifications of the product (at least one for each lateral flange in the three cross section of item *b*).

For the measurements above listed (at least for items *a*, *b*, *e* and *f*), the element shall be set in an arrangement as similar as possible to its final position in the structure.

Following the special features of the products, proper adaptations and variations to the Standard Method can be given by the technical specifications of the product.

The *reinforcement position*, together with the setting of prestressing tendons and special devices, is verified following the pertinent items of Table D.3.2 in Table D.3 of EN 13369:2004.

5.3 Weight of the elements

Clause 5.3 of EN 13369:2004 shall apply.

5.4 Load test of elements

Annex E gives the standard method for flexural load tests on full scale specimens of roof elements.

6 Evaluation of conformity

6.1 General

Clause 6.1 of EN 13369:2004 shall apply.

6.2 Type testing

Clause 6.2 of EN 13369:2004 shall apply.

6.3 Factory production control

NOTE The missing numbers correspond to the clauses of EN 13369 included in the general references made in this subchapter.

Clause 6.3 of EN 13369:2004, except 6.3.6.5, shall apply.

iTeh STANDARD PREVIEW
(standards.iteh.ai)

6.3.6.5 Finished products

Compliance verification on the finished products shall be performed following, in addition to items 3 to 5 of Table D.4.1 of EN 13369:2004, the control chart of Table 1 of this document. Other verifications can be performed where a special necessity arises.

The checks shall be carried out at the earliest time possible, preferably in the factory, and never after the precast units have been received and accepted at the site.

Table 1 — Finished product inspection

Subject	Aspect	Method	Frequency	Registration
Elements	surface finish	visual inspection	every element	notice of imperfections
Elements	total length	see point 5.2(a)	every 10 elements	notation in the record form
Elements	thickness	see point 5.2(c)	every 10 elements	notation in the record form
Elements	concrete cover	see point 5.2(g)	every 10 elements	notation in the record form
Elements	camber*	see point 5.2(f)	every month or 1/100 elements	notation in the record form
Elements	other production tolerances	see point 5.2(b)-(d)-(e)	every year or 1/600 elements	notation in the record form
Elements (all types)	mechanical strength (failure conditions)	see Annex E	initial type tests on 2 elements	proper report
Elements (type f of Annex C)	mechanical strength (service conditions)	see Annex E	every 6 months on 1 element	proper report

* See 4.3.1.1 and Figure 1.

The manufacturer shall keep the records of the elements produced (position number, date of casting and construction data) for the required period of archiving and make them available when required.

7 Marking and labelling

Clause 7 of EN 13369:2004 shall apply.

NOTE For CE marking see Annex ZA.

8 Technical documentation

Considering also 4.3.3.2, the detailing of the element, with respect to geometrical data and complementary properties of materials and inserts, shall be given in technical documentation, which includes the construction data, such as the dimensions, the tolerances, the layout of reinforcement, the concrete cover, the expected transient and final support conditions and lifting conditions.

The composition of technical documentation is given in Clause 8 of EN 13369:2004.

iTeh STANDARD PREVIEW
(standards.iteh.ai)

[SIST EN 13693:2004](https://standards.iteh.ai/catalog/standards/sist/59a581f2-24de-402a-8335-85ff41376ea9/sist-en-13693-2004)

<https://standards.iteh.ai/catalog/standards/sist/59a581f2-24de-402a-8335-85ff41376ea9/sist-en-13693-2004>