



Designation: C1579 – 21

# Standard Test Method for Evaluating Plastic Shrinkage Cracking of Restrained Fiber Reinforced Concrete (Using a Steel Form Insert)<sup>1</sup>

This standard is issued under the fixed designation C1579; the number immediately following the designation indicates the year of original adoption or, in the case of revision, the year of last revision. A number in parentheses indicates the year of last reapproval. A superscript epsilon ( $\epsilon$ ) indicates an editorial change since the last revision or reapproval.

## 1. Scope\*

1.1 This test method compares the surface cracking of fiber reinforced concrete panels with the surface cracking of control concrete panels subjected to prescribed conditions of restraint and moisture loss that are severe enough to produce cracking before final setting of the concrete.

1.2 This test method can be used to compare the plastic shrinkage cracking behavior of different concrete mixtures containing fiber reinforcement.

1.3 The values stated in SI units are to be regarded as standard. No other units of measurement are included in this standard.

1.4 *This standard does not purport to address all of the safety concerns, if any, associated with its use. It is the responsibility of the user of this standard to establish appropriate safety, health, and environmental practices and determine the applicability of regulatory limitations prior to use. (Warning—fresh hydraulic cementitious mixtures are caustic and may cause chemical burns to skin and tissue upon prolonged exposure.<sup>2</sup>)*

1.5 *This international standard was developed in accordance with internationally recognized principles on standardization established in the Decision on Principles for the Development of International Standards, Guides and Recommendations issued by the World Trade Organization Technical Barriers to Trade (TBT) Committee.*

## 2. Referenced Documents

2.1 *ASTM Standards:*<sup>3</sup>

**C125 Terminology Relating to Concrete and Concrete Aggregates**

<sup>1</sup> This test method is under the jurisdiction of ASTM Committee C09 on Concrete and Concrete Aggregates and is the direct responsibility of Subcommittee C09.42 on Fiber-Reinforced Concrete.

Current edition approved June 1, 2021. Published June 2021. Originally published in 2006. Last previous edition approved in 2013 as C1579 – 13. DOI: 10.1520/C1579-21.

<sup>2</sup> Section on Safety Precautions, Manual of Aggregate and Concrete Testing, *Annual Book of ASTM Standards*, Vol 04.02.

<sup>3</sup> For referenced ASTM standards, visit the ASTM website, www.astm.org, or contact ASTM Customer Service at service@astm.org. For *Annual Book of ASTM Standards* volume information, refer to the standard's Document Summary page on the ASTM website.

**C143/C143M Test Method for Slump of Hydraulic-Cement Concrete**

**C192/C192M Practice for Making and Curing Concrete Test Specimens in the Laboratory**

**C403/C403M Test Method for Time of Setting of Concrete Mixtures by Penetration Resistance**

**C670 Practice for Preparing Precision and Bias Statements for Test Methods for Construction Materials**

## 3. Terminology

3.1 *Definitions:*

3.1.1 For definitions of terms used in this test method, refer to Terminology **C125**.

## 4. Summary of Test Method

4.1 Panels of control concrete and fiber reinforced concrete are prepared in a prescribed manner and are exposed to controlled drying conditions after finishing. The drying conditions (see **Note 1**) are intended to be severe enough to induce plastic shrinkage cracking in test panels made of control concrete. The evaporation rate from a free water surface is monitored by pans placed next to the panels in the environmental chamber.

**NOTE 1**—An important parameter in this method is the rate of evaporative water loss, which is controlled by the atmospheric conditions surrounding the test specimens. Since the concrete specimens will not always have the same rate of water evaporation as the pan of water (due to evaporative and bleeding effects), the rate of evaporation of 1.0 kg/m<sup>2</sup>·h from the pan of water represents the minimum evaporation rate that must be attained for this test (**1**).<sup>4</sup> The moisture loss from the concrete test panels can also be monitored and reported, however, the rate of evaporation from the free surface of the water in the pan is the parameter that should be used to quantify the drying environment.

4.2 The test is terminated at the time of final setting of the concrete determined in accordance with Test Method **C403/C403M**. At 24 h from initial mixing, the average crack width is determined.

4.3 A cracking reduction ratio (CRR) is computed from the average crack width for the fiber-reinforced concrete panels and the average crack width for the control concrete panels.

<sup>4</sup> The boldface numbers in parentheses refer to the list of references at the end of this standard.

\*A Summary of Changes section appears at the end of this standard

5. Significance and Use

5.1 The test method is intended to evaluate the effects of evaporation, settlement, and early autogenous shrinkage on the plastic shrinkage cracking performance of fiber reinforced concrete up to and for some hours beyond the time of final setting (see Terminology C125).

5.2 The measured values obtained from this test may be used to compare the performance of concretes with different mixture proportions, concretes with and without fibers, concretes containing various amounts of different types of fibers, and concretes containing various amounts and types of admixtures. For meaningful comparisons, the evaporative conditions during test shall be sufficient to produce an average crack width of at least 0.5 mm in the control specimens (2, 3) (see Note 2). In addition, the evaporation rate from a free surface of water shall be within ± 5 % for each test.

NOTE 2—To achieve evaporation rates that result in a crack of at least

0.5 mm in the control specimens, it may be necessary to use an evaporation rate higher than that discussed in Note 1.

5.3 This method attempts to control atmospheric variables to quantify the relative performance of a given fresh concrete mixture. Since many other variables such as cement fineness, aggregate gradation, aggregate volume, mixing procedures, slump, air content, concrete temperature and surface finish can also influence potential cracking, attention shall be paid to keep these as consistent as possible from mixture to mixture.

6. Apparatus

6.1 Molds:

6.1.1 For maximum coarse aggregate size equal to or less than 19 mm, use a mold with a depth of 100 mm ± 5 mm and rectangular dimensions of 355 mm ± 10 mm by 560 mm ± 15 mm (see Fig. 1). The mold can be fabricated from metal, plastic, or plywood.

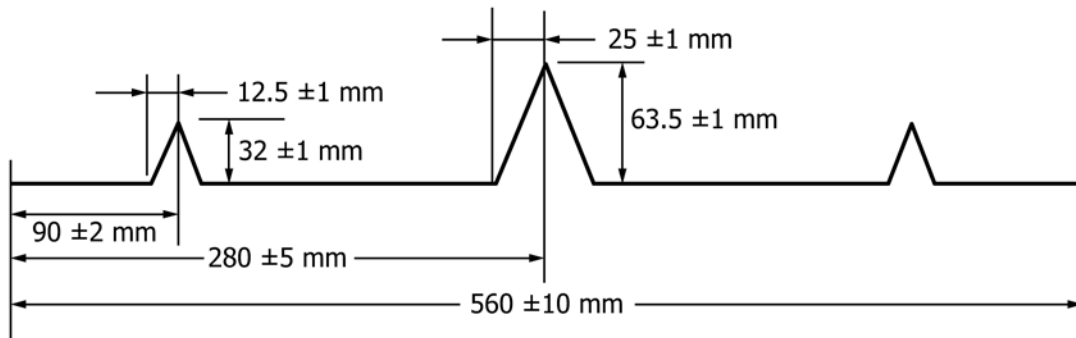
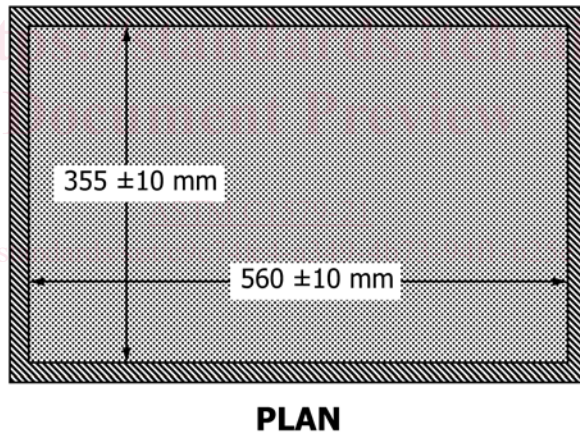
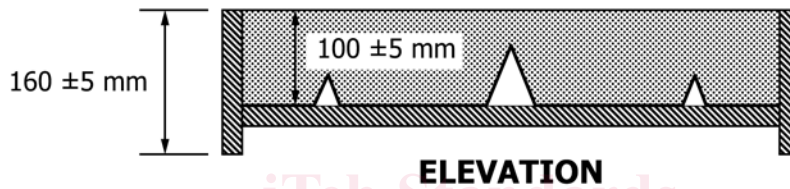

Stress Riser Geometry

FIG. 1 Specimen and Stress Riser Geometry (4, 3)

NOTE 3—If plywood is used for molds, the plywood should have low moisture absorption. The mold should be constructed to be lightweight and stiff. The molds, when properly constructed, should last for approximately 50 uses.

6.1.2 This test method is designed for aggregate less than or equal to 19 mm. For coarse aggregate greater than 19 mm, the depth of the mold shall be at least 65 mm plus at least 2 times the maximum coarse aggregate size.

6.2 *Stress Riser and Internal Restraints*—The internal restraints and stress riser shall be bent from one piece of sheet metal, as illustrated in Fig. 1, or made from a solid piece of steel. The sheet metal shall have a thickness of  $1.2 \text{ mm} \pm 0.05 \text{ mm}$  (18 gauge) (see Fig. 1 and Ref 2). Two  $32 \text{ mm} \pm 1 \text{ mm}$  high restraints are placed  $90 \text{ mm} \pm 2 \text{ mm}$  inward from each end of the mold. The central stress riser is  $64 \text{ mm} \pm 2 \text{ mm}$  high and serves as an initiation point for cracking. This sheet metal stress riser with internal restraints shall fit at the bottom of the mold.

6.2.1 Use form release oil to coat the metal insert and mold sides to reduce bond with concrete. The insert and mold are considered to be properly oiled when the entire surface is coated and excess oil has been removed with a clean, dry rag.

6.3 *Variable Speed Fan(s)*—The fan(s) used shall be capable of achieving a wind speed of more than 4.7 m/s over the entire test panel surface area.

6.4 *Environmental Chamber*—The use of a fan box in an environmental chamber is a method for producing a uniform airflow over the panel surface (see Fig. 2). A clear cover over the panels will aid in obtaining uniform airflow and allow for observation of cracking. Another method of producing uniform airflow is to use a specifically designed environmental chamber as shown in Fig. 3. A commercially available heater, humidifier, and dehumidifier can be used to maintain the specified environmental condition. This test is conducted using either apparatus shown in Fig. 2 or Fig. 3 by exposing the panels to an evaporation rate of at least  $1.0 \text{ kg/m}^2\cdot\text{h}$  (see Note 1). For the standard test, the temperature must be maintained at  $36 \text{ }^\circ\text{C} \pm 3 \text{ }^\circ\text{C}$ , the relative humidity must be  $30 \pm 10 \%$ , and the wind velocity must be sufficient to maintain the minimum evaporation rate during the test.

NOTE 4—Before casting the concrete panels, atmospheric variables in the environmental facility should be checked to determine that the necessary evaporative conditions can be achieved. A wind velocity of 4.7 m/s should be sufficient to achieve the minimum specified evaporation rate, but a higher wind velocity may be needed to obtain sufficient average crack width in some control panels.

6.5 *Sensors*—Use temperature, humidity, and wind velocity sensors to measure ambient air and concrete surface temperature to the nearest  $0.5 \text{ }^\circ\text{C}$ , relative humidity to the nearest 1 %, and air speed to the nearest 0.1 m/s.

6.6 *Vibrating Platform*—Any device that can fully consolidate the test panel that meets minimum frequency requirements as stated in Practice C192/C192M for an external vibrator is suitable.

6.7 *Surface Finishing Equipment*—An angle iron screed shall be used for the concrete after vibration. A magnesium, steel, or wood trowel shall be used for finishing the surface of the specimen after screeding.

6.8 *Monitoring Pan*—A pan suitable for exposing water to the air stream for each concrete test panel is required. The sides of the pan shall be vertical. The pan shall be of sufficient size to expose at least  $0.1 \text{ m}^2 \pm 0.01 \text{ m}^2$  of water to the air stream. The exposed lip of the pan shall not extend more than 5 mm above the water level at the start of the test.

NOTE 5—The test panels and monitoring pans can be placed in an environmental chamber designed for this test method (see Fig. 3) or the pans can be placed downstream from panels in a fan box (see Fig. 2).

6.9 *Scale*—If the rate of moisture loss from test panels is required by the specifier of tests, weigh test panels with a scale having a capacity of at least 100 kg and accurate to within 0.1 % of the test load. Weigh the evaporation rate monitoring pans with a balance or scale having a capacity of at least 3 kg and accurate to within 5 g.

6.10 *Crack Measurement Tool*—Optical hand-held microscope, crack comparator, or image analysis system can be used. The measurement tool should be capable of measuring crack width to at least the nearest 0.05 mm. If an automated image analysis system is used, it should be demonstrated to provide an accurate measurement. To demonstrate the accuracy of the measurement, the system shall be used to measure a 0.5 mm notch that is machined into a piece of steel and the reported notch width shall be within  $\pm 0.05 \text{ mm}$  of the machined width.

## 7. Sampling, Test Specimens, and Test Units

7.1 *Test Panels*—Cast test panels in accordance with the applicable provisions of Practice C192/C192M, using the same source of materials, preparation, mixing and finishing procedures.

7.2 *Test Unit*—A test unit is comprised of at least two control specimens and at least two fiber reinforced concrete specimens with the same mixture proportions. A group of two control specimens has to be tested each time in order to determine the plastic shrinkage crack reduction of fiber reinforced concrete.

## 8. Procedure

8.1 Determine the slump of each mixture in accordance with Test Method C143/C143M.

8.2 Fabricate specimens for setting time determination in accordance with Test Method C403/C403M. If fiber reinforced concrete cannot be wet sieved readily, use the control concrete specimen to measure time of final setting of both the control and the fiber-reinforced mixtures. Place the time of setting specimens in the air stream so that they are exposed to the same environmental conditions as the plastic shrinkage panels.

8.3 Fill the panel molds using one layer. Consolidate the concrete with external vibration until the concrete is approximately level with the top of the mold. Screed each specimen perpendicular to the stress riser three times.

8.4 After screeding, trowel specimens using a predetermined number of passes. If moisture loss from the panel is to be determined, remove any waste concrete adhering to the outside of the mold and weigh each panel while in the mold.

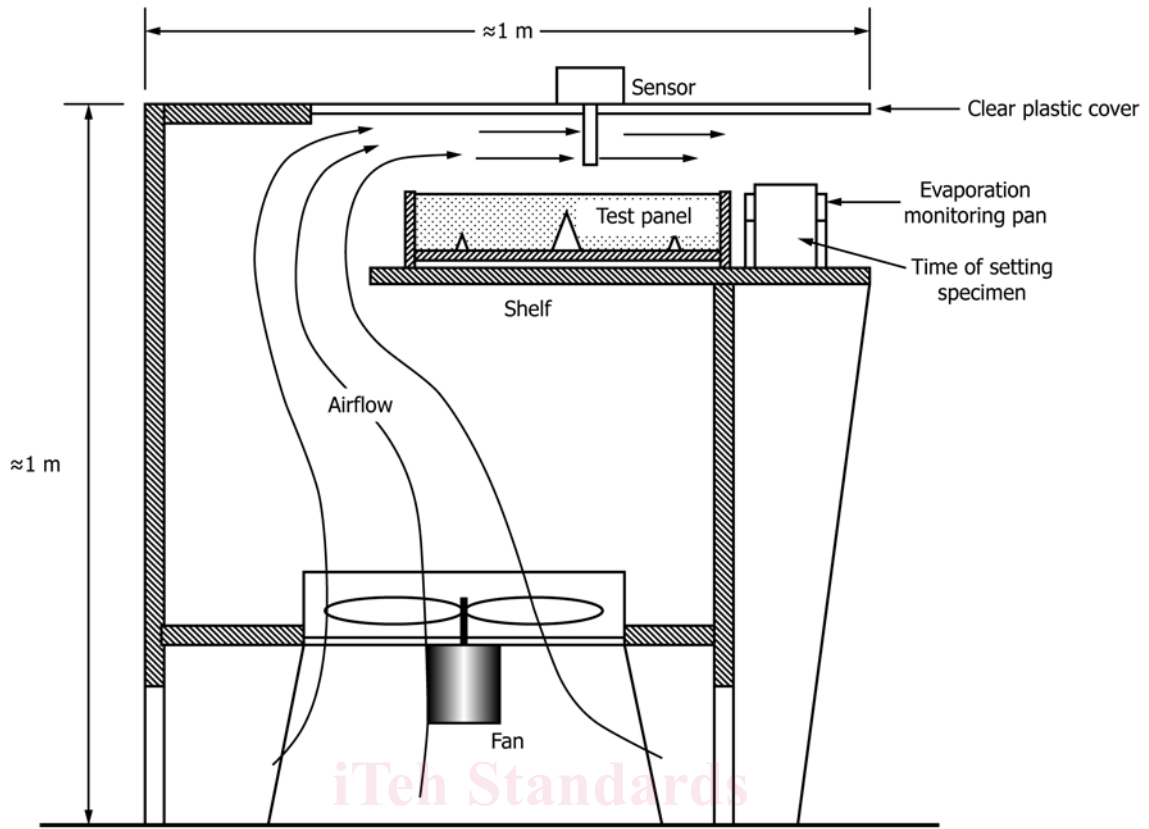

**ELEVATION**

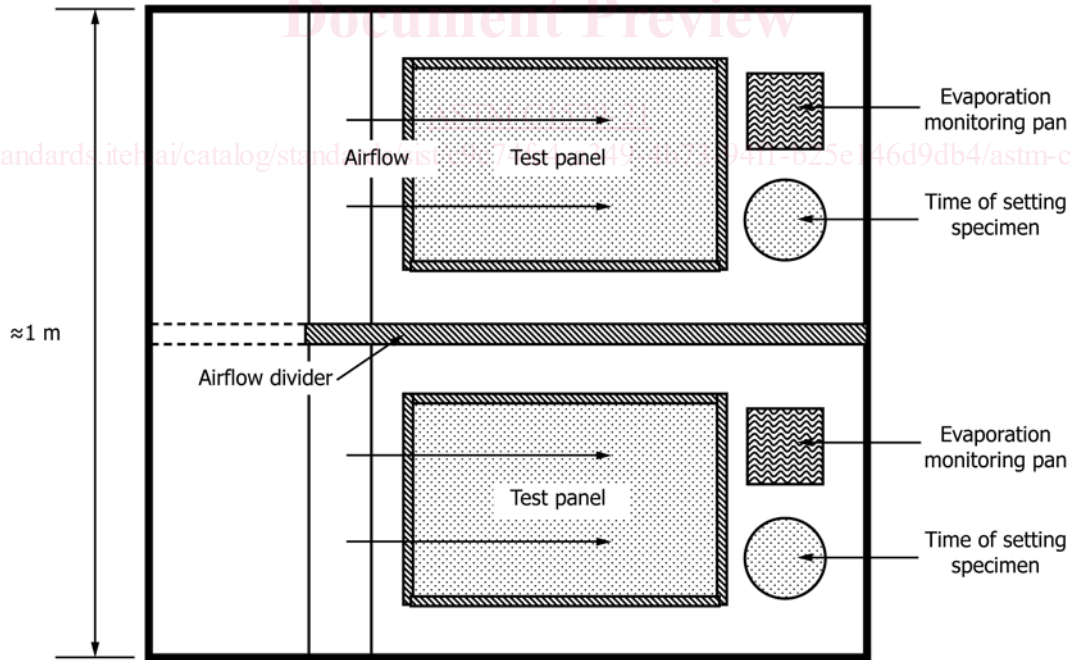

**PLAN**

FIG. 2 Example of Fan Box to Maintain Environmental Conditions (2) (Not to Scale)