



Designation: F1926/F1926M – 14 (Reapproved 2021)

# Standard Test Method for Dissolution Testing of Calcium Phosphate Granules, Fabricated Forms, and Coatings<sup>1</sup>

This standard is issued under the fixed designation F1926/F1926M; the number immediately following the designation indicates the year of original adoption or, in the case of revision, the year of last revision. A number in parentheses indicates the year of last reapproval. A superscript epsilon ( $\epsilon$ ) indicates an editorial change since the last revision or reapproval.

## 1. Scope

1.1 This test method covers calcium phosphate materials intended for use in surgical implant applications.

1.2 The material(s) shall be representative of that produced for sale. It shall have been produced and processed under standard manufacturing conditions.

1.3 The materials may be in the form of powders, granules, spall material, fabricated forms, or coatings; and may be porous, nonporous, textured, and other implantable topographical substrate form representative of the end-use product.

1.4 The calcium phosphate material may constitute the only material in a substrate or it may be one of multiple materials so long as all other materials present do not dissolve under the test conditions described in this test method.

1.5 The values stated in either SI units or inch-pound units are to be regarded separately as standard. The values stated in each system may not be exact equivalents; therefore, each system shall be used independently of the other. Combining values from the two systems may result in nonconformance with the standard.

1.6 *This standard does not purport to address all of the safety concerns, if any, associated with its use. It is the responsibility of the user of this standard to establish appropriate safety, health, and environmental practices and determine the applicability of regulatory limitations prior to use.*

1.7 *This international standard was developed in accordance with internationally recognized principles on standardization established in the Decision on Principles for the Development of International Standards, Guides and Recommendations issued by the World Trade Organization Technical Barriers to Trade (TBT) Committee.*

<sup>1</sup> This test method is under the jurisdiction of ASTM Committee F04 on Medical and Surgical Materials and Devices and is the direct responsibility of Subcommittee F04.13 on Ceramic Materials.

Current edition approved June 1, 2021. Published June 2021. Originally published in 1998. Last previous edition approved in 2014 as F1926/F1926M – 14. DOI: 10.1520/F1926\_F1926M-14R21.

## 2. Referenced Documents

2.1 *ASTM Standards:*<sup>2</sup>

**E691** Practice for Conducting an Interlaboratory Study to Determine the Precision of a Test Method

**F1088** Specification for Beta-Tricalcium Phosphate for Surgical Implantation

**F1185** Specification for Composition of Hydroxylapatite for Surgical Implants

## 3. Terminology

3.1 *Definitions of Terms Specific to This Standard:*

3.1.1 *calcium phosphate, n*—any one of a number of inorganic chemical compounds containing calcium and phosphate ions as its principal constituents.

3.1.2 *coating, n*—layer of material mechanically or chemically adhering to the surface of a substrate.

## 4. Significance and Use

4.1 Aspects of the biological response to calcium phosphate materials in soft tissue and bone have been reported from laboratory studies and clinical use (**1-11**).<sup>3</sup>

4.2 The requirements of this test method apply to calcium phosphate materials such as calcium hydroxyapatite (see Specification **F1185**), beta-tricalcium phosphate (see Specification **F1088**), and biphasic mixtures thereof with or without intentional addition of other minor (<10 %) components.

4.3 This test method is limited to the laboratory evaluation of the dissolution rate of a calcium phosphate material. No correlation of the results to in-vivo performance is implied. Therefore, it is recommended that a control material be included in the evaluation. The control material can be a standardized material such as NIST SRM 2910 or a historical control.

<sup>2</sup> For referenced ASTM standards, visit the ASTM website, www.astm.org, or contact ASTM Customer Service at service@astm.org. For *Annual Book of ASTM Standards* volume information, refer to the standard's Document Summary page on the ASTM website.

<sup>3</sup> The boldface numbers in parentheses refer to the list of references at the end of this standard.

## 5. Dissolution Media

5.1 Water used for preparing reagents or dissolution media shall be degassed carbon dioxide free deionized or distilled water and have less than 0.1 ppm of residual  $\text{Ca}^{++}$  ion. Optionally, the water can be degassed *in situ*.

5.2 *Unbuffered Water Media*—Deionized or distilled water containing  $8 \times 10^{-5}$  M NaCl,  $8 \times 10^{-5}$  M  $\text{CaCl}_2$ , and  $5 \times 10^{-5}$  M  $\text{K}_3(\text{PO}_4)$ .

5.3 *pH 5.5 MES Buffer Media*—1.0 M MES, [2-(N-morpholino)ethanesulfonic acid] having a pH of 5.5 at  $37 \pm 0.5$  °C and containing  $8 \times 10^{-5}$  M NaCl,  $8 \times 10^{-5}$  M  $\text{CaCl}_2$ , and  $5 \times 10^{-5}$  M  $\text{K}_3(\text{PO}_4)$ .

5.3.1 A buffer concentration of 1.0 M will usually provide sufficient buffer capacity to keep the solution within  $\pm 0.1$  pH units of the initial value. If this is not the case, the buffer capacity should be adjusted accordingly.

5.3.2 The pH shall be adjusted to 5.5 at  $37 \pm 0.5$  °C using HCl or NaOH solutions.

5.4 *pH 7.4 TRIS Buffer Media*—1.0 M TRIS, [Tris(hydroxymethyl)aminomethane] having a pH of 7.4 at  $37 \pm 0.5$  °C and containing  $8 \times 10^{-5}$  M NaCl,  $8 \times 10^{-5}$  M  $\text{CaCl}_2$ , and  $5 \times 10^{-5}$  M  $\text{K}_3(\text{PO}_4)$ .

5.4.1 A buffer concentration of 1.0 M will usually provide sufficient buffer capacity to keep the solution within  $\pm 0.1$  pH units of the initial value. If this is not the case, the buffer capacity should be adjusted accordingly.

5.4.2 The pH shall be adjusted to 7.4 at  $37 \pm 0.5$  °C using HCl or NaOH solutions.

## 6. Analytical Parameters

6.1 The following procedure should be performed with each of the media listed:

6.1.1 The dissolution rate shall be measured under the conditions of a constant ratio of initial material mass (mg) to total dissolution media volume (mL). The ratio of test material mass to dissolution media shall typically be between 1 to 4 mg/mL.

6.1.2 The dissolved  $\text{Ca}^{++}$  concentration ( $\pm 1$  ppm) shall be measured as soon as practical after the start of the experiment and at appropriate time intervals thereafter to allow determination of changes with time.

## 7. Analytical Procedures

7.1 Make pH measurements with an appropriately calibrated pH meter and probe.

7.2 Measure the  $\text{Ca}^{++}$  concentrations potentiometrically. Ionic strength adjuster (ISA) shall be added as required by the electrode manufacturer. Other methods (for example, colorimetrically, atomic absorption (AA), inductively coupled plasma (ICP) spectroscopy, or inductively coupled plasma mass spectroscopy (ICP/MS)) may be used if equivalency can be demonstrated.

7.3 An appropriate bacteriostat (for example, 0.1 v/v % Hibiclens or 0.1 w/v % sodium azide) may be added to the dissolution media before the start of an experiment.

## 8. Dissolution Apparatus

8.1 The dissolution vessel shall be of such design as to easily accommodate the test specimen, the stirrer, and the specific ion-electrode and reference electrode assemblies. It shall also be isolated from the atmosphere by an oxygen- and carbon dioxide-free inert gas purge.

8.1.1 A convenient apparatus (see Fig. 1) is a 100-mL jacketed beaker with circulating water from a thermostatically controlled vessel. A flat piece of polyethylene or other inert plastic with appropriate holes drilled to accommodate the probes, sample holder, and purge gas tube can serve as a lid.

8.2 The vessel shall be of appropriate dimensions to contain the required volume of dissolution media at a level to keep the test material completely submerged during the test and facilitate sufficient stirring action from the magnetic stirrer bar.

8.3 The stirrer assembly shall be capable of maintaining a constant stirring rate of  $100 \pm 20$  rpm.

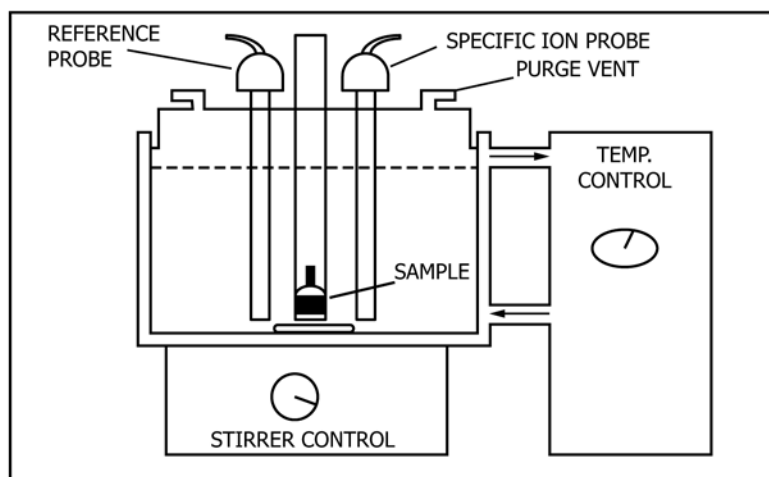

FIG. 1 Dissolution Apparatus

8.3.1 *Magnetic Stirrer Bar*—Approximately 8-mm [0.31-in.] diameter, 28-mm [1.125-in.] length, polytetrafluoroethylene (PTFE)-coated.

8.3.2 *Overhead Stirrer*—An overhead stirrer is preferred especially when testing granulate, forms, or plates so as to avoid degradation of the materials by the stirring bar.

8.3.3 A different type of stirrer design and stirring rate may be used provided equivalence in experimental results can be demonstrated.

8.4 The dissolution vessel shall be thermostatically controlled at  $37 \pm 0.5$  °C.

8.5 The dissolution apparatus may include various data recording and storage devices, strip chart recorders, computers, and so forth to facilitate continuous monitoring throughout the duration of the experiment.

## 9. Preparation of Test Specimens

### 9.1 Coatings:

9.1.1 The test specimen shall be manufactured from the same materials and processes as substrates produced for sale.

9.1.1.1 The standard test specimen is a flat plate about 3.5 by 3.5 cm [1.375 by 1.375 in.].

(1) The coated area on this plate would be about 25 by 30 mm [1 by 1.125 in.]. See Fig. 2.

(2) This test specimen may be either attached by screwing it to rod or placed on a polymeric mesh above the stir bar.

9.1.1.2 The alternative test specimen for evaluating coating materials is defined in Fig. 3.

9.1.1.3 The user may justify another test coupon geometry.

9.1.1.4 This can be conducted on particles scraped from the coating.

(1) The scraped particles shall be dispersed in the dissolution solution and stirred by an overhead stirrer to minimize degradation by the stirring mechanism.

9.1.2 The test specimen shall be manufactured from the same materials and processes as substrates produced for sale.

9.1.2.1 The test specimen shall have the upper shank threaded so as to mate with an appropriate supporting shaft as shown in Fig. 1.

9.1.2.2 By appropriate masking, or other techniques, the coating shall be applied only to the central  $1.3 \pm 0.013$  cm [ $0.5 \pm 0.005$  in.] of the test specimen.

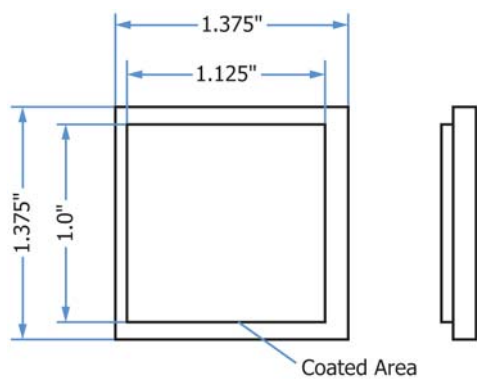

FIG. 2 Flat Plate Test Specimen

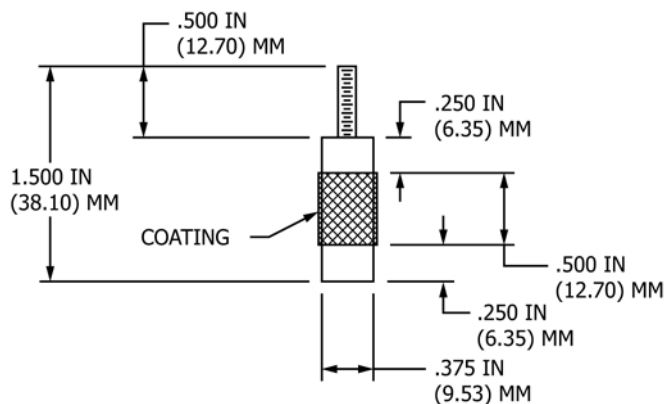

FIG. 3 Test Specimen and Coating

9.2 *Fabricated Forms*—A fabricated form shall be tested in the form it is provided as a product. The form shall be placed on a polymeric screen over the stir bar or under a stirrer so that there is no contact with the stirring mechanism.

9.3 *Powders and Granules*—Powders and granules shall be tested in the form intended for use.

9.3.1 Fine powders under  $250 \mu\text{m}$  shall be dispersed in the dissolution solution and stirred by an overhead stirrer to minimize degradation by the stirring mechanism.

9.3.2 Granulate and larger powders ( $\geq 250 \mu\text{m}$ ) shall be spread on a polymeric screen so as to avoid degradation by the stirring bar or the overhead stirring mechanism.

## 10. Procedure for Monitoring Changes in pH and Calcium Concentrations

10.1 Prepare the test specimen as described in Section 8.

10.2 Procure the appropriate volume of dissolution media needed for the experiment and equilibrate at  $37 \pm 0.5$  °C.

10.3 Sufficient sample for at least six replicate tests should be prepared.

10.4 Calibrate the pH probe and any other analytical instrumentation to be used immediately before starting the experiment or use as recommended by the manufacturers.

10.5 Adjust the stirrer assembly to  $100 \pm 20$  rpm.

10.6 Assemble the dissolution apparatus (see Fig. 1). The dissolution media, all calibrated sensing electrodes, and the stirrer should be in place and operating. However, do not include the test specimen. Then equilibrate this assembly at  $30 \pm 0.5$  °C.

10.7 Record the initial pH of the test media.

10.8 Calibrate the calcium-specific ion electrode as recommended by the manufacturer except use the same test media for preparing the calibration standards as will be used in the experiment.

10.9 Set the experiment timing device to zero.

10.10 When ready to begin the experiment, add the test specimen to the dissolution vessel, and make any necessary adjustments to the equipment.