



Designation: ~~D3032—21~~ D3032 – 21a

# Standard Test Methods for Hookup Wire Insulation<sup>1</sup>

This standard is issued under the fixed designation D3032; the number immediately following the designation indicates the year of original adoption or, in the case of revision, the year of last revision. A number in parentheses indicates the year of last reapproval. A superscript epsilon ( $\epsilon$ ) indicates an editorial change since the last revision or reapproval.

*This standard has been approved for use by agencies of the U.S. Department of Defense.*

## 1. Scope\*

1.1 These test methods cover procedures for testing hookup wire.

1.2 For the purposes of these test methods, hookup wire insulation includes all components of the insulation system used on single insulated conductors or an assembly of single insulated conductors such as a cable bundle and harness or flat ribbon cable. The insulating materials include not only the primary insulation over the conductor, but also insulating jackets over shielded constructions.

1.3 These test methods and their locations are as follows:

<del>Axial Stability (Longitudinal Change) After Thermal Exposure</del>	<del>21</del>
<del>Axial Stability (Longitudinal Change) After Thermal Exposure</del>	<del>20</del>
<del>Bondability of Insulation to Potting Compounds</del>	<del>19</del>
<del>Bondability of Insulation to Potting Compounds</del>	<del>18</del>
<del>Capacitance</del>	<del>9 to 12</del>
<del>Capacitance</del>	<del>9 to 11</del>
<del>Cold Bend Test</del>	<del>26</del>
<del>Cold Bend Test</del>	<del>25</del>
<del>Concentricity</del>	<del>26</del>
<del>Concentricity</del>	<del>25</del>
<del>Crush Resistance</del>	<del>20</del>
<del>Crush Resistance</del>	<del>19</del>
<del>Dielectric Breakdown Voltage</del>	<del>5</del>
<del>Dimensions</del>	<del>15</del>
<del>Dimensions</del>	<del>14</del>
<del>Dry-arc Tracking</del>	<del>29</del>
<del>Dry-arc Tracking</del>	<del>28</del>
<del>Dynamic Cut-through</del>	<del>22</del>
<del>Dynamic Cut-through</del>	<del>21</del>
<del>Fluid Immersion</del>	<del>23</del>
<del>Fluid Immersion</del>	<del>22</del>
<del>High Temperature Shock</del>	<del>24</del>
<del>High Temperature Shock</del>	<del>23</del>
<del>Insulation-Continuity Proof Tests</del>	<del>13</del>
<del>Insulation-Continuity Proof Tests</del>	<del>12</del>
<del>Insulation Resistance</del>	<del>6</del>
<del>Partial Discharge (Corona) Inception and Extinction Voltage</del>	<del>25</del>
<del>Partial Discharge (Corona) Inception and Extinction Voltage</del>	<del>24</del>

<sup>1</sup> These test methods are under the jurisdiction of ASTM Committee D09 on Electrical and Electronic Insulating Materials and are the direct responsibility of Subcommittee D09.07 on Electrical Insulating Materials.

Current edition approved Jan. 1, 2021; April 1, 2021. Published February 2021; June 2021. Originally approved in 1972. Last previous edition approved in 2016 as D3032 – 16; D3032 – 21. DOI: 10.1520/D3032-21.10.1520/D3032-21A.

\*A Summary of Changes section appears at the end of this standard

<del>Relative Thermal Life and Temperature Index</del>	<del>14</del>
Relative Thermal Life and Temperature Index	13
<del>Strip Force</del>	<del>27</del>
Strip Force	26
<del>Surface Resistance</del>	<del>27</del>
Surface Resistance	26
<del>Tensile Properties</del>	<del>17</del>
Tensile Properties	16
<del>Vertical Flame</del>	<del>18</del>
Vertical Flame	17
Vertical Flame Test A	18.5
	(Test Method
	D8354)
<del>Vertical Flame Test B</del>	<del>18.6 – 18.11.4</del>
Vertical Flame Test B	17.6 – 17.11.4
Voltage Rating of Hook-Up Wire	Annex A1
Voltage Withstand Test	8
<del>Wet-Arc-tracking</del>	<del>28</del>
Wet Arc-tracking	27

1.4 The values stated in SI units are to be regarded as standard. The values given in parentheses after SI units are provided for information only and are not considered standard.

1.5 *This standard measures and describes the response of materials, products, or assemblies to heat and flame under controlled conditions, but does not, by itself, incorporate all factors required for fire hazard or fire risk assessment of the materials, products, or assemblies under actual fire conditions.*

1.6 *Fire testing is inherently hazardous. Adequate safeguards for personnel and property shall be employed in conducting these tests.*

1.7 *This standard does not purport to address all of the safety concerns, if any, associated with its use. It is the responsibility of the user of this standard to establish appropriate safety, health, and environmental practices and determine the applicability of regulatory limitations prior to use. For specific warning statements, see [12.2.1](#), [12.4.1.8](#), [18.1.3](#), [17.1.3](#), [25.4.4](#), and [Note 19.18](#).*

1.8 *This international standard was developed in accordance with internationally recognized principles on standardization established in the Decision on Principles for the Development of International Standards, Guides and Recommendations issued by the World Trade Organization Technical Barriers to Trade (TBT) Committee.*

## 2. Referenced Documents

[ASTM D3032-21a](#)

<https://standards.iteh.ai/catalog/standards/sist/fc19864f-ee5f-45a9-802e-31b7216ed199/astm-d3032-21a>

### 2.1 *ASTM Standards*.<sup>2</sup>

- [D149 Test Method for Dielectric Breakdown Voltage and Dielectric Strength of Solid Electrical Insulating Materials at Commercial Power Frequencies](#)
- [D150 Test Methods for AC Loss Characteristics and Permittivity \(Dielectric Constant\) of Solid Electrical Insulation](#)
- [D257 Test Methods for DC Resistance or Conductance of Insulating Materials](#)
- [D374 Test Methods for Thickness of Solid Electrical Insulation \(Metric\) D0374\\_D0374M](#)
- [D412 Test Methods for Vulcanized Rubber and Thermoplastic Elastomers—Tension](#)
- [D471 Test Method for Rubber Property—Effect of Liquids](#)
- [D543 Practices for Evaluating the Resistance of Plastics to Chemical Reagents](#)
- [D638 Test Method for Tensile Properties of Plastics](#)
- [D1711 Terminology Relating to Electrical Insulation](#)
- [D1868 Test Method for Detection and Measurement of Partial Discharge \(Corona\) Pulses in Evaluation of Insulation Systems](#)
- [D2303 Test Methods for Liquid-Contaminant, Inclined-Plane Tracking and Erosion of Insulating Materials](#)
- [D2307 Test Method for Thermal Endurance of Film-Insulated Round Magnet Wire](#)
- [D2865 Practice for Calibration of Standards and Equipment for Electrical Insulating Materials Testing](#)
- [D3183 Practice for Rubber—Preparation of Pieces for Test Purposes from Products](#)
- [D3636 Practice for Sampling and Judging Quality of Solid Electrical Insulating Materials](#)
- [D3638 Test Method for Comparative Tracking Index of Electrical Insulating Materials](#)
- [D5032 Practice for Maintaining Constant Relative Humidity by Means of Aqueous Glycerin Solutions](#)
- [D5374 Test Methods for Forced-Convection Laboratory Ovens for Evaluation of Electrical Insulation](#)

<sup>2</sup> For referenced ASTM standards, visit the ASTM website, [www.astm.org](http://www.astm.org), or contact ASTM Customer Service at [service@astm.org](mailto:service@astm.org). For *Annual Book of ASTM Standards* volume information, refer to the standard's Document Summary page on the ASTM website.

[D5423 Specification for Forced-Convection Laboratory Ovens for Evaluation of Electrical Insulation](#)  
[D6054 Practice for Conditioning Electrical Insulating Materials for Testing \(Withdrawn 2012\)<sup>3</sup>](#)  
[D8354 Test Method for Flammability of Electrical Insulating Materials Intended for Wires or Cables When Burning in a Vertical Configuration](#)  
[E29 Practice for Using Significant Digits in Test Data to Determine Conformance with Specifications](#)  
[E691 Practice for Conducting an Interlaboratory Study to Determine the Precision of a Test Method](#)

2.2 *IEEE Standards:*<sup>4</sup>

[IEEE 98 Guide for the Preparation of Test Procedures for the Thermal Evaluation of Electrical Insulating Materials](#)  
[IEEE 101 Statistical Analysis of Thermal Life Test Data](#)

2.3 *Federal Standard:*<sup>5</sup>

[PPP-T-45C Federal Specification for Tape, Gummed; Paper, Reinforced and Plain, for Sealing and Securing \(PPP-T-45C\)](#)

### 3. Terminology

#### 3.1 Definitions:

3.1.1 For definitions of terms used in these test methods, refer to Terminology [D1711](#).

#### 3.2 Definitions of Terms Specific to This Standard:

3.2.1 *capacitance unbalance (of a pair in a shielded cable), n*—the ratio, expressed as a percentage, of the difference in capacitance between each of two insulated conductors and the shield, to the capacitance between that conductor pair.

##### 3.2.1.1 Discussion—

Capacitance unbalance is also called coefficient of asymmetry or capacitance asymmetry, and is expressed in percent unbalance.

3.2.2 *cold bend test*—a test in which a specimen is slowly wrapped around a mandrel of a specified diameter after conditioning at a specified low temperature to determine that the primary insulation, primary jacket, overall jacket and any other layer of the wire or cable specimen maintains sufficient flexibility to withstand such bending at that low temperature without evidence of cracking.

3.2.3 *relative thermal endurance*—the comparison of the thermal endurance (as described by their Arrhenius plots) of two or more insulated wires designed for the same specific use; this usually implies the same size of conductor, but the insulation is of the thickness required for the particular use of each insulation.

3.2.4 *strip force*—force required to remove a specified length of insulation from an insulated wire specimen as determined by a specified test procedure.

3.2.5 *surface resistance, n*—see Terminology [D1711](#).

##### 3.2.5.1 Discussion—

For a fixed electrode separation, the measured surface resistance of a given hookup wire decreases as the diameter increases.

3.2.6 *temperature index, n*—see Terminology [D1711](#).

##### 3.2.6.1 Discussion—

For hookup wire, the symbol TI is used for temperature index and the preferred use of the TI symbol implies a time of 20 000 h obtained by analysis of aging data in which extrapolation is limited to no more than 25 °C below the lowest aging temperature. (See also Section [14.13](#).)

3.2.7 *thermal end point curve, n*—a graphical representation of a thermal end point at a specified aging temperature in which the value of a property of a material, or a simple combination of materials, is measured at room temperature and the values plotted as a function of time.

3.2.8 *thermal end point time, n*—the time necessary for a specific property of a material, or a simple combination of materials, to degrade to a defined end point when aged at a specified temperature.

<sup>3</sup> The last approved version of this historical standard is referenced on [www.astm.org](http://www.astm.org).

<sup>4</sup> Available from Institute of Electrical and Electronics Engineers, Inc. (IEEE), 445 Hoes Ln., Piscataway, NJ 08854-4141, <http://www.ieee.org>.

<sup>5</sup> Available from Standardization Documents Order Desk, Bldg. 4 Section D, 700 Robbins Ave., Philadelphia, PA 19111-5094, Attn: NPODS.

3.2.9 *thermal endurance, n*—see Terminology **D1711**.

3.2.9.1 *Discussion*—

The stability of hookup wire insulation is estimated from changes in the results of voltage withstand tests on hookup wire specimens that have been heat aged, cooled to room temperature, flexed over a mandrel, immersed in salt water, and subjected to a specific applied voltage.

3.2.10 *voltage withstand (proof-voltage) test*—the application of a specified voltage for a specified time to a specified configuration of the insulation. Results are expressed as “pass” or “fail.”

#### **4. Sampling**

4.1 Refer to the material specification for sampling plan covering specific types of hookup wire insulations.

4.2 Use Practice **D3636** as a guide if the material specification does not include a sampling plan.

**iTeh Standards**  
**(<https://standards.itih.ai>)**  
**Document Preview**

[ASTM D3032-21a](#)

<https://standards.itih.ai/catalog/standards/sist/fc19864f-ee5f-45a9-802e-31b7216ed199/astm-d3032-21a>

## 5. Dielectric Breakdown Voltage

### 5.1 Significance and Use:

5.1.1 A detailed statement of significance is given in **Appendix X1** of Test Method **D149**.

### 5.2 Apparatus:

5.2.1 Use the electrical apparatus described in Test Method **D149** for this ~~test~~test method.

### 5.3 Test Specimens:

5.3.1 The test specimen shall consist of insulated wire 610 mm (24 in.) in length, or of the length required for the environmental exposure. Remove the insulation for a distance of 25 mm (1 in.) at each end and twist the ends together.

### 5.4 Procedure:

5.4.1 Immerse the test specimen to within 152 mm (6 in.) of the twisted ends in the water bath containing 5 % sodium chloride (NaCl) and 0.05 to 0.10 % wetting agent.

NOTE 1—Triton X-100<sup>6,7</sup> has been found satisfactory for this test method.

5.4.2 Use the water solution as the ground electrode, and apply the voltage to the twisted end of the conductor.

5.4.3 Raise the voltage from zero at a rate of 500 V/s until the specimen fails. If a flashover between the water solution and the twisted ends of the wire occurs, discard the specimen without retesting. Select longer specimens so that the distance between the water solution and the ends of the wire is sufficient to prevent flashover.

### 5.5 Report:

5.5.1 Report the following information:

5.5.1.1 Description of the specimen, <http://www.astm.org/standards/sist/fc19864f-ee5f-45a9-802e-31b7216ed199/astm-d3032-21a>

5.5.1.2 Voltage at which breakdown occurred,

5.5.1.3 Description of any previous environmental exposure given to the specimen before testing, and

5.5.1.4 Conditions under which the test was run.

## 6. Insulation Resistance

### 6.1 Significance and Use:

6.1.1 In high impedance circuits, insulation resistance is functionally important. In some cases, changes in insulation resistance indicates deterioration of other properties. Insulation resistance is also useful for quality control.

NOTE 2—The term “insulation resistance” is a standard term used in the hookup wire industry to designate the resistance of a specified length of insulated wire, normally expressed as  $\Omega$ -1000 ft. This is not a true insulation resistance since a resistance for a known length can be calculated and, also, the tests are conducted in a manner to eliminate surface conduction. The value obtained in this type of measurement is actually a volume resistance, but will be referred to here as insulation resistance to avoid confusion in the hookup wire industry.

<sup>6</sup> Triton X-100 is a trademark of The Dow Chemical Company, Midlands, Michigan, <http://www.dow.com>.

<sup>7</sup> Triton X-100 is a trademark of The Dow Chemical Company, Midlands, Michigan, <http://www.dow.com>. The sole source of supply of the apparatus Triton X-100 known to the committee at this time is The Dow Chemical Company. If you are aware of alternative suppliers, please provide this information to ASTM International Headquarters. Your comments will receive careful consideration at a meeting of the responsible technical committee,<sup>1</sup> which you may attend.

## 6.2 Apparatus:

6.2.1 *Battery Jar*, or other insulated vessel, large enough to immerse the specimen, filled with water containing 0.05 to 0.10 % wetting agent.<sup>7</sup> The water bath shall serve as one electrode.

6.2.2 Use apparatus described in Test Methods **D257** for the resistance measurement.

## 6.3 Test Specimens:

6.3.1 The test specimen shall consist of a 8.3 m (or 26-ft) length of the insulated wire. Remove the insulation for a distance of 25 mm (1 in.) at each end and twist the ends together.

## 6.4 Procedure:

6.4.1 Immerse the specimen to within 152 mm (6 in.) of the twisted ends in the water bath, which is maintained at  $23 \pm 5$  °C ( $73 \pm 9$  °F). Make an initial resistance measurement between the conductor and the water bath for the purpose of detecting nontypical values. Discard any specimen with a gross defect (that is, having an insulation resistance less than  $1 \times 10^6$  Ω between the conductor and the water bath) and replace it with another specimen.

6.4.2 After 4 h, remeasure the resistance between the conductor and the water bath. Make the measurement at 500 ( $\pm 10$  %) d-c V, after an electrification time of 1 min, unless otherwise specified.

## 6.5 Calculation:

6.5.1 Calculate the insulation resistance as Ω-1000 ft as follows:

$$\text{insulation resistance, } \Omega - 1000 \text{ ft} = (R \times L)/1000 \quad (1)$$

where:

$R$  = measured resistance, Ω, and

$L$  = immersed length, 25 ft.

6.5.2 Calculate the insulation resistance as Ω-1000 m as follows:

$$\text{insulation resistance, } \Omega - 1000 \text{ m} = (R \times L)/1000 \quad (2)$$

where:

$L'$  = immersed length, 8 m.

NOTE 3—Do not express insulation resistance as Ω·m since this unit describes resistivity. It must be used as Ω for some unit of length.

## 6.6 Report:

6.6.1 Report the following information:

6.6.1.1 Description of the specimen,

6.6.1.2 Immersed length of the specimen,

6.6.1.3 Applied voltage,

6.6.1.4 Time of electrification,

6.6.1.5 Immersion time,

6.6.1.6 Measured resistance,

6.6.1.7 The insulation resistance of the specimen calculated in  $\Omega$  -1000 ft (or in  $\Omega$ -1000 m), and

6.6.1.8 Number of specimens discarded.

## 7. Surface Resistance

### 7.1 Significance and Use:

7.1.1 At high humidities, surface conduction is responsible for the largest part of the leakage current in service (for example, at the terminations of bundled hookup wires).

7.1.2 Additional statements on the significance of surface resistance can be found are contained in Test Methods **D257**.

### 7.2 Apparatus:

7.2.1 Test Chamber—~~A suitable test chamber can be made from a vessel fitted with a cover through which leads have been sealed. The leads can be made from sealed will provide a suitable test chamber. An appropriate material for the leads is polytetrafluoroethylene (PTFE)-insulated wire, sealed with paraffin wax or silicone grease as they pass through the cover. The use of PTFE-insulated feed-through bushings can also be used in place of the wires is acceptable~~ (Fig. 1).

7.2.2 As an alternative method, it is acceptable to use a paraffin wax collar ~~can be fitted to the top of a glass vessel and tin-coated size 1.02 mm (AWG No. 18) solid copper wires can be~~ wires, which are sealed through the paraffin wax. A glass cover can then be used is appropriate to seal the top of the test chamber (Fig. 2).

7.2.3 Use the test instruments described in Test Methods **D257** for the resistance measurement.

7.2.4 The electrical resistance of the chamber, measured between the lead wires under the conditions given in 7.3 with no specimens in place, shall be greater than  $10^{12} \Omega$ .

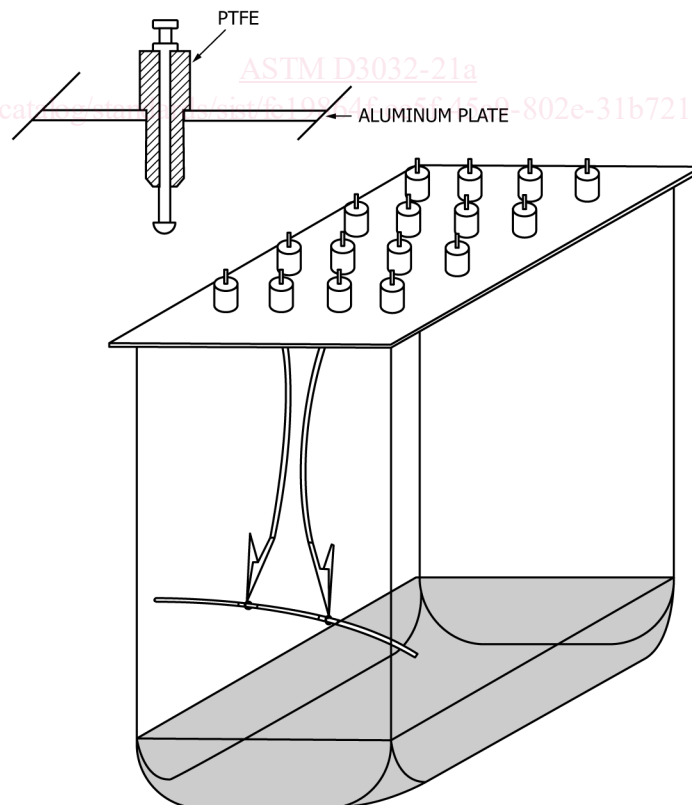

FIG. 1 Typical Surface Resistance Test Chamber Using Feed-through Bushings

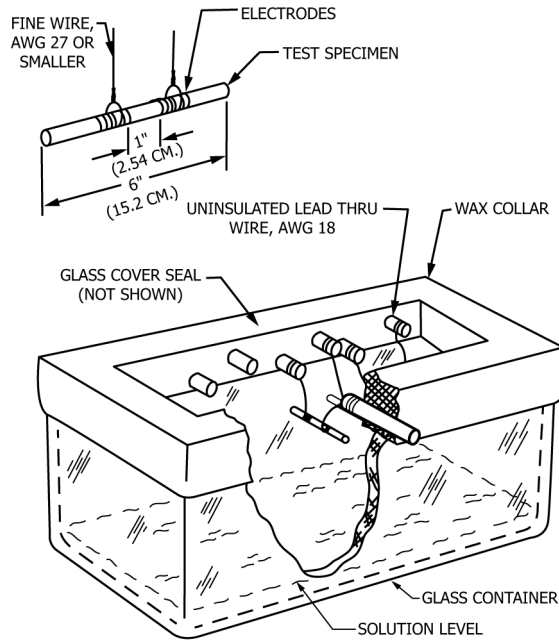

FIG. 2 Typical Surface Resistance Test Chamber Using Paraffin Wax Collar

### 7.3 Test Specimens:

#### 7.3.1 Measure five specimens.

7.3.2 The specimens shall consist of 152 mm (6-in.) lengths of finished wire, cleaned in accordance with the procedure recommended by the manufacturer. Handle the specimens subsequently with maximum care, preferably with clean lint-free gloves to avoid even the slightest contamination, including direct contact with the fingers. Provide each cleaned specimen near its center with two electrodes spaced  $25.4 \pm 0.1$  mm ( $1.0 \pm 0.005$  in.) ( $1.0 \pm 0.005$  in.) apart between their nearest edges. Each electrode shall be approximately 13 mm ( $\frac{1}{2}$  in.) wide, and shall consist of conductive silver paint painted around the circumference of the specimen. Make electrical connection to the dry electrodes by wrapping several turns of fine tin-coated copper wire (0.361 mm (AWG No. 27) or finer) around the electrode, leaving a free end of the fine wire of sufficient length for connecting to the electrical lead wires inside the test chamber.



#### 7.4 *Conditioning:*

7.4.1 Measure the surface resistance after an exposure time of 96 h before removing the specimens from the test chamber.

7.4.2 Maintain the conditions in the test chamber within  $\pm 2$  °C of a temperature selected in the range from 18 to 27 °C, and within  $\pm 2$  % relative humidity of a relative humidity selected in the range from 90 to 96 % relative humidity.

7.4.3 ~~The~~ Maintain the relative humidity ~~can be maintained~~ over an aqueous glycerin solution described in Practice **D5032**.

NOTE 4—The allowable temperature variation for a given solution must be kept within the necessary range to maintain the relative humidity in the chamber to the required limits.

#### 7.5 *Procedure:*

7.5.1 After the conditioning period stated in **7.3**, measure the resistance between the electrodes after an electrification time of 1 min at 500 ( $\pm 10$  %) dc V.

NOTE 5—In some test methods the measured resistance is multiplied by the outside diameter of the insulation. ~~The~~ It is important that the values so calculated ~~should~~ not be confused with the measured values nor with the true surface resistivity of the specimen.

#### 7.6 *Report:*

7.6.1 Report the following information:

7.6.1.1 Description of the specimen,

7.6.1.2 Diameter of the specimen,

7.6.1.3 Test conditions (temperature and relative humidity),

7.6.1.4 Applied voltage, and

7.6.1.5 Measured surface resistance.

### 8. Voltage Withstand Test

#### 8.1 *Significance and Use:*

8.1.1 This test method is useful as a screening test for eliminating specimens unsuitable for further testing. ~~It can also be used~~ also an acceptable method to determine whether exposure to environmental test conditions has reduced the breakdown strength below some prescribed level.

#### 8.2 *Apparatus:*

8.2.1 Use the electrical apparatus described in Test Method **D149** for this ~~test~~ test method.

8.2.2 *Water Bath*, containing 5 % sodium chloride (NaCl) and 0.5 to 0.10 % wetting agent.<sup>7</sup>

8.2.3 The sensitivity of the test equipment shall be such that a fault is indicated when one half of the specified test voltage is applied to the conductor of a length of 0.644 mm (AWG No. 22) stranded insulated wire whose other end, with the insulation cut flush with the conductor, is inserted 6.4 mm (1/4 in.) into the test solution as far from the ground electrode as the specimen to be tested. Add more NaCl, if necessary, to the solution to meet these conditions. Fault-indicating equipment is described in Test Method **D149**.

#### 8.3 *Test Specimens:*

8.3.1 The test specimen shall consist of insulated wire 610 mm (24 in.) in length, or of the length required for environmental exposure. Remove the insulation for a distance of 25 mm (1 in.) at each end and twist the ends together.

8.3.2 Replace any specimen having an initial gross flaw (that is, having an insulation-resistance less than  $1 \times 10^6 \Omega$  between the conductor and the solution) before exposure to environmental conditioning.

#### 8.4 Procedure:

8.4.1 Immerse the test specimen to within 51 mm (2 in.) of the twisted ends in the water solution described in 8.2.2.

8.4.2 Measure the resistance between the conductor and the water solution at 500 ( $\pm 10\%$ ) dc V to detect gross flaws (8.3.2). Use the apparatus described in Test Methods D257 for the resistance measurement.

NOTE 6—This screening test is performed before environmental exposure and is not repeated after the exposure.

8.4.3 After a 4-h soak, apply the voltage between the twisted ends of the conductor and the grounded water, increasing from zero to the specified value at a rate of 500 V/s. Hold the voltage on the specimen for 1 min, or for the time required in the applicable specification.

#### 8.5 Report:

8.5.1 Report the following information:

8.5.1.1 Description of the specimen,

8.5.1.2 Electrification time and voltage,

8.5.1.3 Description of the environmental exposure given the specimen before test,

8.5.1.4 Whether or not the specimen withstood the required voltage for the specified time,

8.5.1.5 Time for failure in case failure occurs, and

8.5.1.6 Number of specimens discarded.

### 9. Capacitance of Shielded, Single-conductor Hookup Cable

#### 9.1 Significance and Use:

9.1.1 Capacitance per unit length is useful for quality control and is sometimes required for electronic circuit design purposes.

9.1.2 Additional statements on the significance of capacitance can be are found in Test Methods D150.

#### 9.2 Apparatus:

9.2.1 Use the apparatus described in Test Methods D150 for this test method.

#### 9.3 Test Specimens:

9.3.1 The specimen shall consist of a piece of shielded hookup cable approximately 3 m (10 ft) in length.

9.3.2 Remove the jacket, if any, for a distance of 25 mm (1 in.) from one end of the specimen and unbraid the shield for this distance. Remove the insulation from the conductor for a distance of 13 mm ( $\frac{1}{2}$  in.). Twist the unbraid shield conductors together for connection to the measuring instrument and to prevent slippage of the shield on the insulation. A piece of tape over the shield ~~can also be used~~ is an appropriate means to prevent slippage.

9.3.3 Terminate the opposite end of the specimen by cutting all parts of the specimen flush and perpendicular to the axis. Take care to maintain concentricity of the specimen where it is cut. Use tape around the shield of an unjacketed specimen to prevent slippage as long as the tape does not come in contact with the insulation or the conductor.

9.3.4 As an alternative method, prepare both ends of the specimen ~~can be prepared~~ in accordance with 9.3.2. When this is done, twist the conductors from both ends of the specimen together for connection to the measuring instrument. ~~The shields can~~ It is acceptable for the shields to also be twisted together.

9.3.5 Use the distance in which the shield is in contact with the insulation as the effective length of the specimen.

#### 9.4 Procedure:

9.4.1 Connect the specimen to the measuring instrument and measure the capacitance. Subtract the capacitance of the terminals from the measured capacitance value (Note 7).

NOTE 7—Detailed instructions for making the measurements needed to obtain the capacitance and for making any necessary corrections due to the measuring circuit are given in the instruction books supplied with commercial equipment.

#### 9.5 Report:

9.5.1 Report the following information:

9.5.1.1 Description of the specimen,

9.5.1.2 Effective length of the specimen,

9.5.1.3 Frequency at which the measurement was made,

9.5.1.4 Temperature and relative humidity at which the measurement was made,

9.5.1.5 Measured capacitance, and

9.5.1.6 Capacitance of the specimen calculated in capacitance per ft (picofarad per ft) or capacitance per m (picofarad per m).

### 10. Capacitance and Capacitance Unbalance of Shielded Two-conductor Hookup Cable

#### 10.1 Significance and Use:

10.1.1 Capacitance per unit length and capacitance unbalance are useful for quality control, and sometimes required for electronic circuit design purposes.

#### 10.2 Apparatus:

10.2.1 Use the electrical apparatus described in Test Methods D150 for this test method.

#### 10.3 Test Specimens:

10.3.1 Prepare the specimen in accordance with 9.3, except that the insulation at one end shall be removed from both conductors for a distance of 13 mm ( $\frac{1}{2}$  in.).

#### 10.4 Procedure:

10.4.1 Designate one conductor as No. 1, the other conductor as No. 2, and the shield as No. 3.

10.4.2 The shield will be connected to one terminal of the measuring instrument for all three measurements needed to determine the capacitance of this type of specimen.

10.4.3 Measure the capacitance between conductor No. 2 at one terminal of the measuring instrument and No. 1 and No. 3 at the other terminal (**Note 7**). This capacitance value is  $C_a$ .

10.4.4 Measure the capacitance between conductor No. 1 at one terminal and No. 2 and No. 3 at the other terminal. This capacitance value is  $C_b$ .

10.4.5 Measure the capacitance between conductors No. 1 and No. 2 at one terminal and No. 3 at the other terminal. This value of capacitance is  $C_c$ .

10.4.6 Measure the length of lay of the twisted pair after the shield has been removed. The lay of the helically wound insulated conductors is the axial length of one turn of the helix.

#### 10.5 Calculation:

10.5.1 Calculate the capacitance between the two conductors,  $C$ , as follows:

$$C = [(2(C_a + C_b) - C_c)/4] - [(C_a - C_b)^2/4 C_c] \quad (3)$$

**NOTE 8**—The second term of this equation is frequently neglected when the difference between  $C_a$  and  $C_b$  is small.

10.5.2 Calculate the percent capacitance unbalance as follows:

$$\text{capacitance unbalance, \%} = [(C_a - C_b)/C] \times 100 \quad (4)$$

#### 10.6 Report:

10.6.1 Report the following information:

10.6.1.1 Description of the specimen,

10.6.1.2 Effective length of the specimen,

10.6.1.3 Frequency at which the measurements were made,

10.6.1.4 Temperature and relative humidity at which the measurements were made,

10.6.1.5 Capacitance measured in **10.4.3**,  $C_a$ ,

10.6.1.6 Capacitance measured in **10.4.4**,  $C_b$ ,

10.6.1.7 Capacitance measured in **10.4.5**,  $C_c$ ,

10.6.1.8 Capacitance calculated in **10.5.1**,

10.6.1.9 Capacitance between the two conductors, picofarad per ft (capacitance per ft) or picofarad per m (capacitance per m),

10.6.1.10 Length of lay of the twisted pair after the shield has been removed in metres or inches, and

**NOTE 9**—Lay is sometimes expressed in twists per m or twists per ft.

10.6.1.11 Capacitance unbalance calculated in **10.5.2**.

### 11. Capacitance of Unshielded Twisted Pair Hookup Wire

#### 11.1 Significance and Use:

11.1.1 Capacitance per unit length is useful for quality control and is sometimes required for electronic circuit design purposes.

11.2 Apparatus:

11.2.1 Use the electrical apparatus described in Test Methods D150 for this test method.

11.3 Test Specimens:

11.3.1 The specimen shall consist of a piece of twisted pair hookup wire approximately 3 m (10 ft) in length.

11.3.2 Remove the jacket, if any, for a distance of 25 mm (1 in.), or tape the wires together 1 in. back from one end of the twisted pair. Remove 13 mm (½ in.) of the insulation from both conductors.

11.3.3 If the sample is not jacketed, tape the other end of the specimen to prevent the wires from untwisting during measurement.

11.3.4 The length that the two wires are in contact will be used as the effective specimen length (Fig. 3).

11.4 Procedure:

11.4.1 Suspend the uncoiled specimen at least 0.9 m (3 ft) away from possible ground planes, such as work benches, table tops, floors, etc. ~~Any Use any insulating material can be used to hang the specimen in the appropriate position.~~

11.4.2 Connect the specimen to the measuring instrument and measure the capacitance. Subtract the capacitance of the terminals from the measured capacitance value (Note 6).

11.4.3 Measure the length of lay of the twisted pair. The lay of the helically wound insulated conductor is the axial length of one turn of the helix.

NOTE 10—The capacitance of twisted pair hookup wire is dependent on the length of lay. Higher capacitance values will be obtained on specimens of the same material with shorter lengths of lay.

11.5 Report:

11.5.1 Report the following information:

11.5.1.1 Description of the specimen,

11.5.1.2 Effective length of the specimen,

11.5.1.3 Frequency at which the measurements were made,

11.5.1.4 Temperature and relative humidity at which the measurements were made,

11.5.1.5 Measured capacitance,

11.5.1.6 Capacitance of the specimen calculated, picofarads per ft (capacitance per ft) or picofarads per m (capacitance per m), and

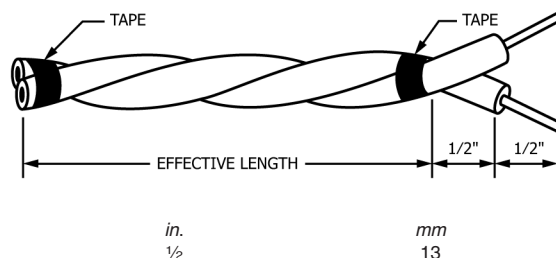

FIG. 3 Effective Specimen Length

11.5.1.7 Length of lay of the twisted pair in inches or metres (Note 10).

## ~~12. Capacitance and Dissipation Factor of Hookup Wire Insulation by Mercury U-Tube Method~~

### ~~12.1 Significance and Use:~~

~~12.1.1 Capacitance per unit length and dissipation factor are useful for quality control and are sometimes required for electronic circuit design purposes. The capacitance is also needed to calculate the permittivity (dielectric constant) of an insulating material.~~

~~12.1.2 Additional statements on the significance of capacitance and dissipation factor can be found in Test Methods D150.~~

### ~~12.2 Apparatus:~~

~~12.2.1 A suitable mercury U-tube electrode, as shown in Fig. 4. (Warning—Mercury metal vapor poisoning has long been recognized as a hazard in industry. The maximum exposure limits are set by the American Conference of Governmental Industrial Hygienist.<sup>7</sup> The concentration of mercury vapor over spills from broken thermometers, barometers, or other instruments using mercury can easily exceed these exposure limits. Mercury, being a liquid and quite heavy, will disintegrate into small droplets and seep into cracks and crevices in the floor. The use of a commercially available emergency spill kit is recommended whenever a spill occurs. The increased area of exposure adds significantly to the mercury vapor concentration in the air. Mercury vapor concentration is easily monitored using commercially available sniffers. Spot checks should be made periodically around operations where mercury is exposed to the atmosphere. Thorough checks should be made after spills.)~~

~~12.2.2 Use apparatus described in Test Methods D150.~~

### ~~12.3 Reagents:~~

~~12.3.1 Hydrochloric Acid (5+5):~~

~~12.3.2 Sodium Carbonate Solution:~~

### ~~12.4 Preparation of Apparatus:~~

~~12.4.1 Cleaning the U-Tube—To assure low resistance contact between the steel U-tube and the mercury, clean the U-tube using the procedure given in 12.4.1.1 – 12.4.1.6, as follows:~~

~~12.4.1.1 Degrease the U-tube with toluene.~~

~~12.4.1.2 Wash with cleanser and brush.~~

~~12.4.1.3 Rinse with water.~~

~~12.4.1.4 Etch for 15 min with HCl (5+5):~~

~~12.4.1.5 Neutralize with Na<sub>2</sub>CO<sub>3</sub> solution.~~

~~12.4.1.6 Rinse with hot distilled water.~~

~~12.4.1.7 Fill with mercury as soon as possible after 12.4.1.6.~~

~~12.4.1.8 There is a health hazard present due to the toxicity of mercury vapor (see 12.2.1). Take suitable precautions during use. Cap the ends of the U-tube when they are not in use. Take care to remove and appropriately dispose of mercury that adheres to the wire as it is removed from test.~~

### ~~12.5 Calibration of U-Tube:~~

~~12.5.1 Determine the length of the mercury in the U-tube by passing a small diameter wire or thin plastic line, that has been suitably marked off for length, through the U-tube.~~

~~12.5.2 Mark off one of the glass tubes on the top of the U-tube in 6 mm (¼-in.) intervals from the mercury fill line so that the length of specimens of different diameters can be measured.~~

#### ~~12.6 Test Specimens:~~

~~12.6.1 The specimen shall consist of a piece of hookup wire of sufficient length to pass through the mercury U-tube and permit joining the ends together.~~

#### ~~12.7 Procedure:~~

~~12.7.1 Cap off one end of the specimen to prevent mercury from entering the conductor when it is inserted in the U-tube.~~

~~12.7.2 Insert the specimen in the U-tube.~~

~~NOTE 11—A thin plastic line has been found useful for pulling the specimen through the mercury U-tube. The line is reinserted as the specimen is removed.~~

~~12.7.3 Remove the insulation for a distance of 25 mm (1 in.) from each end of the specimen and twist the free ends of the conductor together.~~

~~12.7.4 Connect the measuring instrument between the twisted ends of the specimen and the copper wire frame soldered to the U-tube.~~

~~12.7.5 Measure the capacitance and dissipation factor of the specimen (see Note 6).~~

~~12.7.6 Record the effective length (the length of the specimen in contact with the mercury) of the specimen obtained from the marks on the U-tube (see 12.4).~~

#### ~~12.8 Report:~~

~~12.8.1 Report the following information:~~

~~12.8.1.1 Description of the specimen;~~

~~12.8.1.2 Effective length of the specimen;~~

~~12.8.1.3 Frequency at which the measurement was made;~~

~~12.8.1.4 Temperature and relative humidity at which the measurement was made;~~

~~12.8.1.5 Measured capacitance;~~

~~12.8.1.6 Capacitance of the specimen calculated in picofarad per m or picofarad per ft;~~

~~12.8.1.7 Dissipation factor of the specimen, and~~

~~12.8.1.8 Date, laboratory, and person making the measurement.~~

## **12. Insulation-continuity Proof Tests**

### **12.1 Scope:**

12.1.1 Insulation-continuity of hookup wire is tested by one of the following methods: