



Designation: E426 – 16 (Reapproved 2021)

Standard Practice for Electromagnetic (Eddy Current) Examination of Seamless and Welded Tubular Products, Titanium, Austenitic Stainless Steel and Similar Alloys¹

This standard is issued under the fixed designation E426; the number immediately following the designation indicates the year of original adoption or, in the case of revision, the year of last revision. A number in parentheses indicates the year of last reapproval. A superscript epsilon (ϵ) indicates an editorial change since the last revision or reapproval.

This standard has been approved for use by agencies of the U.S. Department of Defense.

1. Scope*

1.1 This practice² covers procedures for eddy current examination of seamless and welded tubular products made of relatively low conductivity materials such as titanium, stainless steel, and similar alloys, such as nickel alloys. Austenitic chromium-nickel stainless steels, which are generally considered to be nonmagnetic, are specifically covered as distinguished from the martensitic and ferritic straight chromium stainless steels which are magnetic.

1.2 This practice is intended as a guide for eddy current examination of both seamless and welded tubular products using either an encircling coil or a probe-coil technique. Coils and probes are available that can be used inside the tubular product; however, their use is not specifically covered in this document. This type of examination is usually employed only to examine tubing which has been installed such as in a heat exchanger.

1.3 This practice covers the examination of tubular products ranging in diameter from 0.125 to 5 in. (3.2 to 127.0 mm) and wall thicknesses from 0.005 to 0.250 in. (0.127 to 6.4 mm).

1.4 For examination of aluminum alloy tubular products, see standard Practice E215.

1.5 *Units*—The values stated in inch-pound units are to be regarded as standard. The values given in parentheses are mathematical conversions to SI units that are provided for information only and are not considered standard.

1.6 *This standard does not purport to address all of the safety concerns, if any, associated with its use. It is the responsibility of the user of this standard to establish appropriate*

¹ This practice is under the jurisdiction of ASTM Committee E07 on Nondestructive Testing and is the direct responsibility of Subcommittee E07.07 on Electromagnetic Method.

Current edition approved June 1, 2021. Published June 2021. Originally approved in 1971. Last previous edition approved in 2016 as E426 – 16. DOI: 10.1520/E0426-16R21.

² For ASME Boiler and Pressure Vessel Code applications see related Practice SE-426 in Section II of that Code.

appropriate safety, health, and environmental practices and determine the applicability of regulatory limitations prior to use.

1.7 *This international standard was developed in accordance with internationally recognized principles on standardization established in the Decision on Principles for the Development of International Standards, Guides and Recommendations issued by the World Trade Organization Technical Barriers to Trade (TBT) Committee.*

2. Referenced Documents

2.1 ASTM Standards:³

- E215 Practice for Standardizing Equipment and Electromagnetic Examination of Seamless Aluminum-Alloy Tube
- E543 Specification for Agencies Performing Nondestructive Testing
- E1316 Terminology for Nondestructive Examinations

2.2 Other Documents:

- SNT-TC-1A Recommended Practice for Personnel Qualification and Certification in Nondestructive Testing⁴
- ANSI/ASNT CP-189 ASNT Standard for Qualification and Certification of Nondestructive Testing Personnel⁴
- NAS-410 NAS Certification and Qualification of Nondestructive Personnel (Quality Assurance Committee)⁵
- ISO 9712 Non-Destructive Testing—Certification and Qualification of NDT Personnel⁶

3. Terminology

3.1 Standard terminology relating to electromagnetic testing may be found in Terminology E1316, Section C, Electromagnetic Testing.

³ For referenced ASTM standards, visit the ASTM website, www.astm.org, or contact ASTM Customer Service at service@astm.org. For *Annual Book of ASTM Standards* volume information, refer to the standard's Document Summary page on the ASTM website.

⁴ Available from American Society for Nondestructive Testing (ASNT), P.O. Box 28518, 1711 Arlington Ln., Columbus, OH 43228-0518, <http://www.asnt.org>.

⁵ Available from Aerospace Industries Association of America, Inc. (AIA), 1000 Wilson Blvd., Suite 1700, Arlington, VA 22209-3928, <http://www.aia-aerospace.org>.

⁶ Available from International Organization for Standardization (ISO), ISO Central Secretariat, BIBC II, Chemin de Blandonnet 8, CP 401, 1214 Vernier, Geneva, Switzerland, <http://www.iso.org>.

*A Summary of Changes section appears at the end of this standard

4. Summary of Practice

4.1 The examination is conducted using one of two general techniques shown in Fig. 1. One of these techniques employs one or more exciter and sensor coils which encircle the pipe or tube and through which the tubular product to be examined is passed. Some circuit configurations employ separate exciter and sensor coils; whereas other configurations employ one or more coils that concurrently function as both exciters and sensors. Alternating current passes through the exciting coil which by reason of its proximity induces current in the tubular product. The sensor coil detects the resultant electromagnetic flux related to these currents. The presence of discontinuities in the tubular product will affect the normal flow of currents and this change is detected by the sensor. The encircling coil technique is capable of examining the entire 360-deg expanse of the tubular product.

4.2 Another technique employs a probe coil with one or more exciters and sensors which is brought in close proximity of the surface of the tubular product to be examined. Since the probe is generally small and does not encircle the article being examined, it examines only a limited area in the vicinity of the probe. If it is desired to examine the entire volume of the tubular product, it is common practice to either rotate the tubular product or the probe. In the case of welded tubular

products frequently only the weld is examined by scanning along the weld zone. In the case where the tubular products are joined by welding and the probe is rotated, the probe is orbited about the central axis of the tube such that a circumferential examination of the tube and/or weld may be made. The depth of penetration of the interrogating magnetic fields into the tubular product may be smaller for this type of probe coil compared to the encircling coil.

5. Significance and Use

5.1 Eddy current testing is a nondestructive method of locating discontinuities in a product. Changes in electromagnetic response caused by the presence of discontinuities are detected by the sensor, amplified and modified in order to actuate audio or visual indicating devices, or both, or a mechanical marker. Signals can be caused by outer surface, inner surface, or subsurface discontinuities. The eddy current examination is sensitive to many factors that occur as a result of processing (such as variations in conductivity, chemical composition, permeability, and geometry) as well as other factors not related to the tubing. Thus, all received indications are not necessarily indicative of defective tubing.

6. Basis of Application

6.1 If specified in the contractual agreement, personnel performing examinations to this practice shall be qualified in accordance with a nationally recognized NDT personnel qualification practice or standard such as ANSI/ASNT-CP-189, SNT-TC-1A, NAS-410, ASNT-ACCP, ISO 9712, or a similar document and certified by the certifying agency, as applicable. The practice or standard used and its applicable revision shall be identified in the contractual agreement between the using parties.

NOTE 1—MIL-STD-410 is canceled and has been replaced with NAS-410, however, it may be used with agreement between contracting parties.

6.2 If specified in the contractual agreement, NDT agencies shall be qualified and evaluated in accordance with Specification E543. The applicable edition of Specification E543 shall be specified in the contractual agreement.

7. Apparatus

7.1 *Electronic Apparatus*—The electronic apparatus shall be capable of energizing the examination coils or probes with alternating currents of suitable frequencies and shall be capable of sensing the changes in the electromagnetic response of the sensors. Equipment may include a detector, phase discriminator, filter circuits, modulation circuits, magnetic-saturation devices, recorders, and signaling devices as required for the particular application.

7.2 *Examination Coils*—Examination coils shall be capable of inducing current in the tube and sensing changes in the electrical characteristics of the tube.

NOTE 2—Fill factor effect is an important consideration since coupling variations can affect the examination significantly.

7.3 *Probe Coils*—Probe coils shall be capable of inducing current in the tube and sensing changes in the electrical characteristics of the tube (Note 3). Probes generally consist of

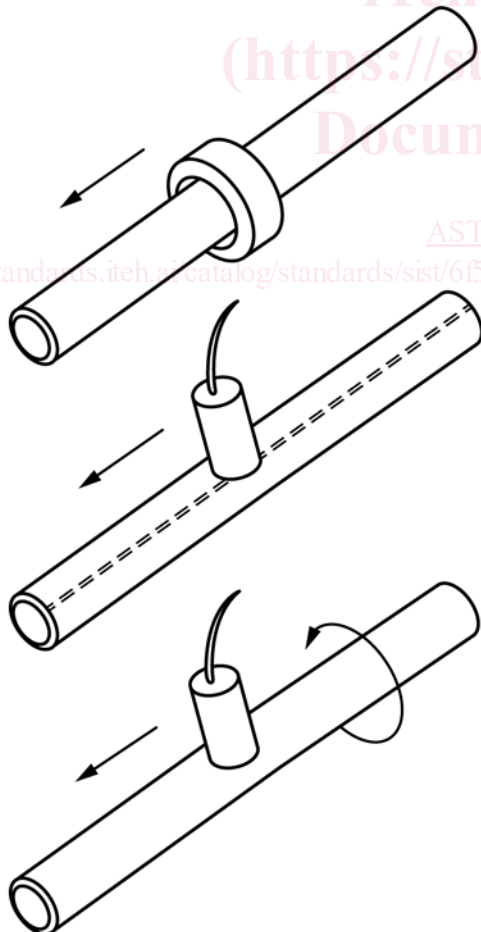

FIG. 1 Sketch Showing Encircling-Coil and Probe-Coil Techniques for Electromagnetic Examination of Tubular Products

an exciting coil and sensing coil or Hall element mounted in a common holder. A Hall element is a semiconductor that by reason of the Hall effect is capable of responding in a manner directly proportional to magnetic-flux density. However, when used with an exciting coil, it should be remembered that eddy current flow is influenced by the excitation frequency.

NOTE 3—Lift-off effect is an important consideration since coupling variations can affect the examination significantly.

7.4 Driving Mechanism—A mechanical device capable of passing the tube through the examination coil or past the probe. It shall operate at a uniform speed with minimum vibration of coil, probe, or tube and maintain the article being examined in proper register or concentricity with the probe or examination coil. Where required, the mechanism shall be capable of uniformly rotating the tube or probe.

7.5 Reference Standard—The standard used to adjust the sensitivity setting of the apparatus shall be sound and of the same nominal alloy, temper, and nominal dimensions as the lot of tubes or pipes to be examined on a production basis. It shall be of sufficient length to permit the required spacing of the artificial discontinuities (at least 4 ft, and preferably longer). Artificial discontinuities made in the tube or pipe shall be centered as nearly as possible on one inside or outside diameter surface of the tube and shall preferably be of one of the following types:

7.5.1 Holes—Holes that are usually drilled completely through the wall may be used. Care should be taken during drilling to avoid distortion of the tube (or pipe) and hole.

7.5.2 Notches—Notches may be produced by electric discharge machining (EDM), milling, or other means. Longitudinal or transverse notches or both may be used (NOTE 4). Orientation, dimensions (width, length, and depth), and configuration of the notches affect the response of the eddy current system. Notch depth is usually specified as a percentage of nominal wall thickness of the tubular product being examined. Notches may be placed on the outer, inner, or both surfaces of the reference (calibration) standard. Outer surface notches provide an indication of system response to discontinuities originating on the outer tube surface, whereas inner surface notches provide an indication of system response to discontinuities originating on the inner tube surface (NOTE 5).

NOTE 4—Longitudinal notch standards are normally used when examining with rotating probe systems.

NOTE 5—The density of eddy currents decreases nearly exponentially with increasing distance from the surface nearest the coil, and the sensitivity to subsurface discontinuities decreases with the change in depth allowing the use of phase analysis techniques.

7.5.3 The configuration, orientation, and dimensions (diameter of holes and the width, length, and depth of notches) of the artificial discontinuities to be used for establishing acceptance limits should be subject to agreement between supplier and purchaser.

8. Adjustment and Standardization of Apparatus Sensitivity

8.1 Select the apparatus, examination frequency, coil or probe, or both, design, phase discrimination, and other circuitry

as well as speed of examining which shall demonstrate the system capability for detecting the discontinuities of interest.

8.2 Fabricate the applicable reference standard in accordance with the agreement between the purchaser and tubing supplier.

8.3 Adjust the apparatus to obtain an optimum signal-to-noise ratio with the minimum sensitivity required to detect the artificial discontinuities in the reference standard. Do this under conditions (such as examining speed) identical to those to be used in production examination of the tubular products.

8.4 Determine the end effect by using a special reference tube or pipe containing a series of notches or holes near one or both of the ends and passing this reference standard through the system at production examination speeds. If notches or holes are placed near only one of the ends, pass the tube through the system backwards and forwards.

9. Procedure

9.1 Standardize the apparatus at the start of the examination run using the reference standard. The recommended maximum interval between re-standardization is four hours although more or less frequent re-standardization may be done by agreement between using parties, or whenever improper functioning of the equipment is suspected. If improper functioning is found, re-standardize the apparatus and re-examine all tubes or pipes examined during the period since the last successful standardization.

9.2 Pass the lot of tubes or pipes to be examined through the examination coil or past the probe coil of the apparatus adjusted to the sensitivity as described in Section 8. Set aside tubes or pipes with discontinuities indicated by the apparatus. It is recommended that tubes with discontinuity indications be re-examined in accordance with the purchase specification.

9.3 Tubes or pipes may be examined in the final drawn, annealed, heat treated, as-welded, or other step in processing. The point in processing at which examination is made should be agreed upon by the supplier and the purchaser. The tubes should be free of any substance that may interfere with the examination.

10. Supplemental Information Regarding Eddy Current Examination of High Alloy Steels and Similar Alloys

10.1 In the eddy current examination of austenitic chromium-nickel stainless steels it has been found that examination frequencies ranging from less than 1 kHz to more than 1 MHz can be used. The more commonly used operating frequencies are in the range, 1 kHz to 125 kHz. The exact frequency used will depend on the application.

Example—If thin-walled tubular products are to be examined or surface rather than subsurface discontinuities are to be detected, higher frequencies are used. For heavy-walled tubes, subsurface discontinuities well below the surface require the use of a lower frequency. Choice of examination frequency will determine the size of discontinuity that can be detected.

10.2 As in any eddy current examination, the depth and orientation of the discontinuity below the entry surface will