



Designation: D8387/D8387M – 21

Standard Test Method for High Bypass – Low Bearing Interaction Response of Polymer Matrix Composite Laminates¹

This standard is issued under the fixed designation D8387/D8387M; the number immediately following the designation indicates the year of original adoption or, in the case of revision, the year of last revision. A number in parentheses indicates the year of last reapproval. A superscript epsilon (ϵ) indicates an editorial change since the last revision or reapproval.

1. Scope

1.1 This test method determines the uniaxial high bypass - low bearing interaction response of multi-directional polymer matrix composite laminates reinforced by high-modulus fibers using a two-fastener hard point joint specimen. The scope of this test method is limited to net section (bypass) failure modes. Standard specimen configurations using fixed values of test parameters are described for this procedure. A number of test parameters may be varied within the scope of the standard, provided that the parameters are fully documented in the test report. The composite material forms are limited to continuous-fiber or discontinuous-fiber (tape or fabric, or both) reinforced composites for which the laminate is balanced and symmetric with respect to the test direction. The range of acceptable test laminates and thicknesses are described in 8.2.1. This test method was previously published under Test Method D7248/D7248M-17 Procedure C.

1.2 This test method is consistent with the recommendations of Composite Materials Handbook, CMH-17, which describes the desirable attributes of a bearing/bypass interaction response test method.

1.3 The two-fastener test configurations described in this test method are intended to provide data in the relatively high bypass, low bearing part of the composite bolted joint bearing-bypass interaction diagram. This data complements the data from filled hole tension and compression (Practice D6742/D6742M), bearing (Test Method D5961/D5961M), and low bypass/high bearing interaction (Test Method D7248/D7248M) tests.

1.4 This test method requires careful specimen design, instrumentation, data measurement, and data analysis. The use of this test method requires close coordination between the test requestor and the test lab personnel. Test requestors need to be familiar with the data analysis procedures of this test method

and should not expect test labs who are unfamiliar with this test method to be able to produce acceptable results without close coordination.

1.5 *Units*—The values stated in either SI units or inch-pound units are to be regarded separately as standard. The values stated in each system are not necessarily exact equivalents; therefore, to ensure conformance with the standard, each system shall be used independently of the other, and values from the two systems shall not be combined.

1.5.1 Within the text, the inch-pound units are shown in brackets.

1.6 *This standard does not purport to address all of the safety concerns, if any, associated with its use. It is the responsibility of the user of this standard to establish appropriate safety, health, and environmental practices and determine the applicability of regulatory limitations prior to use.*

1.7 *This international standard was developed in accordance with internationally recognized principles on standardization established in the Decision on Principles for the Development of International Standards, Guides and Recommendations issued by the World Trade Organization Technical Barriers to Trade (TBT) Committee.*

2. Referenced Documents

2.1 *ASTM Standards*:²

D792 Test Methods for Density and Specific Gravity (Relative Density) of Plastics by Displacement

D883 Terminology Relating to Plastics

D2584 Test Method for Ignition Loss of Cured Reinforced Resins

D2734 Test Methods for Void Content of Reinforced Plastics

D3171 Test Methods for Constituent Content of Composite Materials

D3878 Terminology for Composite Materials

D5229/D5229M Test Method for Moisture Absorption Properties and Equilibrium Conditioning of Polymer Matrix Composite Materials

¹ This test method is under the jurisdiction of ASTM Committee D30 on Composite Materials and is the direct responsibility of Subcommittee D30.05 on Structural Test Methods.

Current edition approved April 1, 2021. Published June 2021. DOI: 10.1520/D8387_D8387M-21.

² For referenced ASTM standards, visit the ASTM website, www.astm.org, or contact ASTM Customer Service at service@astm.org. For *Annual Book of ASTM Standards* volume information, refer to the standard's Document Summary page on the ASTM website.

- D5687/D5687M** Guide for Preparation of Flat Composite Panels with Processing Guidelines for Specimen Preparation
- D5766/D5766M** Test Method for Open-Hole Tensile Strength of Polymer Matrix Composite Laminates
- D5961/D5961M** Test Method for Bearing Response of Polymer Matrix Composite Laminates
- D6484/D6484M** Test Method for Open-Hole Compressive Strength of Polymer Matrix Composite Laminates
- D6742/D6742M** Practice for Filled-Hole Tension and Compression Testing of Polymer Matrix Composite Laminates
- D7248/D7248M** Test Method for Bearing/Bypass Interaction Response of Polymer Matrix Composite Laminates Using 2-Fastener Specimens
- E4** Practices for Force Verification of Testing Machines
- E6** Terminology Relating to Methods of Mechanical Testing
- E83** Practice for Verification and Classification of Extensometer Systems
- E122** Practice for Calculating Sample Size to Estimate, With Specified Precision, the Average for a Characteristic of a Lot or Process
- E177** Practice for Use of the Terms Precision and Bias in ASTM Test Methods
- E251** Test Methods for Performance Characteristics of Metallic Bonded Resistance Strain Gages
- E456** Terminology Relating to Quality and Statistics
- E1237** Guide for Installing Bonded Resistance Strain Gages
- 2.2 *Other Document.*³
- CMH-17** Composite Materials Handbook-17, Polymer Matrix Composites, Vol 1, Section 7

3. Terminology

3.1 *Definitions*—Terminology **D3878** defines terms relating to high-modulus fibers and their composites. Terminology **D883** defines terms relating to plastics. Terminology **E6** defines terms relating to mechanical testing. Terminology **E456** and Practice **E177** define terms relating to statistics. In the event of a conflict between terms, Terminology **D3878** shall have precedence over the other documents.

NOTE 1—If the term represents a physical quantity, its analytical dimensions are stated immediately following the term (or letter symbol) in fundamental dimension form, using the following ASTM standard symbology for fundamental dimensions, shown within square brackets: $[M]$ for mass, $[L]$ for length, $[T]$ for time, $[\theta]$ for thermodynamic temperature, and $[nd]$ for non-dimensional quantities. Use of these symbols is restricted to analytical dimensions when used with square brackets, as the symbols may have other definitions when used without the brackets.

3.2 *Definitions of Terms Specific to This Standard:*

3.2.1 *bearing area*, $[L^2]$, n —the area of that portion of a specimen used to normalize applied loading into an effective bearing stress; equal to the diameter of the fastener multiplied by the thickness of the specimen.

3.2.2 *bearing force*, P $[MLT^{-2}]$, n —the in-plane force transmitted by a fastener to a specimen at the fastener hole.

3.2.3 *bearing strain*, $\epsilon,^{br}$ $[nd]$, n —the normalized hole deformation in a specimen, equal to the deformation of the

bearing hole in the direction of the bearing force, divided by the diameter of the hole.

3.2.4 *bearing strength*, F_x^{br-byp} $[ML^{-1}T^{-2}]$, n —the value of bearing stress occurring at the point of bypass (net section) failure.

3.2.5 *bearing stress*, σ^{br} $[ML^{-1}T^{-2}]$, n —the bearing force divided by the bearing area.

3.2.6 *diameter to thickness ratio*, D/h $[nd]$, n —in a bearing specimen, the ratio of the hole diameter to the specimen thickness.

3.2.6.1 *Discussion*—The diameter to thickness ratio may be either a nominal value determined from nominal dimensions or an actual value determined from measured dimensions.

3.2.7 *edge distance ratio*, e/D $[nd]$, n —in a bearing specimen, the ratio of the distance between the center of the hole and the specimen end to the hole diameter.

3.2.7.1 *Discussion*—The edge distance ratio may be either a nominal value determined from nominal dimensions or an actual value determined from measured dimensions.

3.2.8 *gross bypass stress*, f_x^{gr-byp} $[ML^{-1}T^{-2}]$, n —the gross bypass stress for tensile loadings is calculated from the total force bypassing the fastener hole.

3.2.9 *net bypass stress*, $f_x^{net-byp}$ $[ML^{-1}T^{-2}]$, n —the net bypass stress for tensile loading is calculated from the force bypassing the fastener hole minus the force reacted in bearing at the fastener.

3.2.9.1 *Discussion*—For compressive loadings, the gross and net bypass stresses are equal and are calculated using the force that bypasses the fastener hole (since for the compressive loading case, the bearing stress reaction is on the same side of the fastener as the applied force, the force reacted in bearing does not bypass the fastener hole).

3.2.9.2 *Discussion*—Several alternate definitions for gross and net bypass stress have been used historically in the aerospace industry. Comparison of data from tests conforming to this test method with historical data may need to account for differences in the bypass definitions.

3.2.10 *nominal value*, n —a value, existing in name only, assigned to a measurable quantity for the purpose of convenient designation. Tolerances may be applied to a nominal value to define an acceptable range for the quantity.

3.2.11 *ultimate bearing strength*, $F_x^{br_u}$ $[ML^{-1}T^{-2}]$, n —the value of bearing stress, in the direction specified by the subscript, at the maximum force capability of a bearing specimen.

3.2.12 *ultimate gross bypass strength*, F_x^{gr-byp} $[ML^{-1}T^{-2}]$, n —the value of gross bypass stress, in the direction specified by the subscript, at the maximum force capability of the specimen.

3.2.13 *ultimate net bypass strength*, $F_x^{net-byp}$ $[ML^{-1}T^{-2}]$, n —the value of net bypass stress, in the direction specified by the subscript, at the maximum force capability of the specimen.

3.2.14 *width to diameter ratio*, w/D $[nd]$, n —in a bearing specimen, the ratio of specimen width to hole diameter.

3.2.14.1 *Discussion*—The width to diameter ratio may be

³ Available from SAE International (SAE), 400 Commonwealth Dr., Warrendale, PA 15096, <http://www.sae.org>.

either a nominal value determined from nominal dimensions or an actual value, determined as the ratio of the actual specimen width to the actual hole diameter.

3.3 Symbols:

A = gross cross-sectional area (disregarding hole) mm² [in.²]
 C_F = fastener flexibility (Ref 1)⁴
 C_P = plate (specimen) flexibility
 C_S = doubler plate flexibility
 CV = sample coefficient of variation, %
 d = fastener diameter, mm [in.]
 D = hole diameter, mm [in.]
 e/D = actual edge distance ratio
 E_F = fastener modulus, MPa [psi]
 E_{xP} = test specimen laminate modulus, MPa [psi]
 E_{xS} = doubler plate modulus in axial (x) direction, MPa [psi]
 $F_x^{gr_byp-t}$ = ultimate tensile gross bypass strength, MPa [psi].
 $F_x^{net_byp-t}$ = ultimate tensile net bypass strength, MPa [psi]
 $F_x^{gr_byp-c}$ = ultimate compressive gross bypass strength, MPa [psi]
 $F_x^{net_byp-c}$ = ultimate compressive net bypass strength, MPa [psi]
 F^{br_byp} = bearing stress at ultimate bypass strength, MPa [psi]
 g = distance from hole edge to specimen end, mm [in.]
 h = specimen thickness near hole (nominal or actual, as specified), mm [in.]
 k_D = proportion of total force transferred through doubler plates
 k_E = estimate of proportion of total force transferred through fasteners to doubler plates
 k_S = proportion of total force transferred through specimen
 L = distance between fastener centerlines, mm [in.]
 n = number of strain gages on the doubler plate
 n = number of tested specimens
 P = total force applied to specimen, N [lbf]
 P_{D1}, P_{D2} = force in doubler plates, N [lbf]
 P_i = force at i -th data point, N [lbf]
 P_{max} = maximum force prior to failure, N [lbf]
 P_S = force in specimen between fasteners, N [lbf]
 s_{n-1} = sample standard deviation
 t_P = test specimen laminate thickness, mm [in.]
 t_S = doubler plate thickness, mm [in.]
 ν_F = fastener Poisson's ratio
 w = width of specimen across hole, mm [in.]
 w_P = test specimen width, mm [in.]
 w_S = doubler plate width, mm [in.]
 \bar{X} = sample mean (average)
 x_i = measured or derived property
 δ_{1i} = extensometer-1 displacement at i -th data point, mm [in.]
 δ_{2i} = extensometer-2 displacement at i -th data point, mm [in.]
 ϵ_i^{br} = bearing strain, microstrain
 σ_i^{br} = bearing stress at i -th data point, MPa [psi]

⁴ The boldface numbers in parentheses refer to the list of references at the end of this standard.

4. Summary of Test Method

4.1 *Bearing/Bypass Test Procedures*—Definition of the uniaxial bearing/bypass interaction response requires data for varying amounts of bearing and bypass forces at a fastener hole. Fig. 1 shows a typical composite laminate bearing/bypass interaction diagram (Refs 1-3), along with illustrative data from various test types. Data from Practice D6742/D6742M and Test Method D5961/D5961M define the 100 % bypass and bearing ends of the interaction diagram. Test Method D7248/D7248M Procedures A and B provide data in the low bypass/high bearing region. This test method provides data in the high bypass/low bearing region. More complicated test setups have been used to develop data across the full range of bearing/bypass interaction. This test method is limited to cases where the bearing and bypass loads are aligned in the same direction. It is also limited to uniaxial tensile or compressive bypass loads. Test procedures for cases where the bearing and bypass loads act at different directions, or cases with biaxial or shear bypass loads are outside the scope of this test method.

4.1.1 Ultimate strength for all procedures is calculated based on the specimen gross cross-sectional area, disregarding the presence of the hole. While the hole causes a stress concentration and reduced net section, it is common industry practice to develop notched design allowable strengths based on gross section stress to account for various stress concentrations (fastener holes, free edges, flaws, damage, and so forth) not explicitly modeled in the stress analysis. This is consistent with the ASTM D30 test methods for open and filled hole tension and compression strength (Test Methods D5766/D5766M, D6484/D6484M, and Practice D6742/D6742M).

4.2 High Bypass/Low Bearing Double Shear:

4.2.1 A flat, constant rectangular cross-section test specimen with two centerline holes located in the middle of the specimen, as shown in the test specimen drawing of Fig. 2, is axially loaded. Two doubler plates, Fig. 3, are attached to the specimen as shown in Fig. 4 to act as a “hardpoint” which induces bearing forces in the test specimen and plates. The ends of the test specimen are gripped in the jaws of a test machine and loaded in tension or compression.

4.2.1.1 *Unstabilized Configuration (No Support Fixture)*—The ends of the test specimen are gripped in the jaws of a test machine and loaded in tension.

4.2.1.2 *Stabilized Configuration (Using Support Fixture)*—The test specimen is face-supported in a multi-piece bolted support fixture, as shown in Fig. 5. The test specimen/fixture assembly is clamped in hydraulic wedge grips and the force is sheared into the support fixture and then sheared into the specimen. Tensile or compressive force is applied. The stabilization fixture is required for compressive loading and is optional for tensile loading.

4.2.2 The amount of force that is transferred through the doubler plates is determined from the measurement of strain in the plates and test specimen. The force-strain response of the doubler plates and test specimen must be determined using a determinant test setup prior to the bearing/bypass test. Due to uncertainties in the hole tolerances and fastener flexibilities, calculation of the doubler plate forces is not sufficiently

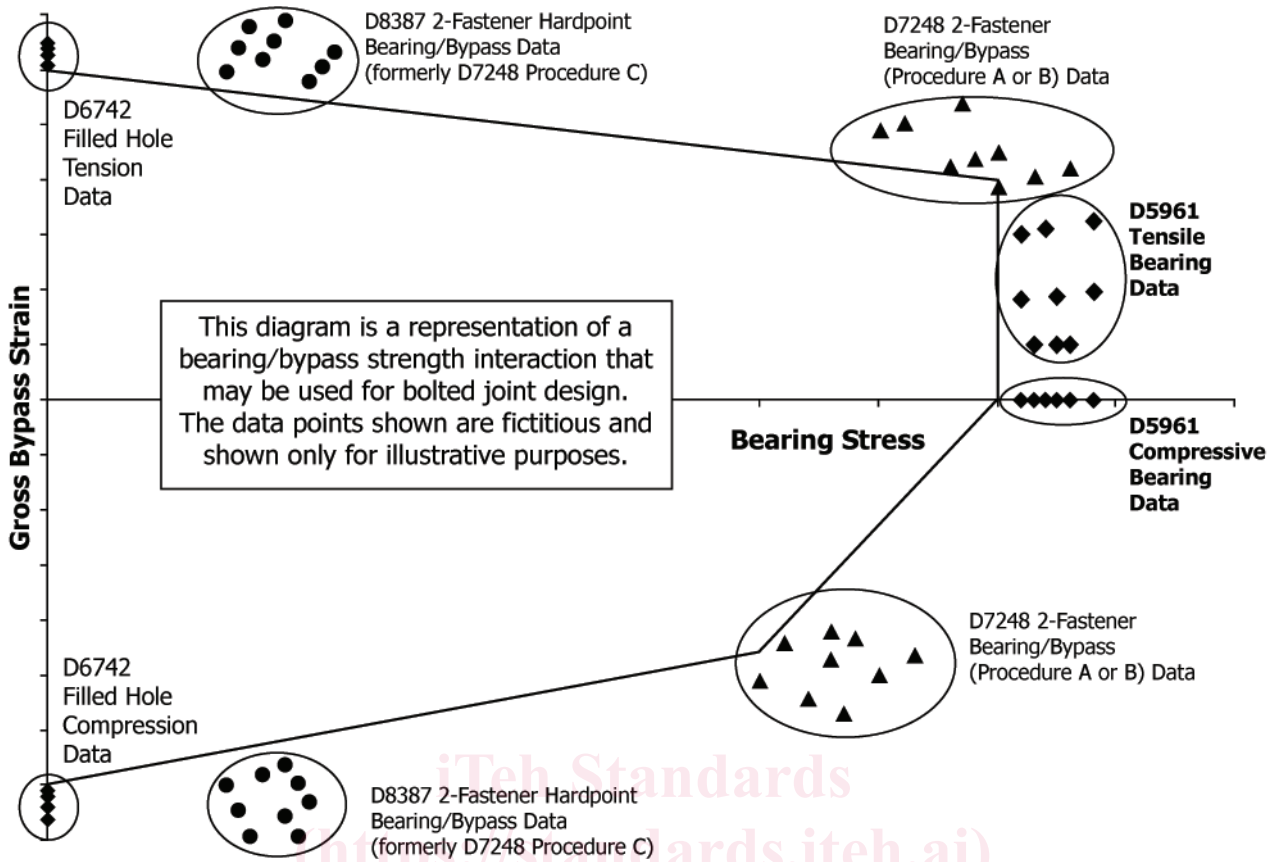

FIG. 1 Illustration of FHT, FHC, Bearing and Bearing/Bypass Bolted Joints Data and Bearing/Bypass Interaction Diagram (Refs 1-3)

reliable for data reduction (equations are provided in this test method for estimating the fastener loads for the purposes of specimen design).

4.2.3 Both the applied force and the associated deformation of the hole(s) are monitored. The applied force is normalized by the projected hole area to yield an effective bearing stress. The specimen is loaded until a two part failure is achieved.

4.2.4 The standard test configuration for this procedure has defined values for the major test parameters. However, the following variations in configuration are allowed and can be considered as being in accordance with this test method as long as the values of all variant test parameters are prominently documented with the results. The standard specimen width has a $w/d = 6$, as bearing failures for this specimen configuration are not common, unlike that for the 2-fastener Test Method D7248/D7248M bypass specimen. This avoids having to put spacers into the support fixture for narrow specimens.

Parameter	Standard	Variation
Loading condition	double-shear	none
Loading type	tensile	compressive
Doubler plate material	steel	yes, if documented
Number of holes	2	none
Countersunk holes	no	none
Hole fit	tight	any, if documented
Fastener torque	9.0-10.7 N·m [80-95 lbf-in.] for tensile load 2.2-3.4 N·m [20-30 lbf-in.] for compressive load	any, if documented
Laminate	quasi-isotropic	any, if documented
Fastener diameter	6 mm [0.250 in.]	any, if documented
w/D ratio	6	any, if documented
D/h ratio	1.2-2	any, if documented

5. Significance and Use

5.1 This test method is designed to produce low bearing / high bypass interaction response data for research and development, and for structural design and analysis. The

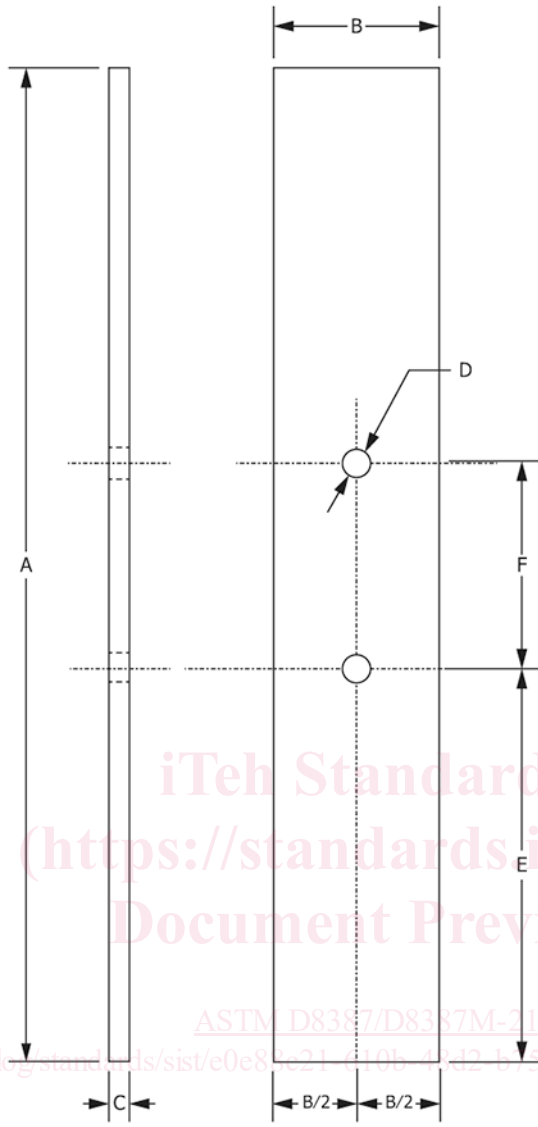

	A	B	C	D	E	F
mm	344	36	2 - 5	6.00	147	50
inch	13.50	1.50	0.08 - 0.20	0.250	5.75	2.00

Tolerances:
 mm: $X \pm 1$; $D + 0.08 / -0.00$
 inch: $X.XX \pm 0.03$; $D + 0.003 / -0.000$

FIG. 2 Double-Shear, 2-Fastener Hardpoint Test Specimen Drawing

standard configuration for this procedure is very specific and is intended as a baseline configuration for developing structural

design data. The high bypass/low bearing double-shear hardpoint configuration is recommended for determining the effect

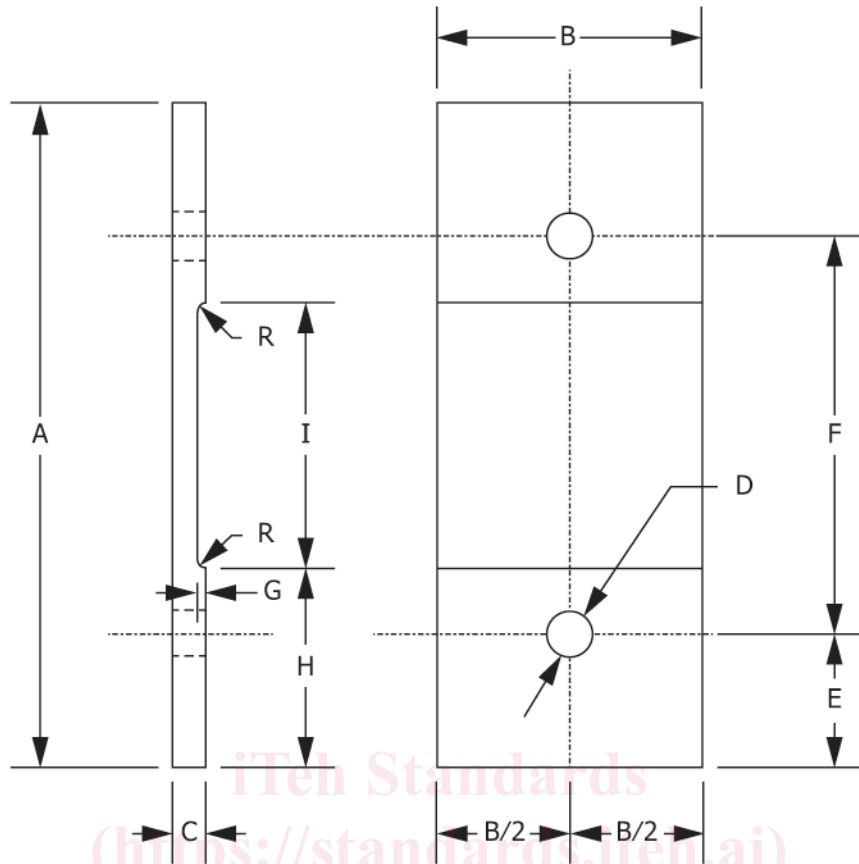

Recommended Material: 17-4 PH Stainless Steel, 1.0 GPa [145 ksi] yield stress									
	A	B	C	D	E	F	G, R	H	I
mm	90	36.0	5.0	6.00	20.0	50.0	1.50	30.0	30.0
inch	3.5	1.50	0.20	0.250	0.75	2.00	0.060	1.17	1.17

(a) Tensile Loading

Recommended Material: 17-4 PH Stainless Steel, 1.0 GPa [145 ksi] yield stress									
	A	B	C	D	E	F	G, R	H	I
mm	90	21.0	5.0	6.00	20.0	50.0	1.50	30.0	30.0
inch	3.5	0.83	0.20	0.250	0.75	2.00	0.060	1.17	1.17

(b) Compressive Loading

Tolerances:

mm: X ± 2; X.X ± 0.8; X.XX ± 0.25; D + 0.08/ -0.00

inch: X.X ± 0.1; X.XX ± 0.03; X.XXX ± 0.010; D + 0.003 /-0.000

FIG. 3 Doubler Plate Drawing

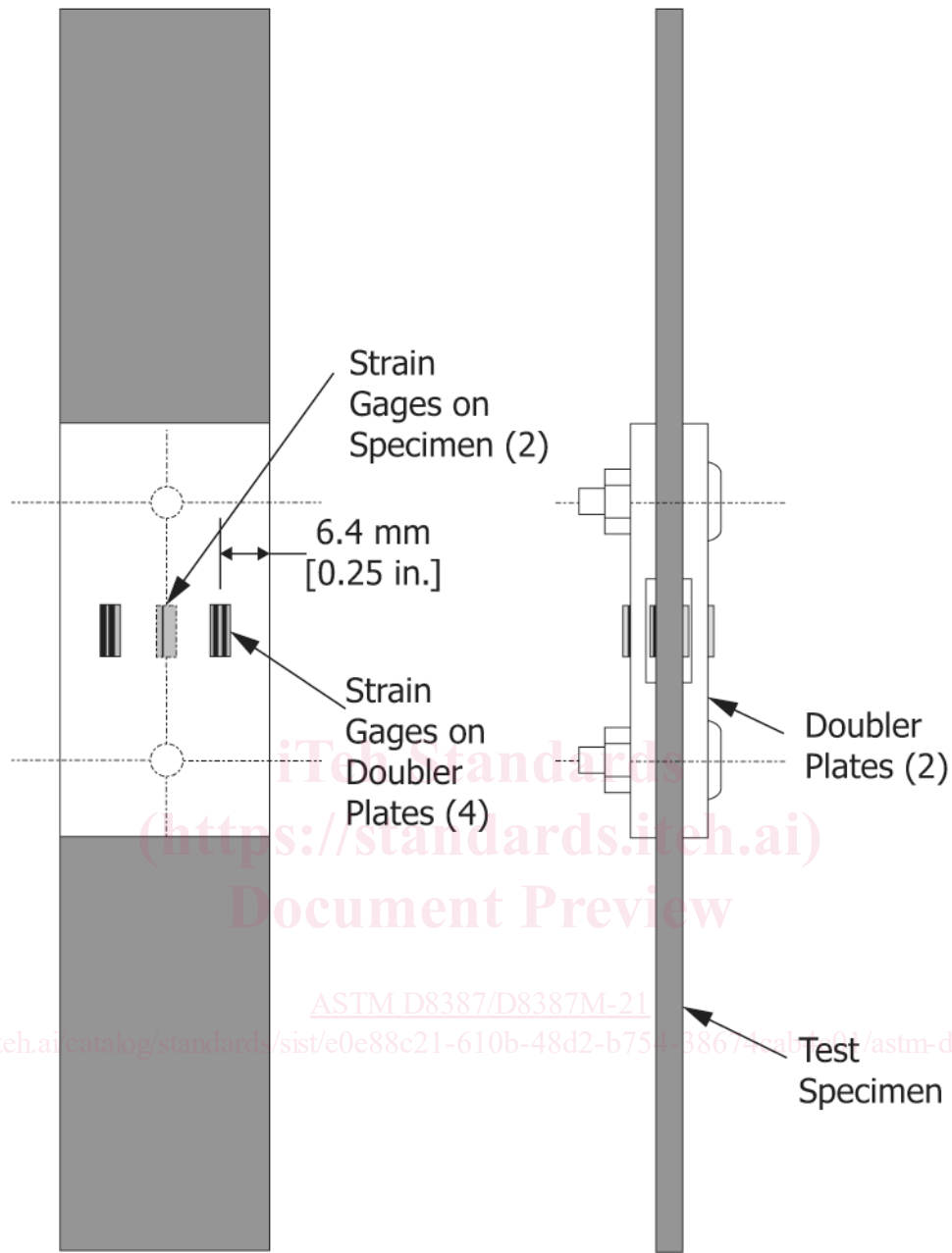

Tolerances:
 mm: X.X ± 0.8
 inch: X.XX ± 0.03

FIG. 4 (a) Tensile Loading—Test Specimen and Doubler Plate Assembly

of low bearing stress levels on bypass strength. While a similar single-shear configuration could be tested, there is insufficient experience with a single-shear configuration to recommend its use at this time.

5.2 General factors that influence the mechanical response of composite laminates and should therefore be reported include the following: material, methods of material preparation and lay-up, specimen stacking sequence, specimen preparation, specimen conditioning, environment of testing,

specimen alignment and gripping, speed of testing, time held at test temperature, void content, and volume percent reinforcement.

5.3 Specific factors that influence the bearing/bypass interaction response of composite laminates and should therefore be reported include not only loading type (tension or compression) but the following: edge distance ratio, width to diameter ratio, diameter to thickness ratio, fastener torque, fastener or

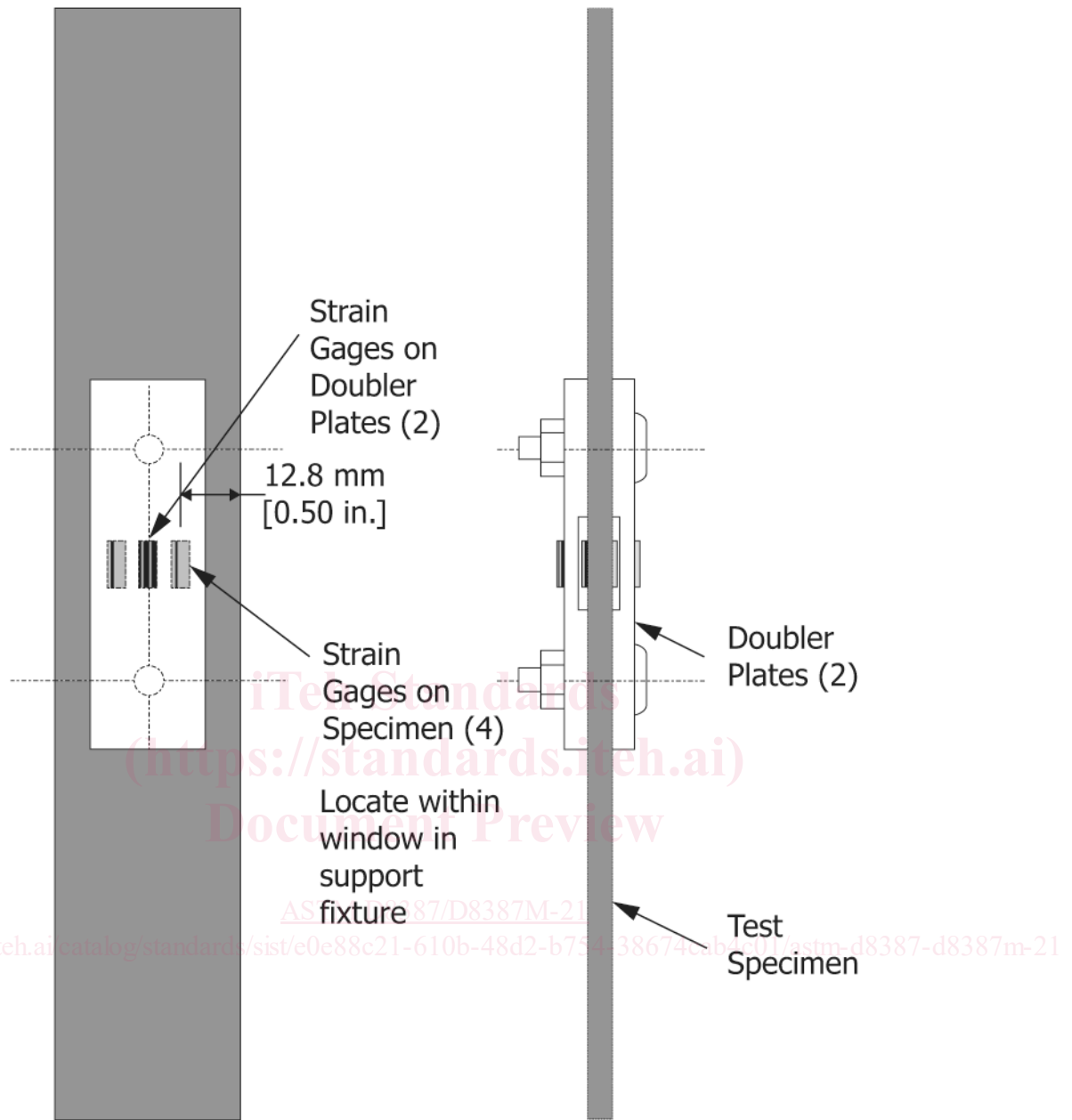

Tolerances:
 mm: X.X ± 0.8
 inch: X.XX ± 0.03

FIG. 4 (b) Compressive Loading—Test Specimen and Doubler Plate Assembly (continued)

pin material, fastener or pin clearance. Properties, in the test direction, which may be obtained from this test method include the following:

- 5.3.1 Filled hole tensile bearing/bypass strength.
- 5.3.2 Filled hole compressive bearing/bypass strength.
- 5.3.3 Bearing stress/bypass strain curve.

6. Interferences

6.1 Refer to Test Method [D7248/D7248M](#) for discussion of interferences with bolted joint bearing/bypass testing.

7. Apparatus

7.1 *Micrometers*—A micrometer with a 4 to 8 mm [0.16 to 0.32 in.] nominal diameter ball interface shall be used to measure the specimen thickness when at least one surface is irregular (such as the bag-side of a laminate). A micrometer with a 4 to 8 mm [0.16 to 0.32 in.] nominal diameter ball interface or with a flat anvil interface shall be used to measure the specimen thickness when both surfaces are smooth (such as tooled surfaces). A micrometer or caliper, with a flat anvil

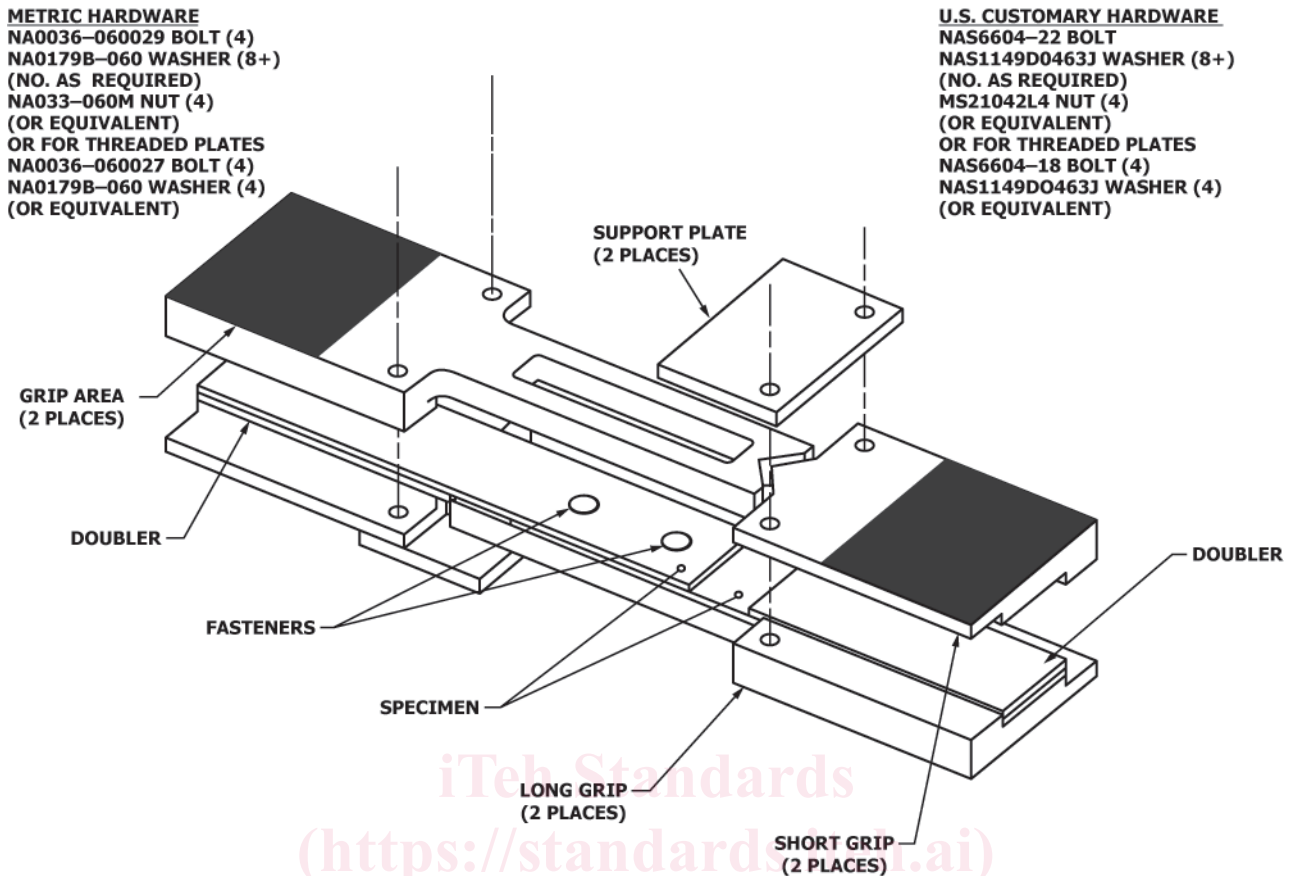

FIG. 5 Support Fixture Assembly (for Details of the Support Fixture, See Test Method D5961/D5961M)

interface, shall be used to measure the width of the specimen. The accuracy of the instruments shall be suitable for reading to within 1% of the sample dimensions. For typical specimen geometries, an instrument with an accuracy of ± 0.0025 mm [± 0.0001 in.] is adequate for the thickness measurement, while an instrument with an accuracy of ± 0.025 mm [± 0.001 in.] is adequate for the width measurement. Additionally, a micrometer or gage capable of determining the hole diameters to ± 0.025 mm [± 0.001 in.] shall be used.

NOTE 2—The accuracies given above are based on achieving measurements that are within 1 % of the sample width and thickness.

7.2 *Loading Fasteners or Pins*—The fastener (or pin) type shall be specified as an initial test parameter and reported. The assembly torque (if applicable) shall be specified as an initial test parameter and reported. This value may be a measured torque or a specification torque for fasteners with lock-setting features. If washers are utilized, the washer type, number of washers, and washer location(s) shall be specified as initial test parameters and reported. The reuse of fasteners is not recommended due to potential differences in through-thickness clamp-up for a given torque level, caused by wear of the threads or deformation of the locking features.

7.3 *Torque Wrench*—If using a torqued fastener, a torque wrench used to tighten the fastener shall be capable of determining the applied torque to within ± 10 % of the desired value.

7.4 *Fixture*—Doubler plates, Fig. 3, are attached to the test specimen using two fasteners. In some cases, it may be desirable to use doubler plates that are more closely matched in stiffness to the test laminate, particularly when testing soft laminate materials or layups. These plates may typically be reused, as the force transferred into the plates should be relatively small. The holes in the plates should be examined for bearing deformation after each use and replaced if deformation is observed. If the doubler plates are replaced, the new plates shall be calibrated in accordance with 11.3.

7.4.1 For compressive tests, the doubler plates must be sized to fit into the support fixture window. See alternate described in 7.4.5.

7.4.2 For test laminates that are narrower than the standard specimen width, which may be required in some cases to obtain a bypass failure mode, the standard doubler plate widths may be used. Actual widths shall be used in the force proportion estimate calculations in 8.2.2.

7.4.3 *Strain Gages*—For tensile tests, two axial strain gages shall be mounted on each doubler plate at the locations shown in Fig. 4a. For compressive tests, one axial strain gage shall be mounted on each doubler plate at the location shown in Fig. 4b.

7.4.4 *Machining Precision*—Doubler plates and calibration loading plates require high machining quality, hole diameter tolerances, hole positioning, hole perpendicularity, flatness, etc.

7.4.5 For compressive tests, an alternate to doublers that fit within the support fixture window is to use full width doublers (same as for tensile tests). In this case, shims (4 total) equal to the doubler plate thickness will be required at each end of the specimen to provide a flat surface to interface with the support fixture. In some cases, test laminate failure may then occur at the gap between the doubler and shim; a mitigation for this situation is to modify the doublers and shims to have a chevron shape similar to the support fixture such that there is no unsupported laminate area across the specimen width.

7.5 *Support Fixture (Compressive Loading)*—If compressive loads are applied or if requested in the test plan, a support fixture shall be used to stabilize the specimen. The fixture is a face-supported test fixture as shown in Fig. 5. The fixture consists of two short-grip/long-grip assemblies, two support plates, and stainless steel shims as required to maintain a nominally zero (0.00 to 0.12-mm [0.000 to 0.005-in.] tolerance) gap between the support plates and the long grips. If this gap does not meet the minimum requirement, shim the contact area between the support plate and the short grip with stainless steel shim stock. If the gap is too large, shim between the support plate and the long grip, holding the shim stock on the support plate with tape. The fixture should be checked for conformity to engineering drawings. Each short-grip/long-grip assembly is line-drilled and must be used as a matched set. The threading of the support plate is optional. The fixture is hydraulically gripped on each end and the force is sheared by means of friction through the fixture and into the test specimen. A cutout exists on both faces of the fixture for a thermocouple, fastener(s), and surface-mounted extensometer. The long and short fixtures have an undercut along the corner of the specimen grip area so that specimens are not required to be chamfered and to avoid damage caused by the radius. The fixtures also allow a slight clearance between the fixture and the gage section of the specimen, in order to minimize grip failures and friction effects. This fixture does not allow specimens to be end loaded.

7.5.1 *Support Fixture Details*—The detailed drawings for manufacturing the support fixture are contained in Test Method D5961/D5961M. Other fixtures that meet the requirements of this section may be used.

NOTE 3—Experience has shown that fixtures may be damaged in use; thus, periodic re-inspection of the fixture dimensions and tolerances is important.

7.6 *Testing Machine*—The testing machine shall be in conformance with Practices E4, and shall satisfy the following requirements:

7.6.1 *Testing Machine Configuration*—The testing machine shall have both an essentially stationary head and a movable head. A short loading train and rigidly mounted hydraulic grips shall be used for Procedure B when using the support fixture.

7.6.2 *Drive Mechanism*—The testing machine drive mechanism shall be capable of imparting to the movable head a controlled velocity with respect to the stationary head. The velocity of the movable head shall be capable of being regulated as specified in 11.4.

7.6.3 *Force Indicator*—The testing machine force-sensing device shall be capable of indicating the total force being

carried by the test specimen. This device shall be essentially free from inertia-lag at the specified rate of testing and shall indicate the force with an accuracy over the force range(s) of interest of within $\pm 1\%$ of the indicated value.

7.6.4 *Grips*—Each head of the testing machine shall be capable of holding one end of the test assembly so that the direction of force applied to the specimen is coincident with the longitudinal axis of the specimen. Wedge grips shall apply sufficient lateral pressure to prevent slippage between the grip face and the test specimen or support fixture.

7.7 *Bearing Deformation Indicator*—Bearing deformation data shall be determined by an indicator device able to measure longitudinal hole deformation, as shown in Fig. 6. The arms of the indicator device must fit within the stabilization fixture when a specimen with a width less than 36 mm [1.5 in.] is tested in the standard fixture. Transducer gage lengths on the order of 50 mm [2.0 in.] are typically used. The transducers of the bearing deformation indicator may provide either individual signals to be externally averaged or an electronically averaged signal. The indicator may consist of two matched strain-gage extensometers or displacement transducers such as LVDTs or DCDTs. Attachment of the bearing deformation indicator to the specimen shall not cause damage to the specimen surface. Transducers shall satisfy, at a minimum, Practice E83, Class B-2 requirements for the displacement range of interest, and shall be calibrated over that range in accordance with Practice E83. The transducers shall be essentially free of inertia-lag at the specified speed of testing.

7.8 *Conditioning Chamber*—When conditioning materials at non-laboratory environments, a temperature-/vapor-level controlled environmental conditioning chamber is required that shall be capable of maintaining the required temperature to within $\pm 3\text{ }^{\circ}\text{C}$ [$\pm 5\text{ }^{\circ}\text{F}$] and the required relative humidity level to within $\pm 3\%$. Chamber conditions shall be monitored either on an automated continuous basis or on a manual basis at regular intervals.

7.9 *Environmental Test Chamber*—An environmental test chamber is required for test environments other than ambient testing laboratory conditions. This chamber shall be capable of maintaining the gage section of the test specimen at the required test environment during the mechanical test within $\pm 3\text{ }^{\circ}\text{C}$ or $\pm 5\text{ }^{\circ}\text{F}$.

7.10 *Strain-Indicating Device*—Strain data, when required, shall be determined by means of bonded resistance strain gages.

7.10.1 *Bonded Resistance Strain Gage Selection*—Strain gage selection is based on the type of material to be tested. A minimum active gage length of 3 mm [0.125 in.] is recommended for composite laminates fabricated from unidirectional layers. Larger strain gage sizes may be more suitable for some textile fabrics. Gage calibration certification shall comply with Test Method E251. Strain gages with a minimum normal strain range of approximately 3% are recommended. When testing textile fabric laminates, gage selection should consider the use of an active gage length that is at least as great as the characteristic repeating unit of the fabric. Some guidelines on the use of strain gages on composite materials follow.