



INTERNATIONAL STANDARD

AMENDMENT 2

**Utility connections in port –
Part 1: High voltage shore connection (HVSC) systems – General requirements**

[IEC/IEEE 80005-1:2019/AMD2:2023](https://standards.iteh.ai/catalog/standards/sist/009b98e1-0e03-449d-9455-b156cd9bd3fc/iec-ieee-80005-1-2019-amd2-2023)

<https://standards.iteh.ai/catalog/standards/sist/009b98e1-0e03-449d-9455-b156cd9bd3fc/iec-ieee-80005-1-2019-amd2-2023>





THIS PUBLICATION IS COPYRIGHT PROTECTED

Copyright © 2023 IEC/ISO/IEEE

All rights reserved. Unless otherwise specified, no part of this publication may be reproduced or utilized in any form or by any means, electronic or mechanical, including photocopying and microfilm, without permission in writing from IEC, ISO or IEEE at the respective address given below.

IEC Secretariat
3, rue de Varembé
CH-1211 Geneva 20
Switzerland
Tel.: +41 22 919 02 11
info@iec.ch
www.iec.ch

ISO copyright office
Case postale 56
CH-1211 Geneva 20
Switzerland
Tel.: +41 22 749 01 11
copyright@iso.org
www.iso.org

Institute of Electrical and Electronics Engineers, Inc.
3 Park Avenue
New York, NY 10016-5997
United States of America
stds.info@ieee.org
www.ieee.org

About the IEC

The International Electrotechnical Commission (IEC) is the leading global organization that prepares and publishes International Standards for all electrical, electronic and related technologies.

About IEC publications

The technical content of IEC publications is kept under constant review by the IEC. Please make sure that you have the latest edition, a corrigendum or an amendment might have been published.

IEC publications search - webstore.iec.ch/advsearchform

The advanced search enables to find IEC publications by a variety of criteria (reference number, text, technical committee, ...). It also gives information on projects, replaced and withdrawn publications.

IEC Just Published - webstore.iec.ch/justpublished

Stay up to date on all new IEC publications. Just Published details all new publications released. Available online and once a month by email.

IEC Customer Service Centre - webstore.iec.ch/csc

If you wish to give us your feedback on this publication or need further assistance, please contact the Customer Service Centre: sales@iec.ch.

IEC Products & Services Portal - products.iec.ch

Discover our powerful search engine and read freely all the publications previews. With a subscription you will always have access to up to date content tailored to your needs.

Electropedia - www.electropedia.org

The world's leading online dictionary on electrotechnology, containing more than 22 300 terminological entries in English and French, with equivalent terms in 19 additional languages. Also known as the International Electrotechnical Vocabulary (IEV) online.

[IEC/IEEE 80005-1:2019/AMD2:2023](https://standards.iteh.ai/catalog/standards/sist/009b98e1-0e03-449d-9455-b156cd9bd3fc/iec-ieee-80005-1-2019-amd2-2023)

<https://standards.iteh.ai/catalog/standards/sist/009b98e1-0e03-449d-9455-b156cd9bd3fc/iec-ieee-80005-1-2019-amd2-2023>



IEC/IEEE 80005-1

Edition 2.0 2023-08



INTERNATIONAL STANDARD

AMENDMENT 2

**Utility connections in port –
Part 1: High voltage shore connection (HVSC) systems – General requirements**

[IEC/IEEE 80005-1:2019/AMD2:2023](https://standards.iteh.ai/catalog/standards/sist/009b98e1-0e03-449d-9455-b156cd9bd3fc/iec-ieee-80005-1-2019-amd2-2023)

<https://standards.iteh.ai/catalog/standards/sist/009b98e1-0e03-449d-9455-b156cd9bd3fc/iec-ieee-80005-1-2019-amd2-2023>

INTERNATIONAL
ELECTROTECHNICAL
COMMISSION

ICS 47.020.60

ISBN 978-2-8322-7299-2

Warning! Make sure that you obtained this publication from an authorized distributor.

UTILITY CONNECTIONS IN PORT –

Part 1: High voltage shore connection (HVSC) systems – General requirements

FOREWORD

- 1) The International Electrotechnical Commission (IEC) is a worldwide organization for standardization comprising all national electrotechnical committees (IEC National Committees). The object of IEC is to promote international co-operation on all questions concerning standardization in the electrical and electronic fields. To this end and in addition to other activities, IEC publishes International Standards, Technical Specifications, Technical Reports, Publicly Available Specifications (PAS) and Guides (hereafter referred to as “IEC Publication(s)”). Their preparation is entrusted to technical committees; any IEC National Committee interested in the subject dealt with may participate in this preparatory work. International, governmental and nongovernmental organizations liaising with the IEC also participate in this preparation.

ISO (the International Organization for Standardization) is a worldwide federation of national standards bodies (ISO member bodies). The work of preparing International Standards is normally carried out through ISO technical committees. Each member body interested in a subject for which a technical committee has been established has the right to be represented on that committee. International organizations, governmental and non-governmental, in liaison with ISO, also take part in the work. ISO collaborates closely with the International Electrotechnical Commission (IEC) on all matters of electrotechnical standardization.

IEEE Standards documents are developed within IEEE Societies and Standards Coordinating Committees of the IEEE Standards Association (IEEE-SA) Standards Board. IEEE develops its standards through a consensus development process, approved by the American National Standards Institute, which brings together volunteers representing varied viewpoints and interests to achieve the final product. Volunteers are not necessarily members of IEEE and serve without compensation. While IEEE administers the process and establishes rules to promote fairness in the consensus development process, IEEE does not independently evaluate, test, or verify the accuracy of any of the information contained in its standards. Use of IEEE Standards documents is wholly voluntary. IEEE documents are made available for use subject to important notices and legal disclaimers (see <http://standards.ieee.org/IPR/disclaimers.html> for more information).

IEC collaborates closely with ISO and IEEE in accordance with conditions determined by agreement between the organizations. This Triple Logo International Standard was jointly developed by the IEC, ISO and IEEE under the terms of that agreement.

- 2) The formal decisions of IEC on technical matters express, as nearly as possible, an international consensus of opinion on the relevant subjects since each technical committee has representation from all interested IEC National Committees. In the ISO, Draft International Standards adopted by the technical committees are circulated to the member bodies for voting. Publication as an International Standard requires approval by at least 75 % of the member bodies casting a vote. The formal decisions of IEEE on technical matters, once consensus within IEEE Societies and Standards Coordinating Committees has been reached, is determined by a balanced ballot of materially interested parties who indicate interest in reviewing the proposed standard. Final approval of the IEEE Standard document is given by the IEEE Standards Association (IEEE SA) Standards Board.
- 3) IEC/ISO/IEEE Publications have the form of recommendations for international use and are accepted by IEC National Committees/ISO member bodies /IEEE Societies in that sense. While all reasonable efforts are made to ensure that the technical content of IEC/ISO/IEEE Publications is accurate, IEC, ISO or IEEE cannot be held responsible for the way in which they are used or for any misinterpretation by any end user.
- 4) In order to promote international uniformity, IEC National Committees undertake to apply IEC Publications (including IEC/ISO/IEEE Publications) transparently to the maximum extent possible in their national and regional publications. Any divergence between any IEC/ISO/IEEE Publication and the corresponding national or regional publication shall be clearly indicated in the latter.
- 5) IEC, ISO, and IEEE do not provide any attestation of conformity. Independent certification bodies provide conformity assessment services and, in some areas, access to IEC marks of conformity. IEC, ISO and IEEE are not responsible for any services carried out by independent certification bodies.
- 6) All users should ensure that they have the latest edition of this publication.
- 7) No liability shall attach to IEC, ISO or IEEE or their directors, employees, servants or agents including individual experts and members of technical committees and IEC National Committees and ISO member bodies, or volunteers of IEEE Societies and the Standards Coordinating Committees of the IEEE Standards Association (IEEE SA) Standards Board, for any personal injury, property damage or other damage of any nature whatsoever, whether direct or indirect, or for costs (including legal fees) and expenses arising out of the publication, use of, or reliance upon, this IEC/ISO/IEEE Publication or any other IEC, ISO or IEEE Publications.
- 8) Attention is drawn to the normative references cited in this publication. Use of the referenced publications is indispensable for the correct application of this publication.

- 9) Attention is drawn to the possibility that implementation of this IEC/ISO/IEEE Publication may require use of material covered by patent rights. By publication of this standard, no position is taken with respect to the existence or validity of any patent rights in connection therewith. IEC, ISO or IEEE shall not be held responsible for identifying Essential Patent Claims for which a license may be required, for conducting inquiries into the legal validity or scope of Patent Claims or determining whether any licensing terms or conditions provided in connection with submission of a Letter of Assurance, if any, or in any licensing agreements are reasonable or non-discriminatory. Users of this standard are expressly advised that determination of the validity of any patent rights, and the risk of infringement of such rights, is entirely their own responsibility. Further information may be obtained from ISO or the IEEE Standards Association.

This amendment has been prepared by IEC technical committee 18: Electrical installations of ships and of mobile and fixed offshore units, in cooperation with

- IEC subcommittee 23H: Plugs, socket-outlets and couplers for industrial and similar applications, and for electric vehicles, of IEC technical committee 23: Electrical accessories,
- ISO subcommittee 3: Piping and machinery, of ISO technical committee 8: Ships and marine technology, and
- IEEE IAS Petroleum and chemical industry committee.

This document is published as a triple logo (IEC, ISO and IEEE) standard.

The text of this amendment is based on the following documents:

Draft	Report on voting
18/1810/FDIS	18/1850/RVD

Full information on the voting for the approval of this amendment can be found in the report on voting indicated in the above table. In ISO, the amendment has been approved by XXX P members out of YYY having cast a vote.

The language used for the development of this Amendment is English.

This document was drafted in accordance with ISO/IEC Directives, Part 2, and developed in accordance with ISO/IEC Directives, Part 1 and ISO/IEC Directives, IEC Supplement, available at www.iec.ch/members_experts/refdocs. The main document types developed by IEC are described in greater detail at www.iec.ch/standardsdev/publications.

The committee has decided that the contents of this amendment and the base publication will remain unchanged until the stability date indicated on the IEC website under "http://webstore.iec.ch" in the data related to the specific publication. At this date, the publication will be

- reconfirmed,
 - withdrawn,
 - replaced by a revised edition, or
 - amended.
-

4 General requirements

Add, after the existing 4.9, the following new subclause:

4.10 Ship specific annexes

Annex B to Annex G are ship specific annexes that include additional requirements to safety and compatibility for compliant ships at different compliant berths.

iTeh STANDARD PREVIEW
(standards.iteh.ai)

[IEC/IEEE 80005-1:2019/AMD2:2023](https://standards.iteh.ai/catalog/standards/sist/009b98e1-0e03-449d-9455-b156cd9bd3fc/iec-ieee-80005-1-2019-amd2-2023)

<https://standards.iteh.ai/catalog/standards/sist/009b98e1-0e03-449d-9455-b156cd9bd3fc/iec-ieee-80005-1-2019-amd2-2023>

Additional annex:

Annex G (normative)

Additional requirements for vehicle carriers

G.1 General

Annex G describes the additional requirements to HVSC systems of vehicle carriers, meaning multi-deck roll-on, roll-off cargo ships designed to carry empty cars and trucks, other than those vessel types in Annex B.

The clause numbering of Annex G follows that of the main body of the text. Hence, the numbering is not necessarily continuous. Any content which is not explicitly mentioned applies, without modification. For example, G.4.1 refers to 4.1 in the main body.

G.4.1 System description

The general system diagram is shown in Figure G.1.

iTeh STANDARD PREVIEW
(standards.iteh.ai)

[IEC/IEEE 80005-1:2019/AMD2:2023](https://standards.iteh.ai/catalog/standards/sist/009b98e1-0e03-449d-9455-b156cd9bd3fc/iec-ieee-80005-1-2019-amd2-2023)

<https://standards.iteh.ai/catalog/standards/sist/009b98e1-0e03-449d-9455-b156cd9bd3fc/iec-ieee-80005-1-2019-amd2-2023>

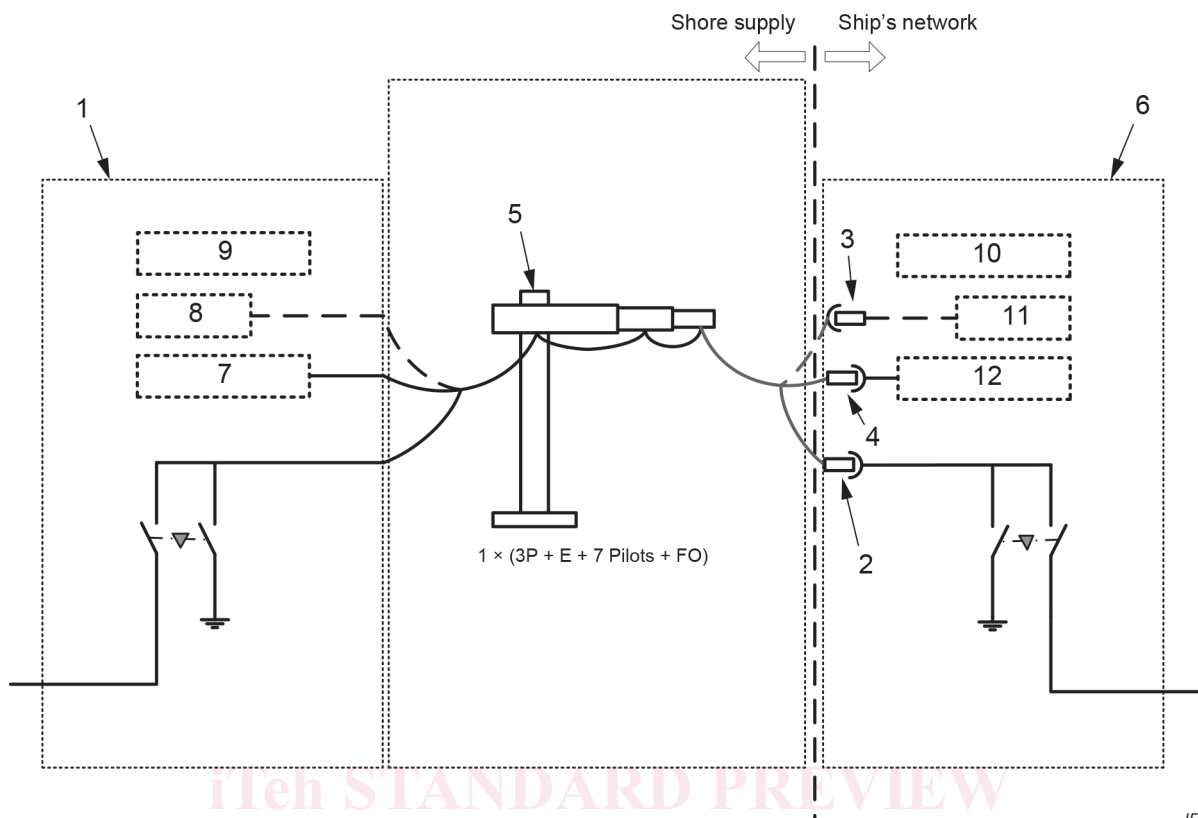

ITEH STANDARD PREVIEW
(standards.iteh.ai)

IEC

Key

- 1 shore supply system
- 2 Power ship connector (shore-side) and ship inlet (on-board)
- 3 fibre optic communication for control and monitoring (integrated in power cable); socket-outlet (shore-side) and plug (on-board) (this document does not specify requirements for optic communication)
- 4 pilot wires (integrated in plug and socket-outlet)
- 5 cable management system, here shown as shore-side crane
- 6 on-board shore connection switchboard
- 7 interlocks with pilot wire shore side
- 8 control shore side
- 9 protection relaying shore side
- 10 protection relaying ship side
- 11 control ship side
- 12 interlocks with pilot wire ship side

Figure G.1 – General system diagram

G.4.6.4 Electrical equipment in areas where flammable gas or vapour and/or combustible dust can be present

HVSC systems shall not be installed in areas which may become hazardous areas, such as car decks, upon failure of required air changes per hour during loading and offloading cargo or during normal operation.

G.5.1 Voltages and frequencies

The nominal voltage shall be 11 kV 60 Hz.

G.6.1 General

It is possible galvanic isolation is not required where a HV shore supply is dedicated to supply only ships which have galvanic isolation on board. A risk assessment shall be performed.

G.6.2.3 Neutral earthing resistor

Where a shore side transformer is used, the star point shall be earthed, through a neutral earthing resistor of 335 Ω .

G.7.1 General

Only one connector shall be used for HVSC. The maximum system demand shall be 6,5 MVA.

G.7.2.1 General

The cable management system shall be fitted at the shore side facility for vehicle carriers including pure car carriers (see Figure G.1).

Vehicle carriers that always have starboard side facing the quayside shall have the HVSC connection on the starboard side less than 100 m from the aft of the ship, alongside the quay. Figure G.2 shows the safety circuits.

The control power voltage shall be less than 60 V DC or 25 V AC safety extra-low voltage type source as per IEC 60364-4-41.

STANDARD PREVIEW
(standards.iteh.ai)

[IEC/IEEE 80005-1:2019/AMD2:2023](https://standards.iteh.ai/catalog/standards/sist/009b98e1-0e03-449d-9455-b156cd9bd3fc/iec-ieee-80005-1-2019-amd2-2023)

<https://standards.iteh.ai/catalog/standards/sist/009b98e1-0e03-449d-9455-b156cd9bd3fc/iec-ieee-80005-1-2019-amd2-2023>

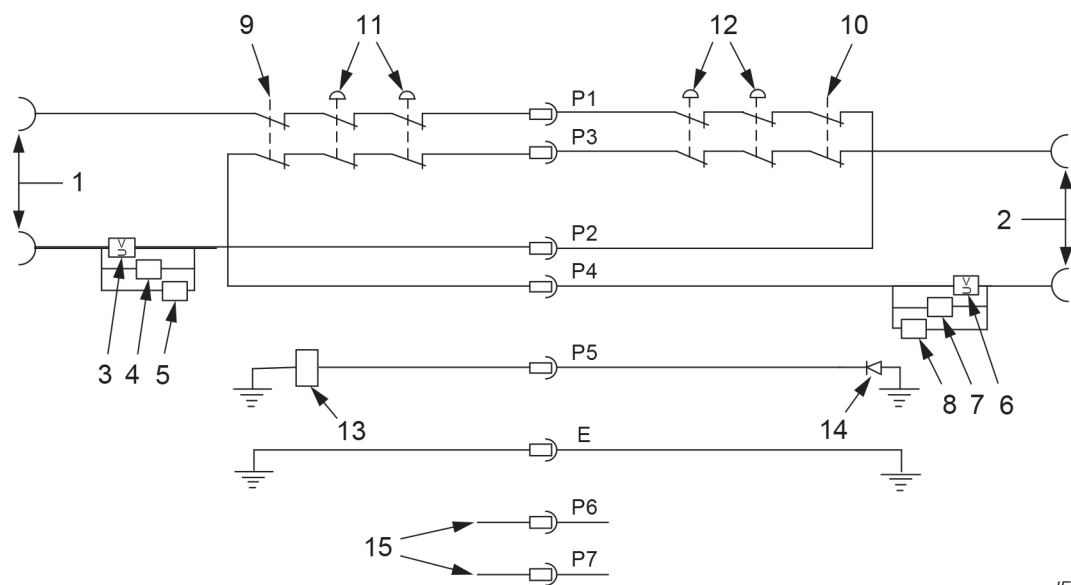

IEC

Key

1	control power pilot loop shore-side	9	control ES shore-side (emergency shutdown)
2	control power pilot loop on-board	10	control ES on-board (emergency shutdown)
3	circuit breaker undervoltage coil (shore-side)	11	manual ES shore-side (two shown)
4	safety circuit coil on shore-side	12	manual ES on-board (two shown)
5	earthing switch permission shore-side	13	equipotential bond monitoring device (where utilized)
6	circuit breaker undervoltage coil (on-board)	14	equipotential bond monitoring termination device (where utilized)
7	safety circuit coil on-board	15	spare pins/pilots
8	earthing switch permission on-board	E	earth (ground) connection (PE)
P1 to P7	See key in Figure G.3.		

NOTE Circuit breaker undervoltage coil (shore-side and on-board) can be directly connected to the safety circuit or through a safety relay (or equivalent).

Figure G.2 – Safety circuits

G.7.2.5 Equipotential bond monitoring

Equipotential bond termination device, where utilized, shall meet the following requirements:

- a) characteristic: Zener diode;
- b) Zener voltage: 5,6 V ± 0,03 V DC at 100 mA;
- c) forward voltage: 0,5 V ± 0,1 V DC at 100 mA;
- d) maximum impedance: 20 mΩ at 100 mA;
- e) operating temperature: -40 °C to 60 °C;
- f) current range: 2 mA to 25 A;
- g) frequency range: 0 kHz to 20 kHz, -3 db.

NOTE Other methods of monitoring the equipotential bond are acceptable (see 4.2.2).

G.7.3.1 General

General arrangement of ship connector and ship inlet shall be in accordance with IEC 62613-2:2016, Annex J, and Figure G.3 below.