



Designation: ~~C212–20~~ C212 – 21

## Standard Specification for Structural Clay Facing Tile<sup>1</sup>

This standard is issued under the fixed designation C212; the number immediately following the designation indicates the year of original adoption or, in the case of revision, the year of last revision. A number in parentheses indicates the year of last reapproval. A superscript epsilon ( $\epsilon$ ) indicates an editorial change since the last revision or reapproval.

*This standard has been approved for use by agencies of the U.S. Department of Defense.*

### 1. Scope\*

1.1 This specification covers structural clay loadbearing facing tile. Structural facing tile are tile designed for use in interior and exterior unplastered walls and partitions of buildings.

1.2 The property requirements of this specification apply at the time of purchase. The use of results from testing of tile extracted from masonry structures for determining conformance or nonconformance to the property requirements (Section 6) of this standard is beyond the scope of this specification.

1.3 Tile covered by this specification are manufactured from clay, shale, or similar naturally occurring substances and subjected to a heat treatment at elevated temperatures (firing). The heat treatment must develop sufficient fired bond between the particulate constituents to provide the strength and durability requirements of this specification. (See *firing* and *fired bond* in Terminology C1232.)

1.4 The text of this specification references notes and footnotes which provide explanatory material. These notes and footnotes (excluding those in tables and figures) shall not be considered as requirements of the specification.

1.5 The values stated in inch-pound units are to be regarded as standard. The values given in parentheses are mathematical conversions to SI units that are provided for information only and are not considered standard.

1.6 *This international standard was developed in accordance with internationally recognized principles on standardization established in the Decision on Principles for the Development of International Standards, Guides and Recommendations issued by the World Trade Organization Technical Barriers to Trade (TBT) Committee.*

### 2. Referenced Documents

2.1 *ASTM Standards:*<sup>2</sup>

[C67 Test Methods for Sampling and Testing Brick and Structural Clay Tile](#)  
[C1232 Terminology for Masonry](#)

### 3. Terminology

3.1 *Definitions*—For definitions relating to structural clay facing tile, refer to Terminology C1232.

<sup>1</sup> This specification is under the jurisdiction of ASTM Committee C15 on Manufactured Masonry Units and is the direct responsibility of Subcommittee C15.02 on Brick and Structural Clay Tile.

Current edition approved Jan. 1, 2020 June 1, 2021. Published January 2020 June 2021. Originally approved in 1946. Last previous edition approved in 2017 2020 as C212–17–20. DOI: 10.1520/C0212-20.10.1520/C0212-21.

<sup>2</sup> For referenced ASTM standards, visit the ASTM website, www.astm.org, or contact ASTM Customer Service at service@astm.org. For *Annual Book of ASTM Standards* volume information, refer to the standard's Document Summary page on the ASTM website.

\*A Summary of Changes section appears at the end of this standard

#### 4. Classification

4.1 Two types of structural clay facing tile are covered, as follows:

4.1.1 *Type FTX*—Smooth-face tile suitable for general use in exposed exterior and interior masonry walls and partitions, and adapted for use where tile low in absorption, easily cleaned, and resistant to staining are required, and where a high degree of mechanical perfection, narrow color range, and minimum variation in face dimensions are desired.

4.1.2 *Type FTS*—Smooth- or rough-texture face tile suitable for general use in exposed exterior and interior masonry walls and partitions and adapted for use where tile of moderate absorption, moderate variation in face dimensions, and medium color range are permitted, and where minor defects in surface finish, including small handling chips, are not objectionable. Two-face tile having one smooth face and one rough-texture face are included in this type.

4.2 Two classes of structural clay facing tile are covered, as follows:

4.2.1 *Standard*—Tile suitable for general use in exterior or interior masonry walls and partitions.

4.2.2 *Special Duty*—Tile suitable for general use in exterior or interior masonry walls and partitions, and designed to have superior resistance to impact and moisture transmission and to support greater lateral and compressive loads than standard tile construction.

#### 5. Ordering Information

5.1 Orders for material under this specification shall include the following information:

5.1.1 *Type*—See 4.1.

5.1.2 *Class*—See 4.2. When class is not specified, the requirements for standard tile shall govern. If special duty tile are desired, the words “special duty” shall be included in the specifications. Special duty tile shall be accepted in lieu of standard tile except where the extra weight is an important factor in the loading of supporting members.

5.1.3 *Texture and Color*—See Section 8. For two-face tile, identify required texture for each face.

5.1.4 *Sizes and Shapes*—Sizes and shapes shall be as specified.

5.1.5 *Number of Faces*—If two-face tile are desired, this shall be stated by the purchaser; otherwise, single-face tile may be furnished.

#### 6. Physical Properties

6.1 *Absorption:*

6.1.1 The tile shall conform to one of the requirements for water absorption of the type specified as prescribed in **Table 1**.

6.1.2 For Type FTS tile for use in masonry not exposed to frost action or in exposed masonry walls with an outside facing of 3 in. (76.2 mm) or more of stone, brick, or other masonry, limitations on absorption shall be waived.

6.2 *Compressive Strength:*

6.2.1 The tile shall conform to the requirements for compressive strength of the class specified as prescribed in **Table 2**.

**TABLE 1 Maximum Water Absorption**

Type	By 24-h Submersion in Cold Water, %		By 1-h Boiling, %	
	Average	Individual	Average	Individual
FTX	7.0	9.0	9.0	11.0
FTS	13.0	16.0	16.0	19.0

**TABLE 2 Compressive Strength Based on Gross Area**

Class	End-Construction Tile		Side-Construction Tile	
	Minimum Average of Five Tests, psi (MPa)	Individual Minimum, psi (MPa)	Minimum Average of Five Tests, psi (MPa)	Individual Minimum, psi (MPa)
Standard	1400 (9.7)	1000 (6.9)	700 (4.8)	500 (3.4)
Special duty	2500 (17.2)	2000 (13.8)	1200 (8.3)	1000 (6.9)

6.2.2 Special duty tile shall be accepted in lieu of standard tile except where the extra weight is an important factor in the loading of supporting members.

## 7. Dimensions and Permissible Variations

7.1 *Tolerances on Dimensions*—The average size of the tile furnished shall approximate closely the size specified in the invitation for bids. The dimensions of individual tile shall not differ from the specified standard dimensions for the type specified by more than the amounts given in **Table 3**. The thickness of a two-face tile shall be either the maximum or minimum thickness of the tile, whichever is farthest from the specified unit dimension.

7.2 *Tolerances on Warpage*—Warpage of face or edges of individual tile from a plane surface or from a straight line, respectively, shall not exceed the amounts shown in **Table 4** for the type specified.

NOTE 1—The thickness of individual two-face tile is affected by the warpage (7.2). ~~The thickness of a two-face tile shall be considered either the maximum or minimum thickness of the tile, whichever is farthest from the standard dimension.~~

## 8. Finish and Appearance

8.1 The body of all tile shall be of clay, shale, fire clay, or mixtures of these materials with or without admixtures, burned to meet the requirements of this specification. The body of all tile shall be free of cracks longer than one fourth of the dimension of the tile in the direction of the crack. The face or faces that will be exposed when in place shall be free of cracks that extend through the thickness of the face shell and free of chips that exceed the limits given in **Table 5**, except that percentages of the shipment are allowed additional chippage which shall not exceed the limits given in **Table 6**. The tile shall be free of other imperfections detracting from the appearance of the finished wall when viewed under diffused lighting at a distance of 10 ft (3.04 m) for Type FTX and at a distance of 15 ft (4.57 m) for Type FTS. <https://standards.iteh.ai/>

8.2 *Plaster Base Finish*—Surfaces of tile for plaster-base finish shall be smooth, scored, combed, or roughened. When smooth, the tile shall be free of glaze and the absorption shall be not less than 5 % . When scored, each groove shall be not less than 1/16 in. (1.6 mm) nor more than 1/4 in. (6.4 mm) in depth and not more than 1 in. (25.4 mm) in width. The area covered by grooves shall not exceed 50 % of the area of the scored faces. When combed, the tile shall be scratched or scarified, prior to burning, by mechanical means which shall make scratches or scarifications on the surface of the tile not less than 1/16 in. (1.6 mm) nor more than 1/8 in. (3.2 mm) in depth, and not more than 1/4 in. apart. When roughened, the die skin on the face of the tile shall be entirely broken by mechanical means, such as wire cutting or wire brushing. (The die skin is visible within the cells of the tile.)

8.3 *Type FTX*—The face or faces of all tile that will be exposed when in place shall have a smooth and unbroken natural die finish. (The die finish is visible within the cells of the tile.) The color range of the finished faces shall conform to an approved sample consisting of not less than five stretcher tile fully representing the range of shade.

**TABLE 3 Tolerances on Dimensions**

Specified Unit Dimension, in. (mm)	Maximum Permissible Variation from Specified Unit Dimension, plus or minus, in. (mm)	
	FTX	FTS
3 (76.2) and under	1/16 (1.6)	3/32 (2.4)
Over 3 to 4 (76.2 to 101.6), incl	3/32 (2.4)	2/16 (3.2)
Over 4 to 6 (101.6 to 152.4), incl	2/16 (3.2)	3/16 (4.8)
Over 6 to 8 (152.4 to 203.2), incl	5/32 (4.0)	4/16 (6.4)
Over 8 to 12 (203.2 to 304.8), incl	7/32 (5.6)	5/16 (7.9)
Over 12 to 16 (304.8 to 406.4), incl	9/32 (7.1)	6/16 (9.5)

TABLE 4 Tolerances on Warpage

Maximum Face Dimensions (Height or Length), in. (mm)	Maximum Permissible Warpage, in. (mm)	
	Type FTX	Type FTS
8 (203.2) and under	$\frac{3}{32}$ (2.4)	$\frac{4}{32}$ (3.2)
Over 8 to 12 (203.2 to 304.8), incl	$\frac{4}{32}$ (3.2)	$\frac{6}{32}$ (4.8)
Over 12 to 16 (304.8 to 406.4), incl	$\frac{6}{32}$ (4.8)	$\frac{8}{32}$ (6.4)

TABLE 5 Maximum Permissible Extent of Chippage From the Edges and Corners of Finished Face or Faces Into the Surfaces

Type	Chippage in inches (millimetres) in from	
	Edge	Corner
FTX	$\frac{1}{4}$ (3.2)	$\frac{1}{4}$ (6.4)
FTS (smooth) <sup>A</sup>	$\frac{1}{4}$ (6.4)	$\frac{3}{8}$ (9.5)
FTS (rough) <sup>B</sup>	$\frac{5}{16}$ (7.9)	$\frac{1}{2}$ (12.7)

<sup>A</sup>Smooth texture is the unbroken natural die finish.

<sup>B</sup>Rough texture is the finish produced when the face is sanded, combed, scratched, or scarified, or the die skin on the face is entirely broken by mechanical means, such as wire cutting or wire brushing.

TABLE 6 Percentages of Shipment Allowed Chippage Over Maximum Permissible in Table 5

Type	Percentage Allowable	Chippage in inches (millimetres) in from	
		Edge	Corner
FTX	5	$\frac{1}{4}$ (6.4)	$\frac{3}{8}$ (9.5)
FTS (smooth)	10	$\frac{5}{16}$ (7.9)	$\frac{1}{2}$ (12.7)
FTS (rough)	15	$\frac{7}{16}$ (11.1)	$\frac{3}{4}$ (19.1)

iTech Standards  
(<https://standards.iteh.ai>)  
Document Preview

8.4 *Type FTS*—The texture of the finished surface that will be exposed when in place shall conform to an approved sample consisting of not less than five stretcher tile, each representing the texture desired. The approximate color range shall be indicated by an approved sample consisting of not less than five stretcher tile.

NOTE 2—Facing tile are not ordinarily available in uniform (straight range) colors. Samples submitted for approval should include the extremes of the color ranges that will be furnished, unless full burning range (kiln run) is acceptable.

## 9. Coring

9.1 Requirements as to coring shall apply to multicored tile only. Multicored tile (Fig. 1) shall contain hollow spaces (cores) which are enclosed within the perimeter of the exterior shells and have a cross-sectional area of not more than  $1\frac{1}{2}$  in.<sup>2</sup> (9.7 cm<sup>2</sup>).

9.2 The type of coring is optional with each manufacturer. The distance from the perimeter of the core to the face of the tile shall be not less than  $\frac{3}{4}$  in. (19.1 mm) except in tile that are designed to be split for fractional lengths where the maximum distance from the face of the tile to the perimeter of the kerfing cores shall be not less than  $\frac{1}{2}$  in. (12.7 mm).

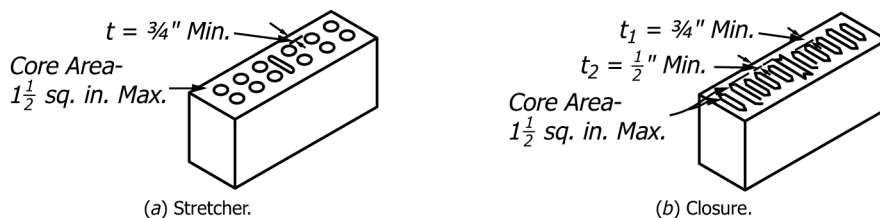

FIG. 1 Multicored Tile (4-in. Thickness)

10. Size and Number of Cells

10.1 Requirements as to number of cells in direction of wall thickness and as to shell and web thickness shall apply to hollow tile only. Hollow tile (Fig. 2) shall contain hollow spaces (cells) which are enclosed within the perimeter of the exterior shells and have a minimum dimension greater than 1/2 in. (12.7 mm) and a cross-sectional area greater than 1 1/2 in.<sup>2</sup> (9.7 cm<sup>2</sup>). End-construction tile are designed to be placed in the wall with the axes of the cells vertical. Side-construction tile are designed to be placed in the wall with the axes of the cells horizontal. Where end-construction tile are used on the side they shall conform to the requirements of side-construction tile and vice versa.

10.2 Hollow tile shall conform to the following requirements as to number of cells in the direction of wall thickness:

Nominal Horizontal Thickness of Tile as Laid in Wall, in. (mm)	Minimum Number of Cells in Direction of Wall Thickness
4 (101.6)	1
6 (152.4)	2
8 (203.2)	2
10 (254.0)	3
12 (304.8)	3

The following tile shall be considered as having one additional cell in the direction of wall thickness:

10.2.1 Standard double-shell tile, provided the combined width of the voids between exterior and interior side shells on both sides of the tile is not less than 1/2 in. (12.7 mm) and the combined thickness of the short webs between inner and outer shells is not greater than that of the long transverse webs holding the inner shells.

10.2.2 All special duty double-shell tile, also special duty solid and cored-shell tile having face shells at least 1 1/2 in. (38.1 mm) thick on both sides of the tile.

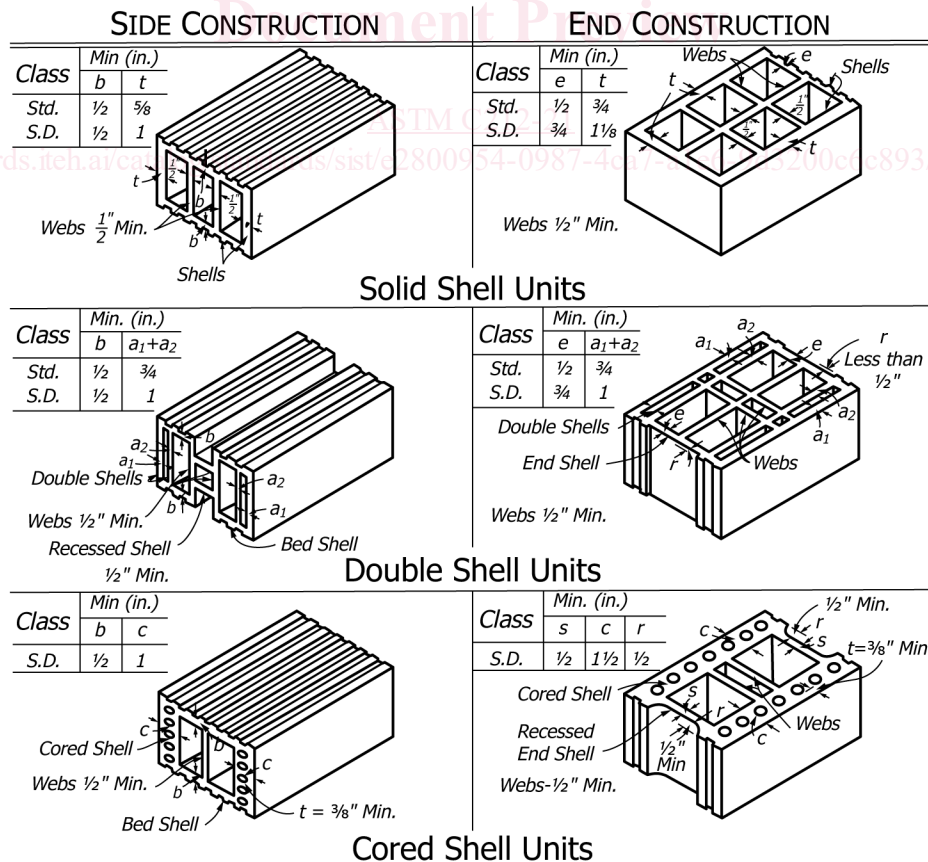

FIG. 2 Hollow Tile (8-in. Thickness)