

INTERNATIONAL STANDARD

ISO 4903

Second edition
1989-10-01

Information technology — Data communication — 15-pole DTE/DCE interface connector and contact number assignments

iTeh STANDARD PREVIEW
*Technologies de l'information — Communication de données — Connecteur
d'interface ETTD/ETCD à 15 pôles, et affectation des numéros de contact*
(standards.iteh.ai)

[ISO 4903:1989](#)

<https://standards.iteh.ai/catalog/standards/sist/45e2ecf5-9d65-4725-a90c-3f0aabd12846/iso-4903-1989>



Reference number
ISO 4903 : 1989 (E)

Foreword

ISO (the International Organization for Standardization) is a worldwide federation of national standards bodies (ISO member bodies). The work of preparing International Standards is normally carried out through ISO technical committees. Each member body interested in a subject for which a technical committee has been established has the right to be represented on that committee. International organizations, governmental and non-governmental, in liaison with ISO, also take part in the work. ISO collaborates closely with the International Electrotechnical Commission (IEC) on all matters of electrotechnical standardization.

Draft International Standards adopted by the technical committees are circulated to the member bodies for approval before their acceptance as International Standards by the ISO Council. They are approved in accordance with ISO procedures requiring at least 75 % approval by the member bodies voting.

International Standard ISO 4903 was prepared by Technical Committee ISO/TC 97, *Information processing systems*.

This second edition cancels and replaces the first edition (ISO 4903 : 1980), of which it constitutes a minor revision; certain terms have been aligned with the terms and definitions used by IEC.

© ISO 1989

All rights reserved. No part of this publication may be reproduced or utilized in any form or by any means, electronic or mechanical, including photocopying and microfilm, without permission in writing from the publisher.

International Organization for Standardization
Case postale 56 • CH-1211 Genève 20 • Switzerland

Printed in Switzerland

Information technology — Data communication — 15-pole DTE/DCE interface connector and contact number assignments

1 Scope

This International Standard specifies the 15-pole connector and the assignment of contact numbers at the interface between data terminal equipment (DTE) and data circuit-terminating equipment (DCE) where CCITT¹⁾ Recommendations X.24, X.26, and X.27 are applicable.

International Standard ISO/IEC 4903 additionally provides the dimensions of the connector housing, as well as the recommended means of providing a locking device (latching block) and connector shielding.

2 Normative references

The following standards contain provisions which, through reference in this text, constitute provisions of this International Standard. At the time of publication, the editions indicated were valid. All standards are subject to revision, and parties to agreements based on this International Standard are encouraged to investigate the possibility of applying the most recent editions of the standards indicated below. Members of IEC and ISO maintain registers of currently valid International Standards.

ISO 261 : 1973, *ISO general purpose metric screw threads — General plan*.

ISO 2110 : 1989, *Information technology — Data communication — 25-pole DTE/DCE interface connector and contact number assignments*.

CCITT Recommendation V.28 : 1989, *Electrical characteristics for unbalanced double-current interchange circuits*.

CCITT Recommendation X.20 : 1989, *Interface between data terminal equipment (DTE) and data circuit-terminating equipment (DCE) for start-stop transmission services on public data networks*.

CCITT Recommendation X.21 : 1989, *Interface between data terminal equipment (DTE) and data circuit-terminating equipment (DCE) for synchronous operation on public data networks*.

CCITT Recommendation X.22 : 1989, *Multiplex DTE/DCE interface for user classes 3-6*.

CCITT Recommendation X.24 : 1989, *List of definitions for interchange circuits between data terminal equipment (DTE) and data circuit-terminating equipment (DCE) on public data network*.

CCITT Recommendation X.26 (or V.10) : 1989, *Electrical characteristics for unbalanced double-current interchange circuits for general use with integrated circuit equipment in the field of data communications*.

CCITT Recommendation X.27 (or V.11) : 1989, *Electrical characteristics for balanced double-current interchange circuits for general use with integrated circuit equipment in the field of data communications*.

IEC Publication 50(581) : 1978, *International Electrotechnical Vocabulary — Chapter 581 : Electromechanical components for electronic equipment*.

IEC Publication 807-2 : 1985, *Rectangular connectors for frequencies below 3 MHz — Part 2: Detail specification for a range of connectors with round contacts — Fixed solder contact types*.

3 Definitions

The following definitions have been taken from IEC Publication 50(581) : 1978.

3.1 cable adaptor: A part of a connector or an accessory consisting of a rigid housing for attachment to the connector body. It may incorporate provision for a cable clamp or seal for terminating screens and provide shielding from electrical interference. It may be straight or angled.

3.2 connector housing: A part of a connector into which the insert and contacts are assembled.

3.3 contact arrangement: The number, spacing and configuration of contacts in a component.

1) International Telegraph and Telephone Consultative Committee.

3.4 female contact: A contact intended to make electrical engagement on its inner surface and which will accept entry of a male contact.

3.5 intermateable connectors: Two connectors are intermateable when they are capable of being connected electrically and mechanically but without regard to their performance and intermountability.

3.6 locking device: A feature incorporated in certain components to provide mechanical retention of their mating part.

3.7 male contact: A contact intended to make electrical engagement on its outer surface and which will enter a female contact.

3.8 (n-pole-)connector: A component which terminates conductors for the purpose of providing connection and disconnection to a suitable mating component.

4 Connector

Figures 1 to 5 illustrate the 15-pole interface connector. Only those dimensions that are essential to mating are shown. Figure 1 illustrates the DTE connector which has 15 male contacts in a connector housing. Figure 2 illustrates the DCE connector which has 15 female contacts in a connector housing. The connector housing on the DCE connector is dimensioned to fit inside the connector housing on the DTE connector (see figures 1 and 2). Contact numbering is specified in figures 1 and 2. Figure 3 illustrates the dimensions for the contact spacing. Figures 4 and 5 illustrate the dimensions for the male and female contacts respectively.

The DCE connector shall be equipped with a locking device consisting of two latching blocks as specified in figure 2. Due to the fact that the latching blocks have threaded holes which can act as nuts, the DTE connector may be equipped either with lever devices for latching to the latching blocks on the DCE connector or with screws that fit into the threaded holes in the latching blocks.

The thread of the latching blocks shall be M3 as specified in figure 2.

Sufficient connector dimensions are provided in this International Standard to ensure intermateable connectors. They are consistent with the detailed connector specification in IEC Publication 807-2.

In annex A, diagrams for finger clearance areas are given to provide guidance for equipment designers. Figure A.1 shows the maximum DTE connector outline including all means for latching to the latching blocks. Figure A.2 shows the minimum DCE connector spacing when multiple interface arrangements are used.

5 Assignment of contact numbers

The assignment of contact numbers for the interchange circuits specified in CCITT Recommendations X.20, X.21 and X.22 is given in table 1 for implementations using X.26 and X.27 electrical characteristics. Additionally, contact 1 is reserved for connection of the shield of shielded interconnecting cable. Table 2 gives a list of interchange circuits and their description. Their provision and use shall be in conformity with the corresponding CCITT DCE Recommendations.

6 Connector shielding

Connector shielding is optional. If it is used, for example due to national regulations, etc., it shall be accomplished by the use of metallic connector housings on both the DTE connector and the DCE connector.

7 Interconnecting configurations for mixed use of X.26, X.26 and V.28 electrical characteristics

Considerations for the interworking of equipment implementing X.26 on one side of the interface with equipment implementing X.27 on the other side of the interface are given in annex A.2 of CCITT Recommendations X.26 and X.27. In addition, the definition of the category 1 and 2 receiver configurations is provided in V.10.

Guidance concerning possible interconnecting configurations applicable to the X.20 and X.21 interfaces is provided in annex B.

Guidance concerning the necessary adaptation when there is a need for X.20 DCE implementing X.26 characteristics to interwork with X.20 DTE implementing V.28 characteristics is given in annex C. Any adapters required to accomplish the interworking with equipment meeting the V.28 requirements shall be provided with equipment meeting the requirements of this International Standard, i.e., the X.20/X.26 DCE. No revisions or modifications shall be required in the equipment using V.28 electrical characteristics.

Table 1 — Assignment of contact numbers for interface CCITT Recommendations X.20, X.21, and X.22

Contact number ⁶⁾	Interchange circuit assignment				
	X.20 ²⁾		X.21 ³⁾		X.22
	X.26	X.27 ⁵⁾	X.26 ^{4), 5)}	X.27 ⁵⁾	X.27 ⁵⁾
1	1) ¹⁾	1) ¹⁾	1) ¹⁾	1) ¹⁾	1) ¹⁾
2	T	T(A)	T	T(A)	T(A)
3	—	—	C	C(A)	C(A)
4	R	R(A)	R(A)	R(A)	R(A)
5	—	—	I(A)	I(A)	I(A)
6	—	—	S(A)	S(A)	S(A)
7	—	—	X/B(A) ⁷⁾	X/B(A) ⁷⁾	F(A)
8	G	G	G	G	G
9	Ga	T(B)	Ga	T(B)	T(B)
10	—	—	Ga	C(B)	C(B)
11	Gb	R(B)	R(B)	R(B)	R(B)
12	—	—	I(B)	I(B)	I(B)
13	—	—	S(B)	S(B)	S(B)
14	—	—	X/B(B) ⁷⁾	X/B(B) ⁷⁾	F(B)
15	Reserved for future international use				

NOTES

1 Contact 1 is assigned for connecting the shields between tandem sections of shielded interface cable. The shield may be connected either to protective ground or to signal ground at either the DTE or DCE or both in accordance with national regulations.

Signal ground may be further connected to protective ground in accordance with national safety regulations. Caution should be exercised to avoid establishment of ground loops carrying high currents.

2 DTEs may employ either X.26 or X.27 electrical characteristics to operate with DCEs using X.26 electrical characteristics in accordance with X.20.

3 DTEs may employ either X.26 or X.27 electrical characteristics to operate with DCEs using X.27 electrical characteristics in accordance with X.21 for data signalling rates of 9,6 kbit/s and below. Only X.27 applies above 9,6 kbit/s.

4 The assignment of contact numbers has been chosen considering interworking between X.26 DTE and X.27 DCE using the considerations given in annex 2 of Recommendations X.26 and X.27.

5 Where balanced circuits are concerned, the associated pairs are designated "A" and "B" in X.27.

6 The assignment of contact numbers has been aligned to specify pairing and connection to multipaired interconnecting cable. Respective paired contacts are 2 and 9, 3 and 10, ..., 8 and 15.

7 Circuit X is used if the DTE has to provide signal element timing.

Table 2 — List of interchange circuits

Circuit designation	Description
G	Signal ground or common return
Ga	DTE common return
Gb	DCE common return
T	Transmit
R	Receive
C	Control
I	Indication
S	Signal element timing
B	Byte timing
F	Frame start identification
X	DTE transmit signal element timing

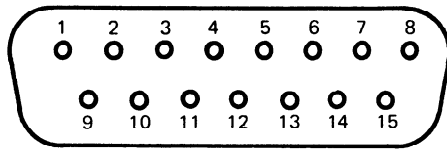

DTE contact arrangement viewed from connector front (DCE side)

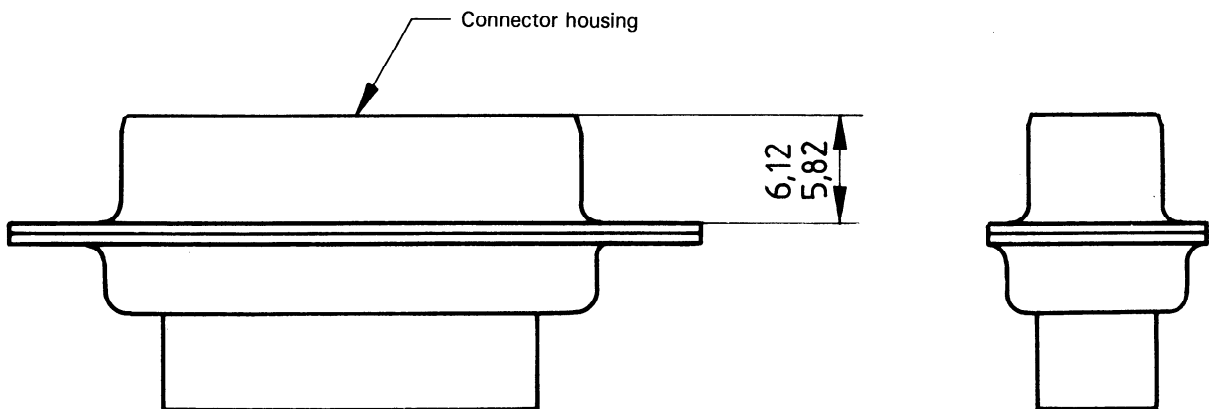
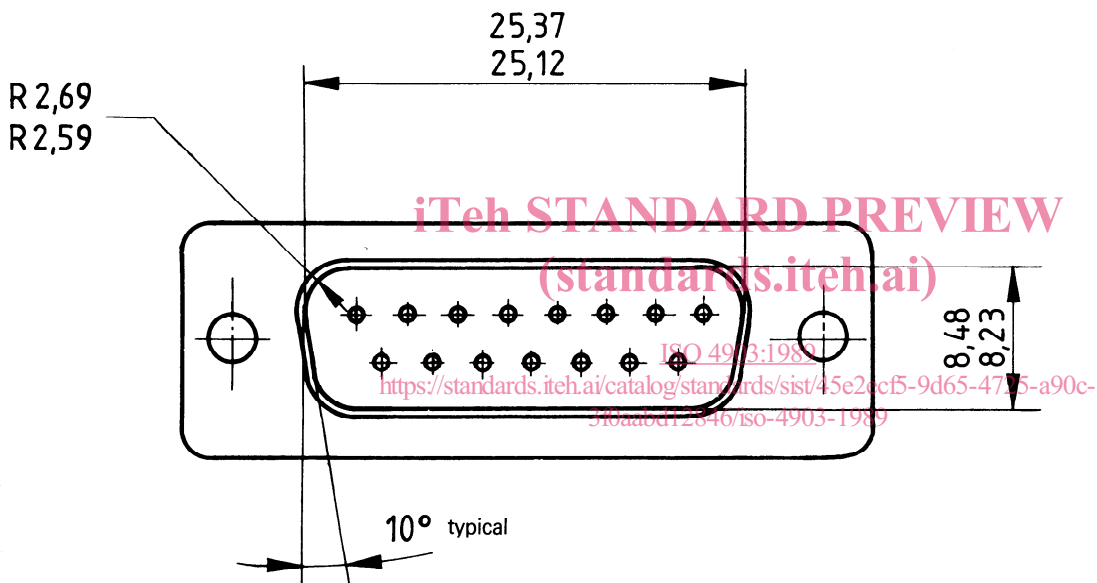
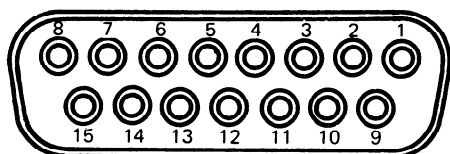
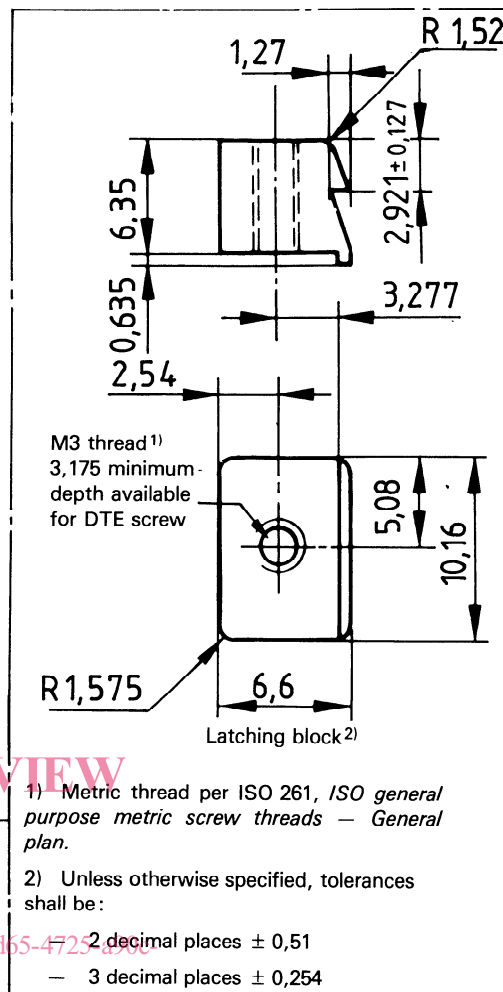

Figure 1 – DTE connector

Dimensions in millimetres



DCE contact arrangement viewed from connector front (DTE side)



1) Metric thread per ISO 261, ISO general purpose metric screw threads – General plan.

2) Unless otherwise specified, tolerances shall be:

- 2 decimal places ± 0,51
- 3 decimal places ± 0,254

iTeh STANDARD PREVIEW
(standards.iteh.ai)

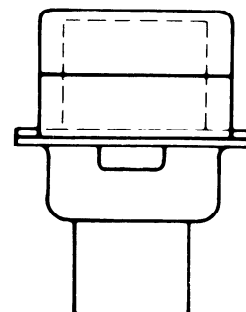
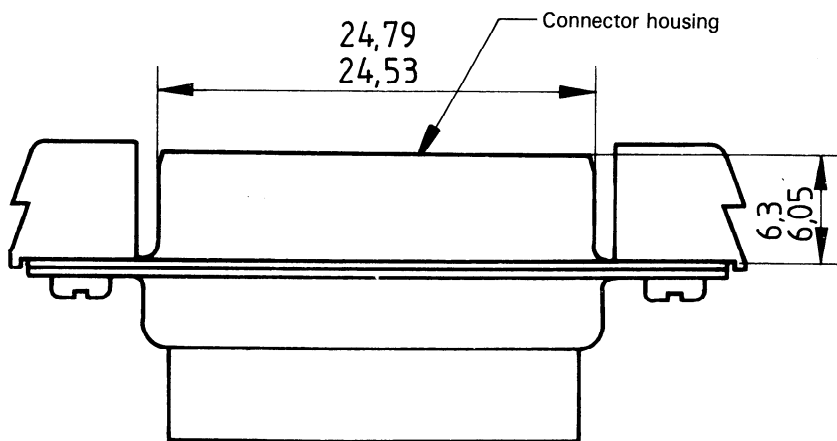
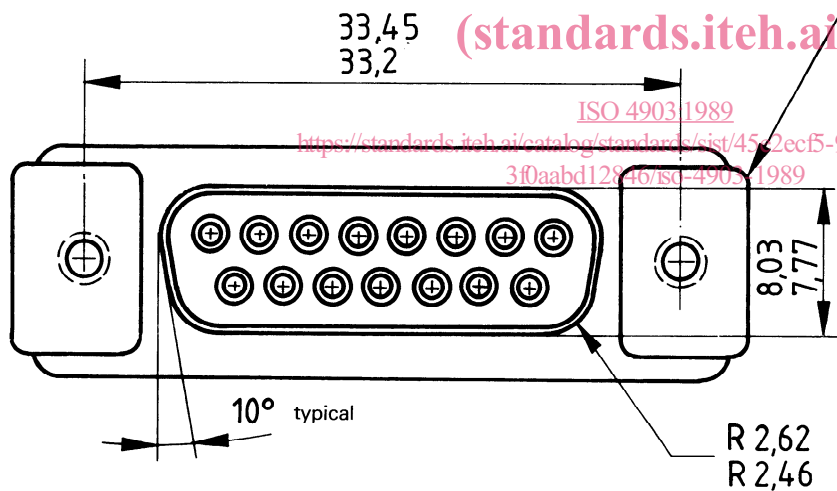

Figure 2 – DCE connector

Dimensions in millimetres

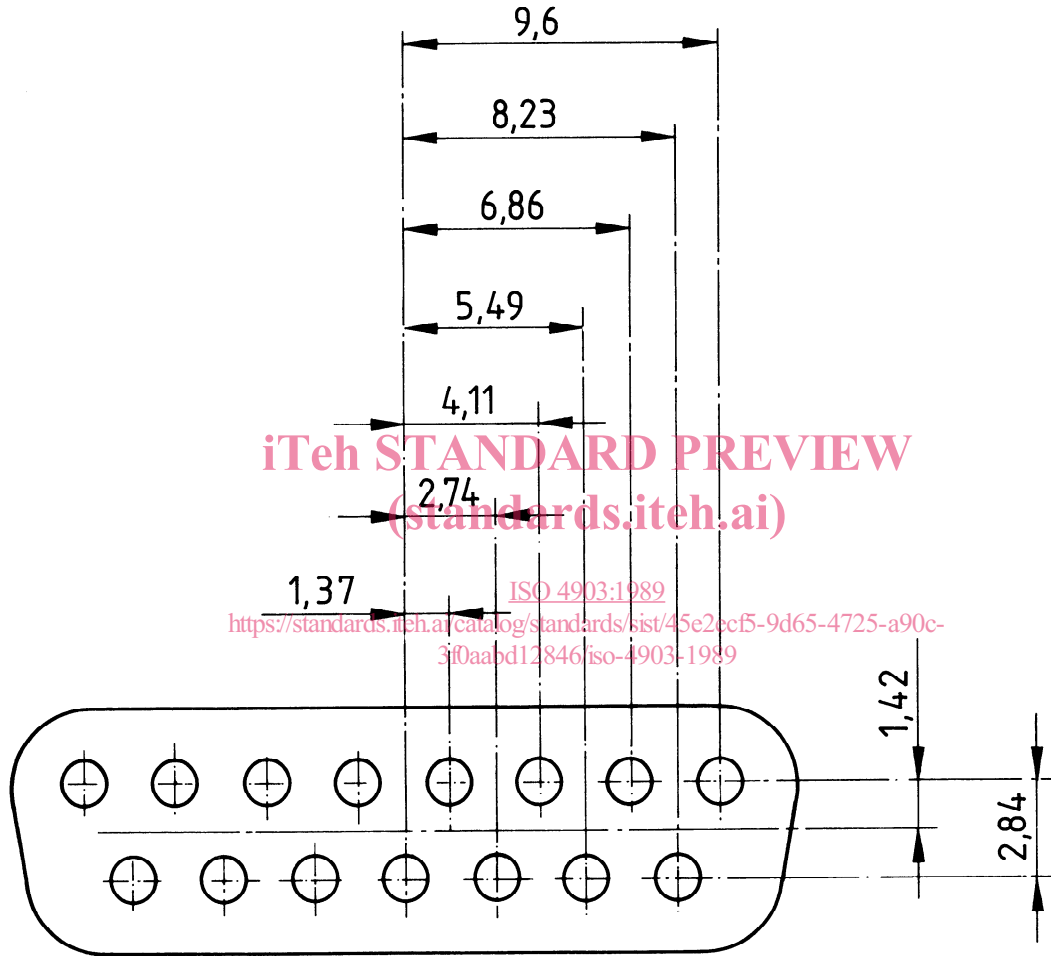

Figure 3 — Contact spacing dimensions

Dimensions in millimetres

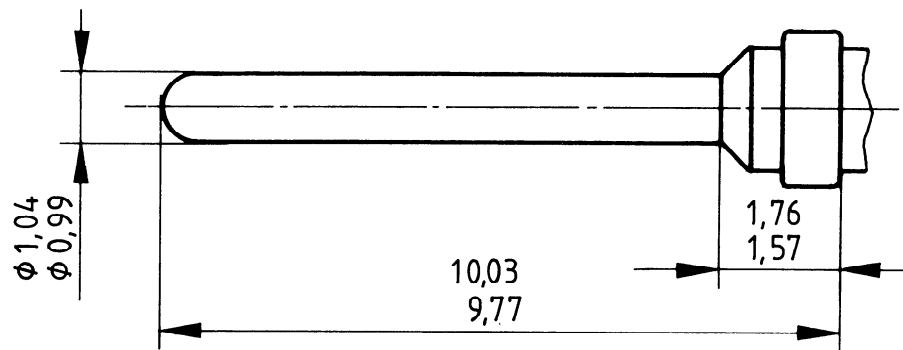
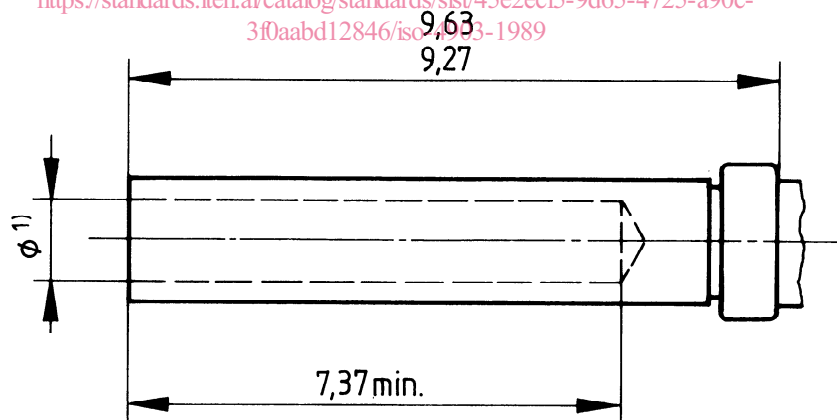

Figure 4 — Male contact

iTeh STANDARD PREVIEW
(standards.iteh.ai)

ISO 4903:1989

<https://standards.iteh.ai/catalog/standards/sist/45e2ecf5-9d65-4725-a90c-3f0aabd12846/iso-4903-1989>



1) When the male contact is mated with the female contact, sufficient force should be applied by the female contact to ensure proper electrical contact.

Figure 5 — Female contact

Annex A
(informative)

Diagrams for finger clearance

This annex provides guidance on finger clearance for equipment designers.

Figure A.1 shows the maximum DTE connector outline.

Figure A.2 shows the minimum recommended spacing between multiple DCE connectors, taking into account the various locking devices (levers, screws) of DTE connectors.

Dimensions in millimetres

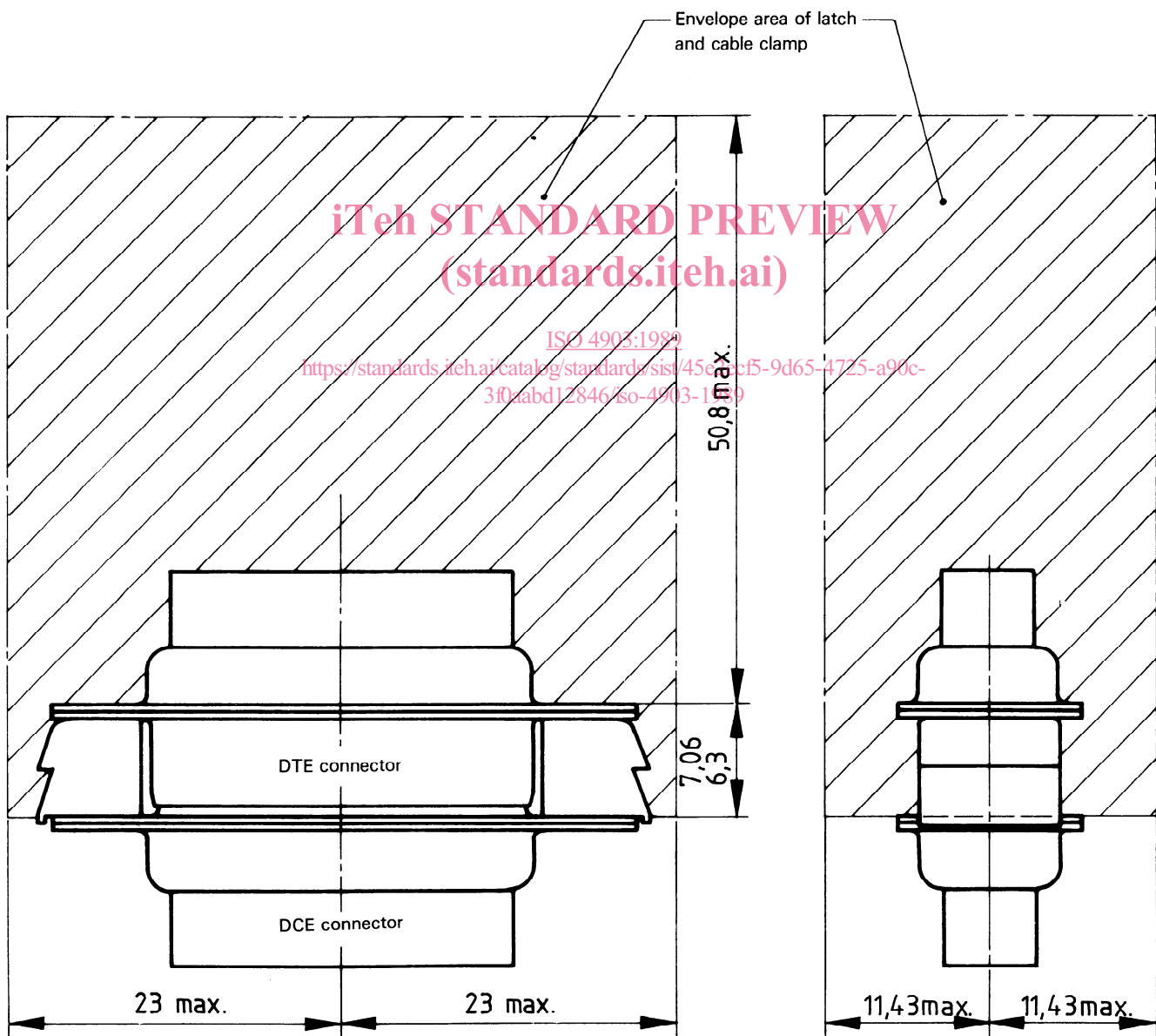

Figure A.1 – Maximum DTE connector outline

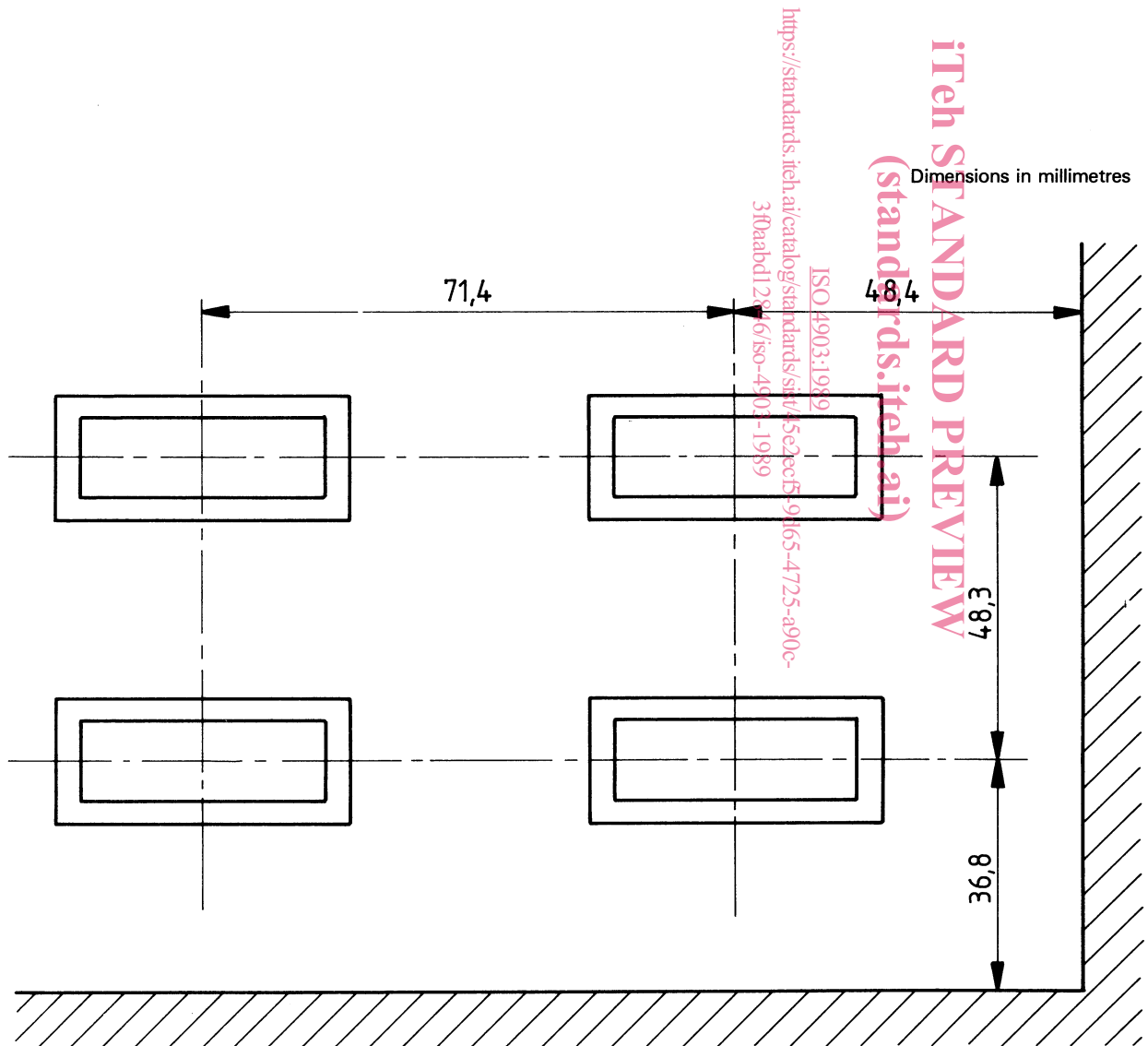

Figure A.2 – Minimum DCE connector spacing